



AD-200 Phase 7

Parts Manual

(with Tilt Options)

American Dryer Corporation
88 Currant Road
Fall River MA 02720-4781
Telephone: (508) 678-9000 / Fax: (508) 678-9447
E-mail: techsupport@amdry.com

Retain This Manual In A Safe Place For Future Reference

American Dryer Corporation products embody advanced concepts in engineering, design, and safety. If this product is properly maintained, it will provide many years of safe, efficient, and trouble-free operation.

ONLY qualified technicians should service this equipment.

OBSERVE ALL SAFETY PRECAUTIONS displayed on the equipment or specified in the installation/operator's manual included with the dryer.

The following “**FOR YOUR SAFETY**” caution **must be** posted near the dryer in a prominent location.

FOR YOUR SAFETY

Do not store or use gasoline or other flammable vapors or liquids in the vicinity of this or any other appliance.

POUR VOTRE SÉCURITÉ

Ne pas entreposer ni utiliser d'essence ni d'autres vapeurs ou liquides inflammables dans le voisinage de cet appareil ou de tout autre appareil.

We have tried to make this manual as complete as possible and hope you will find it useful. **ADC** reserves the right to make changes from time to time, without notice or obligation, in prices, specifications, colors, and material, and to change or discontinue models.

Important

For your convenience, log the following information:

DATE OF PURCHASE _____ **MODEL NO.** AD-200 Tilt

DISTRIBUTOR'S NAME _____

Serial Number(s) _____

Replacement parts can be obtained from your distributor or the **ADC** factory. When ordering replacement parts from the factory, you can FAX your order to **ADC** at (508) 678-9447 or telephone your orders directly to the **ADC** Parts Department at (508) 678-9000. Please specify the dryer **model number** and **serial number** in addition to the **description** and **part number**, so that your order is processed accurately and promptly.

The illustrations on the following pages may not depict your particular dryer exactly. The illustrations are a composite from the various dryer models. Be sure to check descriptions of the parts thoroughly before ordering.

“IMPORTANT NOTE TO PURCHASER”

Information must be obtained from your local gas supplier on the instructions to be followed if the user smells gas. These instructions must be posted in a prominent location near the dryer.

Table of Contents

Front Panel Assembly	
Automatic Door	
<i>1-Way Forward Tilt</i>	4, 5
Front Panel Assembly	
Automatic Door	
<i>2-Way Tilt or Rear Tilt ONLY</i>	6, 7
Front Panel Assembly	
Manual Door	
<i>1-Way Forward Tilt</i>	8, 9
Front Panel Assembly	
Manual Door	
<i>2-Way Tilt or Rear Tilt ONLY</i>	10, 11
Rear Panel Assembly	
<i>Forward Tilt ONLY</i>	12
Rear Panel Assembly	
<i>1 Door/2-Way Tilt</i>	13
Rear Panel Assembly	
Automatic Door	
<i>Rear Tilt ONLY</i>	14, 15
Rear Panel Assembly	
Automatic Door	
<i>2-Way Tilt</i>	16, 17
Rear Panel Assembly	
Manual Door	
<i>Rear Tilt ONLY</i>	18, 19
Rear Panel Assembly	
Manual Door	
<i>2-Way Tilt</i>	20, 21
Side Panel Assemblies	22
Left Control Door Assembly	
For 1 Door or 2 Door Models	23
Front Control Door Assembly	24, 25
Left Load Door Assembly	
Automatic Door	26, 27

Right Load Door Assembly	
Automatic Door	28, 29
Left Load Door Assembly	
Manual Door	30, 31
Right Load Door Assembly	
Manual Door	32, 33
Right Rear Control Door Assembly	
2 Door Models ONLY	34, 35
Pneumatic Assembly	
Automatic Door	36
Magnetic Door Switch Assembly	37
Left Hand Electrical Control Panel Assembly	
<i>For Models Mfd. with Thermal-Magnetic Protection ONLY</i>	38, 39
Right Hand Electrical Control Panel	40, 41
Base Main Electrical Junction Box Assembly	
<i>For Models Mfd. with Thermal-Magnetic Protection ONLY</i>	42, 43
Tumbler Drive Shaft Assembly	44, 45
Idler Shaft and Basket Assembly	46
Tumbler Retaining Wheel Assembly	47
Lint Drawer/Basket Assembly	48
Temperature Sensor Bracket Assembly	49
Tilt Fan Motor Assembly	
<i>For Gas Models ONLY</i>	50, 51
Tilt Fan Motor Assembly	
<i>For Steam Models ONLY</i>	52, 53
Drive Motor Assembly	54
Air Jet Assembly	55
Gas Burner Assembly	56, 57
Sail Switch Assembly	58
Direct Spark Ignition (DSI) Module Assembly	59
Tilt Gas Piping Assembly	60, 61
Steam Coil Assembly	62, 63
Steam Piping Assembly	
<i>1-Way Tilt</i>	64, 65, 66
Tilt Switch Assembly	67
Steam Piping Assembly	
<i>2-Way Tilt</i>	68, 69, 70

Tilt Piston Assembly	
<i>1-Way Tilt</i>	71
Tilt Piston Assembly	
<i>2-Way Tilt</i>	72
Sprinkler Temperature Probe Junction Box Assembly	86
Pneumatic Assembly	
For 1 Automatic Door	73
Pneumatic Assembly	
For 2 Automatic Doors	74, 75
Pneumatic Plate Assembly	
<i>1-Way Tilt</i>	76, 77
Pneumatic Panel Assembly	
<i>2-Way Tilt</i>	78, 79
Optional Sprinkler Assembly	80, 81, 82
Pneumatic Assembly For Sprinkler Option	83
Sprinkler Control Panel	84, 85
End of Cycle Light Assembly	87
Guard Panel Assemblies	
<i>Forward Tilt</i>	88
Guard Panel Assemblies	
<i>2-Way Tilt</i>	89, 90
Base Panel Assemblies	
<i>1-Way Tilt</i>	91
Base Panel Assemblies	
<i>2-Way Tilt</i>	92
Selector Switch, Nameplate, and Mounting Base Chart	93
Right Rear/Front Control Panel	94
Right Hand Electrical Component Chart	95

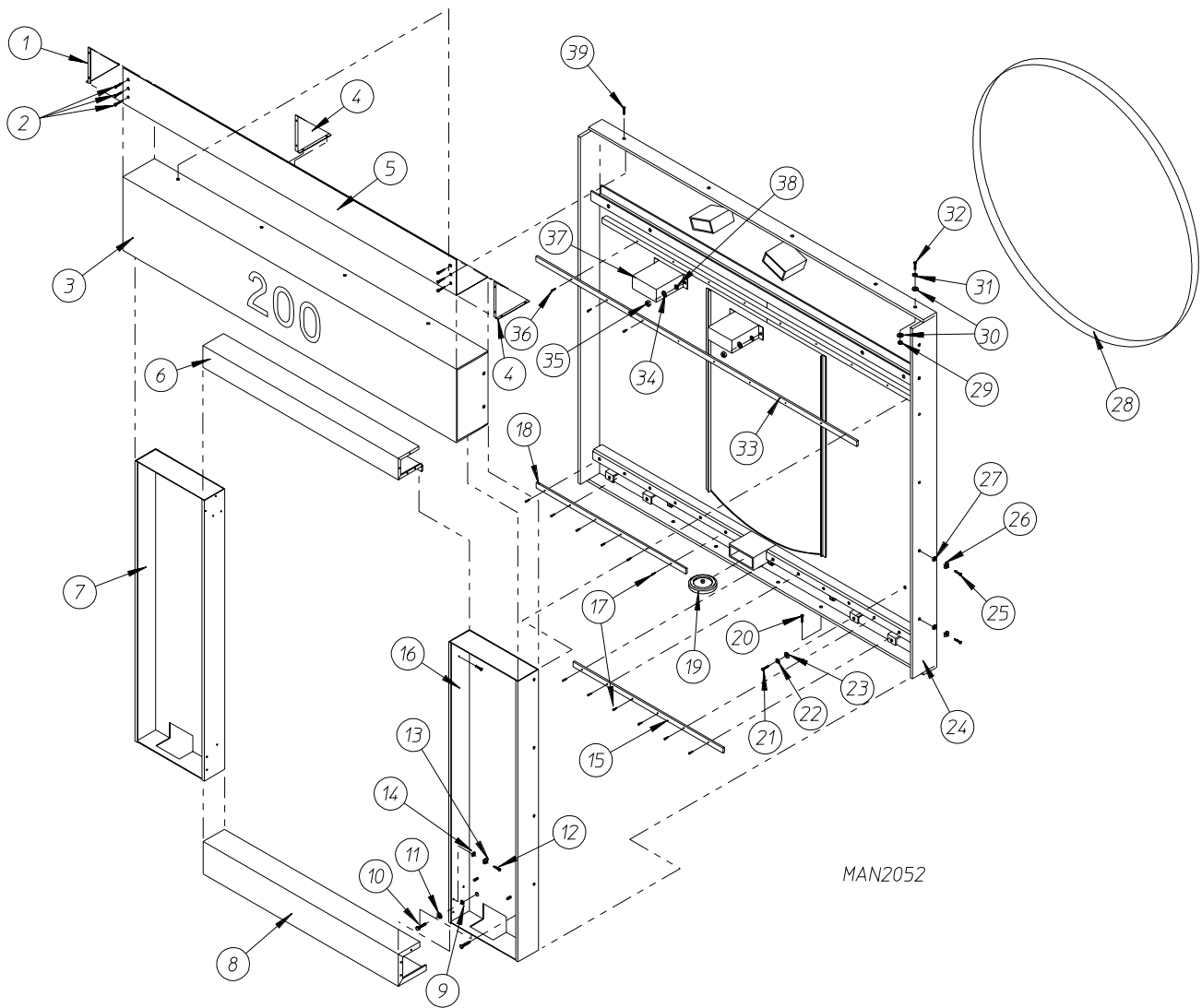

AUTOMATIC DOOR**1-Way Forward Tilt**

<u>Illus. No.</u>	<u>Part No.</u>	<u>Qty.</u>	<u>Description</u>
1	332680	1	Left Gusset (for gas models Only)
2	150522	15	1/4-20 x 1/2" Hex Washer TEK Screw (for gas models Only)
3*	821241	1	Upper Guard
4	332681	2	Right Gusset (for gas models Only)
5*	332679	1	Top Front Panel (for gas models Only)
6*	821239	1	Middle Guard
7*	881114	1	Left Control Door Cabinet
8*	821285	1	Bottom Guard
9	153001	8	5/16" Flat Washer
10	150501	8	5/16-18 x 3/4" Hex Head Machine Bolt
11	153002	8	5/16" Lock Washer
12	150510	12	1/4-20 x 3/4" Hex Head Machine Bolt
13	153007	12	1/4" Lock Washer
14	153018	12	1/4" Flat Washer
15	170364	1	Bottom Door Track
16*	881115	1	Right Control Door Cabinet
17	154312	14	#10-32 x 3/4" Socket Head Cap Screw
18	170364	1	Bottom Door Track
19	-----	-	Tumbler Retaining Wheel (refer to Tumbler Retaining Wheel Assembly on page 47)
20	150523	5	1/4-20 x 3/4" Hex Washer Machine Bolt
21	150617	8	3/8-16 x 1" Hex Head Bolt
22	153005	8	3/8" Lock Washer
23	153004	8	3/8" Flat Washer
24*	881109	1	Front Panel Assembly
25	150501	12	5/16-18 x 3/4" Hex Head Machine Bolt
26	153002	12	5/16" Lock Washer
27	153001	12	5/16" Flat Washer
28	115998	180	Tumbler Ring Felt (sold by the inch)
29	152011	4	1/2-13 Hex Nut
30	153050	8	1/2" x 1-1/16" Flat Washer
31	153026	4	1/2" Lock Washer
32	150605	4	1/2-13 x 1-1/2" Hex Head Bolt
33	170365	1	Upper Door Track
34	153007	12	1/4" Lock Washer
35	152002	12	1/4-20 Hex Nut
36	154312	15	#10-32 x 3/4" Socket Head Cap Screw
37*	821244	2	Tumbler Retaining Wheel Cover
38	153018	12	1/4" Flat Washer
39	150523	5	1/4-20 x 3/4" Hex Washer Machine Bolt

* Specify color when ordering.

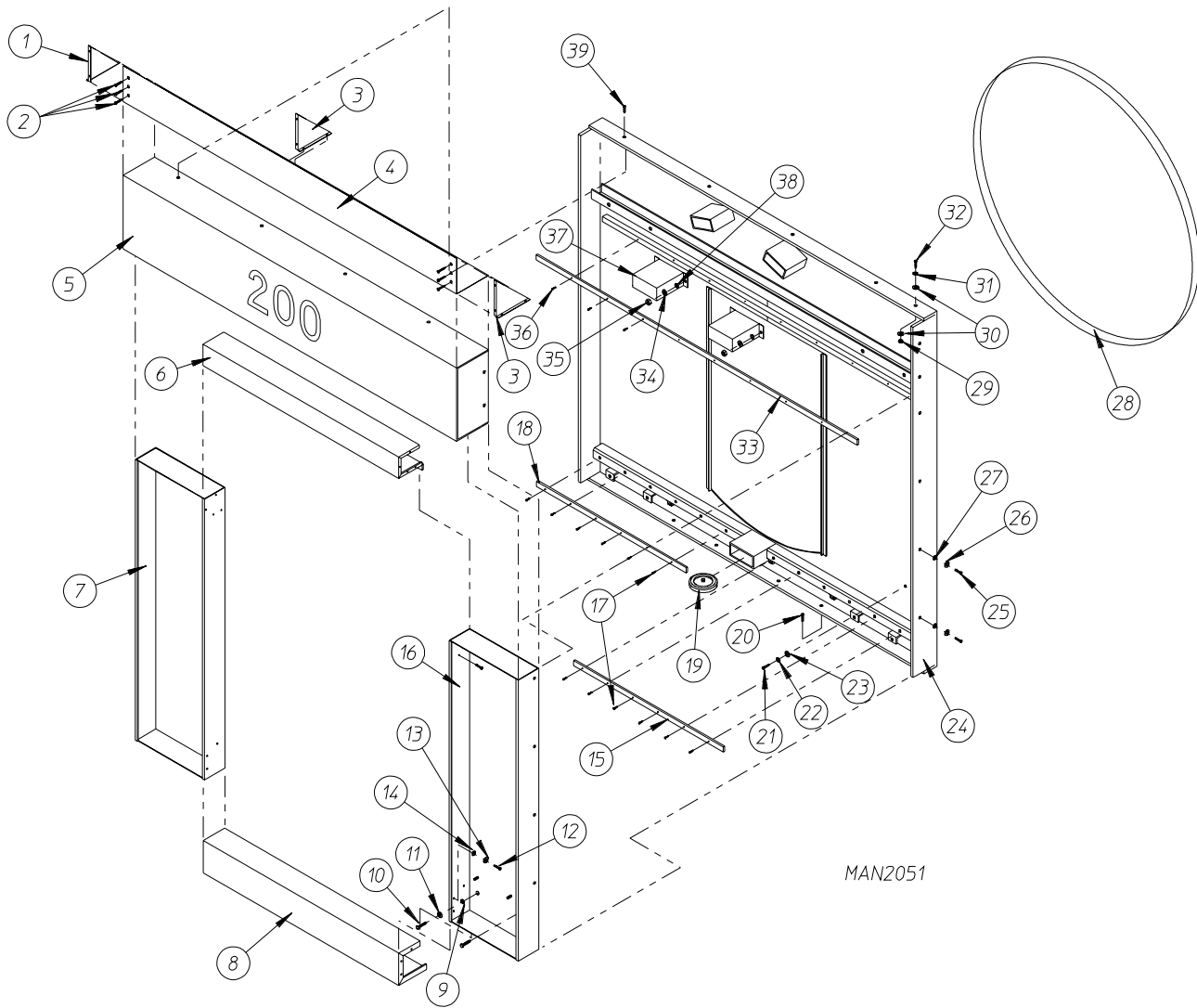

MAN2051

AUTOMATIC DOOR**2-Way Tilt or Rear Tilt ONLY**

<u>Illus. No.</u>	<u>Part No.</u>	<u>Qty.</u>	<u>Description</u>
1	332680	1	Left Gusset (for gas models Only)
2	150522	15	1/4-20 x 1/2" Hex Washer TEK Screw (for gas models Only)
3	332681	2	Right Gusset (for gas models Only)
4*	332679	1	Top Front Panel (for gas models Only)
5*	821241	1	Upper Guard
6*	821239	1	Middle Guard
7*	881117	1	Left Control Cabinet
8*	821285	1	Bottom Guard
9	153001	8	5/16" Flat Washer
10	150501	8	5/16-18 x 3/4" Hex Head Machine Bolt
11	153002	8	5/16" Lock Washer
12	150510	12	1/4-20 x 3/4" Hex Head Machine Bolt
13	153007	12	1/4" Lock Washer
14	153018	12	1/4" Flat Washer
15	170364	1	Bottom Door Track
16*	881116	1	Right Control Cabinet
17	154312	14	#10-32 x 3/4" Socket Head Cap Screw
18	170364	1	Bottom Door Track
19	-----	-	Tumbler Retaining Wheel (refer to Tumbler Retaining Wheel Assembly on page 47)
20	150523	5	1/4-20 x 3/4" Hex Washer Machine Bolt
21	150617	8	3/8-16 x 1" Hex Head Bolt
22	153005	8	3/8" Lock Washer
23	153004	8	3/8" Flat Washer
24*	881109	1	Front Panel Assembly
25	150501	12	5/16-18 x 3/4" Hex Head Machine Bolt
26	153002	12	5/16" Lock Washer
27	153001	12	5/16" Flat Washer
28	115998	180	Tumbler Ring Felt (sold by the inch)
29	152011	4	1/2-13 Hex Nut
30	153050	8	1/2" x 1-1/16" Flat Washer
31	153026	4	1/2" Lock Washer
32	150605	4	1/2-13 x 1-1/2" Hex Head Bolt
33	170365	1	Upper Door Track
34	153007	12	1/4" Lock Washer
35	152002	12	1/4-20 Hex Nut
36	154312	15	#10-32 x 3/4" Socket Head Cap Screw
37*	821244	2	Tumbler Retaining Wheel Cover
38	153018	12	1/4" Flat Washer
39	150523	5	1/4-20 x 3/4" Hex Washer Machine Bolt

* Specify color when ordering.

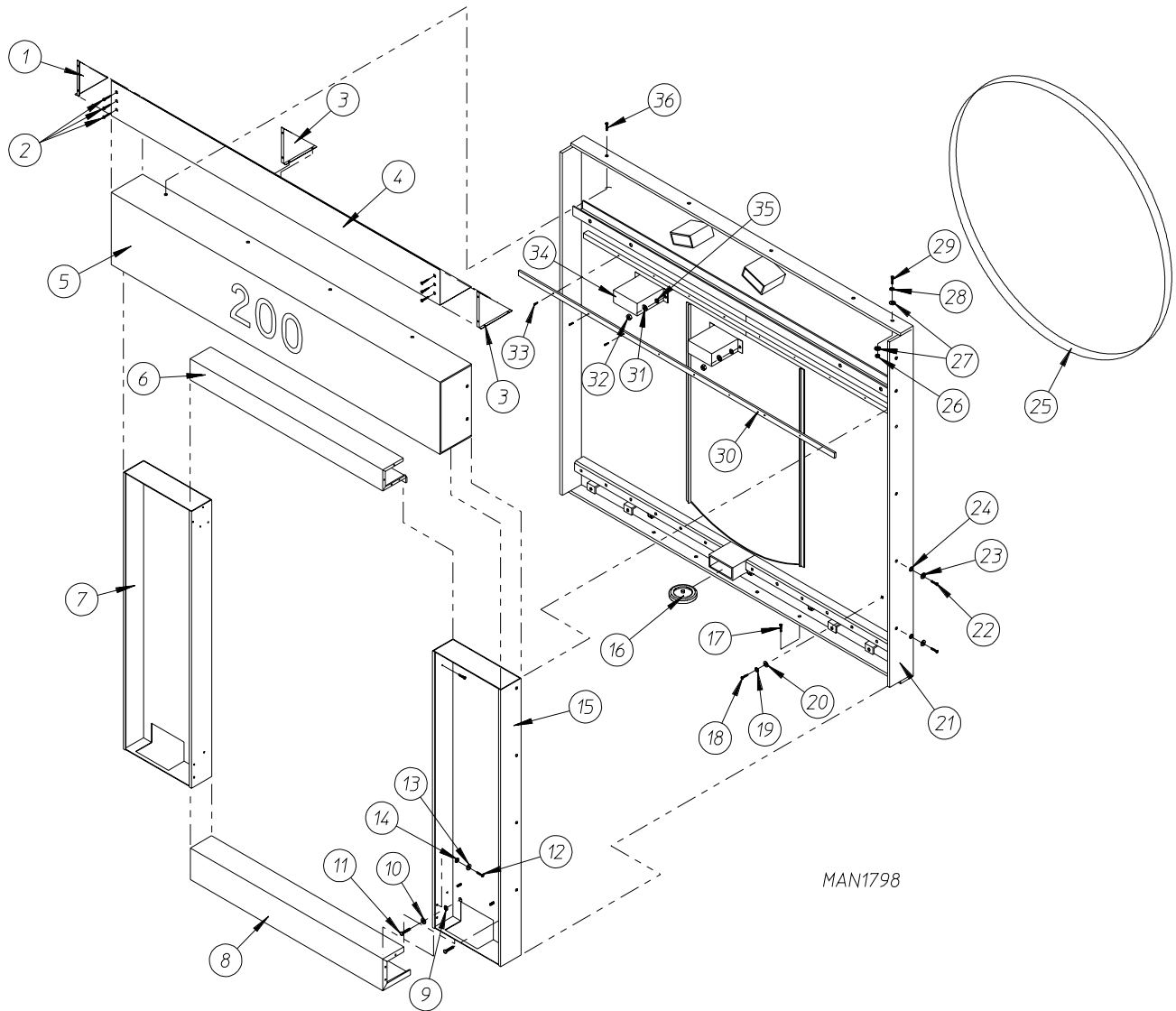

MANUAL DOOR**1-Way Forward Tilt**

<u>Illus. No.</u>	<u>Part No.</u>	<u>Qty.</u>	<u>Description</u>
1	332680	1	Left Gusset (for gas models Only)
2	150522	15	1/4-20 x 1/2" Hex Washer TEK Screw (for gas models Only)
3	332681	2	Right Gusset (for gas models Only)
4*	332679	1	Top Front Panel (for gas models Only)
5*	821241	1	Upper Guard
6*	821239	1	Middle Guard
7*	881114	1	Left Control Door Cabinet
8*	821285	1	Bottom Guard
9	153001	8	5/16" Flat Washer
10	153002	8	5/16" Lock Washer
11	150501	8	5/16-18 x 3/4" Hex Head Machine Bolt
12	150510	12	1/4-20 x 3/4" Hex Head Machine Bolt
13	153007	12	1/4" Lock Washer
14	153018	12	1/4" Flat Washer
15*	881115	1	Right Control Door Cabinet
16	-----	-	Tumbler Retaining Wheel (refer to Tumbler Retaining Wheel Assembly on page 47)
17	150523	5	1/4-20 x 3/4" Hex Washer Machine Bolt
18	150617	8	3/8-16 x 1" Hex Head Bolt
19	153005	8	3/8" Lock Washer
20	153004	8	3/8" Flat Washer
21*	881109	1	Front Panel Assembly
22	150501	12	5/16-18 x 3/4" Hex Head Machine Bolt
23	153002	12	5/16" Lock Washer
24	153001	12	5/16" Flat Washer
25	115998	180	Tumbler Ring Felt (sold by the inch)
26	152011	4	1/2-13 Hex Nut
27	153050	8	1/2" x 1-1/16" Flat Washer
28	153026	4	1/2" Lock Washer
29	150605	4	1/2-13 x 1-1/2" Hex Head Bolt
30	170365	1	Upper Door Track
31	153007	12	1/4" Lock Washer
32	152002	12	1/4-20 Hex Nut
33	154312	15	#10-32 x 3/4" Socket Head Cap Screw
34*	821244	2	Tumbler Retaining Wheel Cover
35	153018	12	1/4" Flat Washer
36	150523	5	1/4-20 x 3/4" Hex Washer Machine Bolt

* Specify color when ordering.

MANUAL DOOR
2-Way Tilt or Rear Tilt ONLY

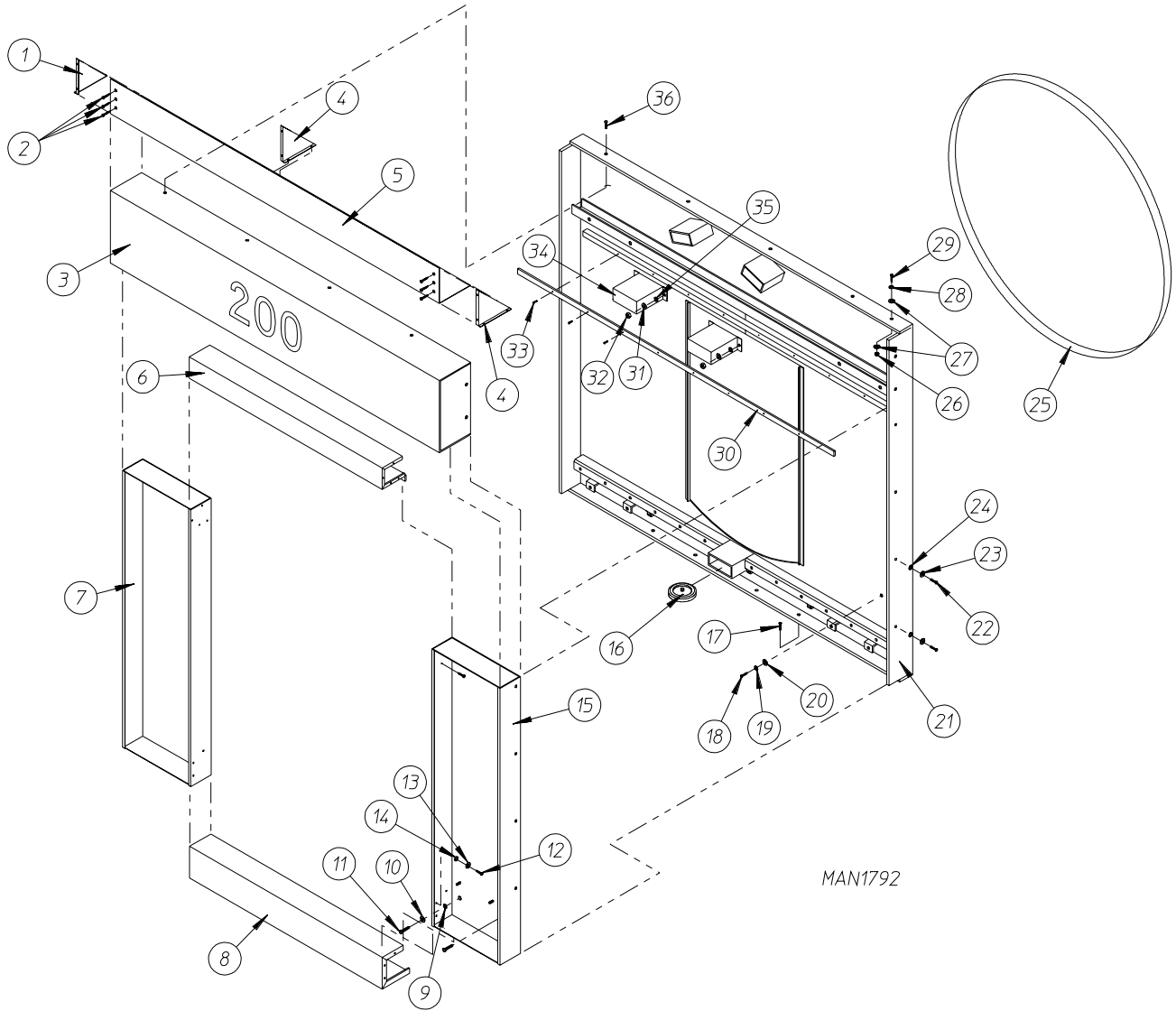

MANUAL DOOR**2-Way Tilt or Rear Tilt ONLY**

<u>Illus. No.</u>	<u>Part No.</u>	<u>Qty.</u>	<u>Description</u>
1	332680	1	Left Gusset (for gas models Only)
2	150522	15	1/4-20 x 1/2" Hex Washer TEK Screw (for gas models Only)
3*	821241	1	Upper Guard
4	332681	2	Right Gusset (for gas models Only)
5*	332679	1	Top Front Panel (for gas models Only)
6*	821239	1	Middle Guard
7*	881117	1	Left Control Door Cabinet
8*	821285	1	Bottom Guard
9	153001	8	5/16" Flat Washer
10	153002	8	5/16" Lock Washer
11	150501	8	5/16-18 x 3/4" Hex Head Machine Bolt
12	150510	12	1/4-20 x 3/4" Hex Head Machine Bolt
13	153007	12	1/4" Lock Washer
14	153018	12	1/4" Flat Washer
15*	881116	1	Right Control Door Cabinet
16	-----	-	Tumbler Retaining Wheel (refer to Tumbler Retaining Wheel Assembly on page 47)
17	150523	5	1/4-20 x 3/4" Hex Washer Machine Bolt
18	150617	8	3/8-16 x 1" Hex Head Bolt
19	153005	8	3/8" Lock Washer
20	153004	8	3/8" Flat Washer
21*	881108	1	Front Panel Assembly
22	150501	12	5/16-18 x 3/4" Hex Head Machine Bolt
23	153002	12	5/16" Lock Washer
24	153001	12	5/16" Flat Washer
25	115998	180	Tumbler Ring Felt (sold by the inch)
26	152011	4	1/2-13 Hex Nut
27	153050	8	1/2" x 1-1/16" Flat Washer
28	153026	4	1/2" Lock Washer
29	150605	4	1/2-13 x 1-1/2" Hex Head Bolt
30	170365	1	Upper Door Track
31	153007	12	1/4" Lock Washer
32	152002	12	1/4-20 Hex Nut
33	154312	15	#10-32 x 3/4" Socket Head Cap Screw
34*	821244	2	Tumbler Retaining Wheel Cover
35	153018	12	1/4" Flat Washer

* Specify color when ordering.

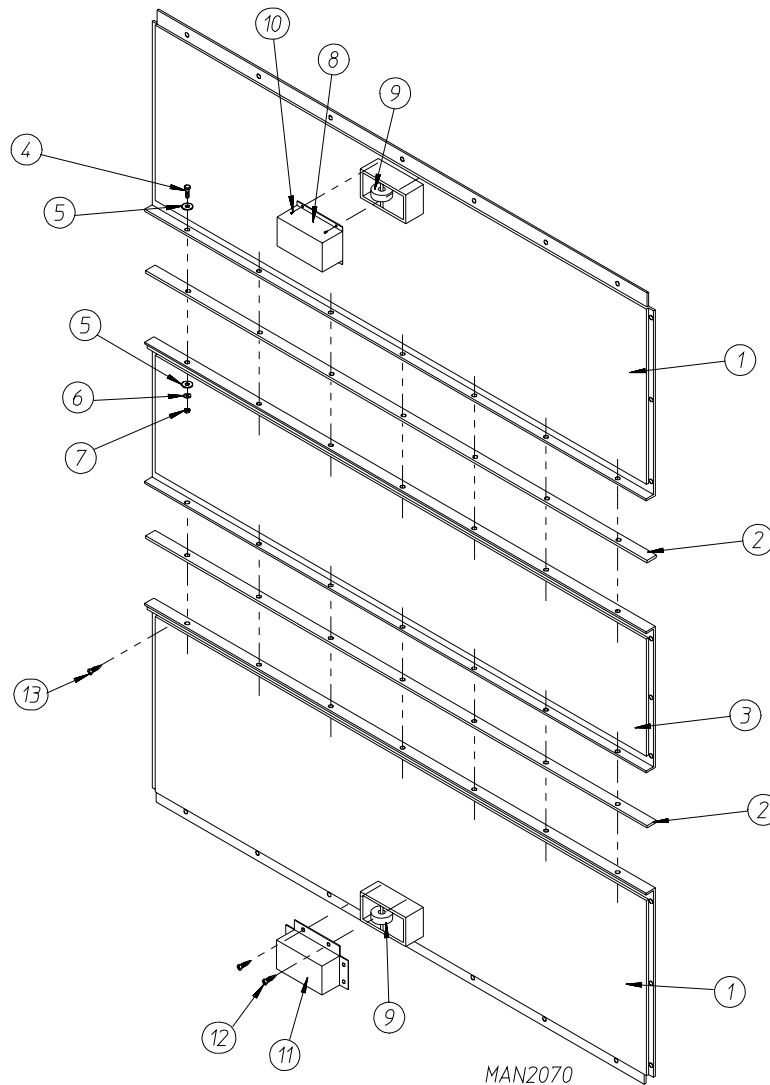

Illus. No.	Part No.	Qty.	Description
1*	821310	2	Top and Bottom Panel Assembly
2	332571	2	Rear Panel Reinforcement
3*	821312	1	Middle Back Panel Assembly
4	150625	14	5/16-18 x 1-1/4" Hex Head Machine Bolt
5	153001	28	5/16" Flat Washer
6	153002	14	5/16" Lock Washer
7	152004	14	5/16-18 Hex Nut
8*	821244	1	Tumbler Retaining Wheel Cover
9	-----	2	Tumbler Retaining Wheel (refer to Tumbler Retaining Wheel Assembly on page 47)
10	150301	4	#8-18 x 7/16" Phillips Pan Head TEK Screw
11*	332787	1	Tumbler Retaining Wheel Guard
12	150301	6	#8-18 x 7/16" Phillips Pan Head TEK Screw
13	150523	32	1/4-20 x 3/4" Hex Head Machine Bolt

* Specify color when ordering.

1 Door/2-Way Tilt

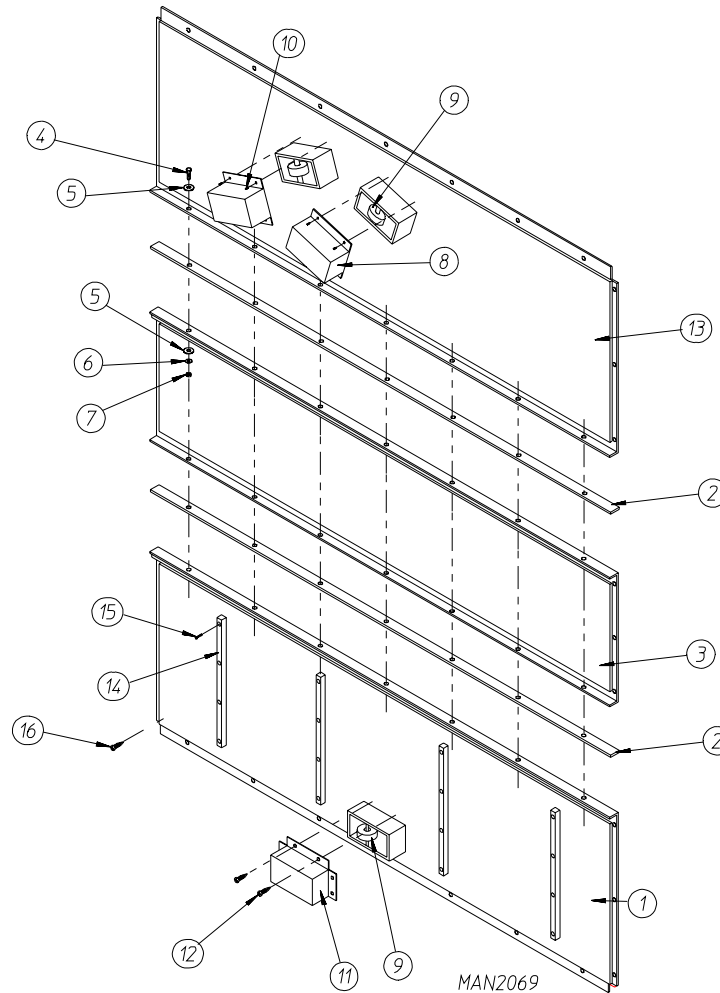

Illus. No.	Part No.	Qty.	Description
1*	821310	1	Bottom Back Panel Assembly
2	332571	2	Rear Panel Reinforcement
3*	821312	1	Middle Back Panel Assembly
4	150625	14	5/16-18 x 1-1/4" Hex Head Machine Bolt
5	153001	28	5/16" Flat Washer
6	153002	14	5/16" Lock Washer
7	152004	14	5/16-18 Hex Nut
8*	821244	2	Tumbler Retaining Wheel Cover
9	-----	3	Tumbler Retaining Wheel (refer to Tumbler Retaining Wheel Assembly on page 47)
10	150301	8	#8-18 x 7/16" Phillips Pan Head TEK Screw
11*	332787	1	Tumbler Retaining Wheel Guard
12	150301	6	#8-18 x 7/16" Phillips Pan Head TEK Screw
13*	881118	1	Top Back Panel Assembly
14	170346	4	Nylon Guide
15	150415	16	#10-16 x 1/2" Phillips Round Head Crimptite Screw
16	150523	32	1/4-20 x 3/4" Hex Head Machine Bolt

* Specify color when ordering.

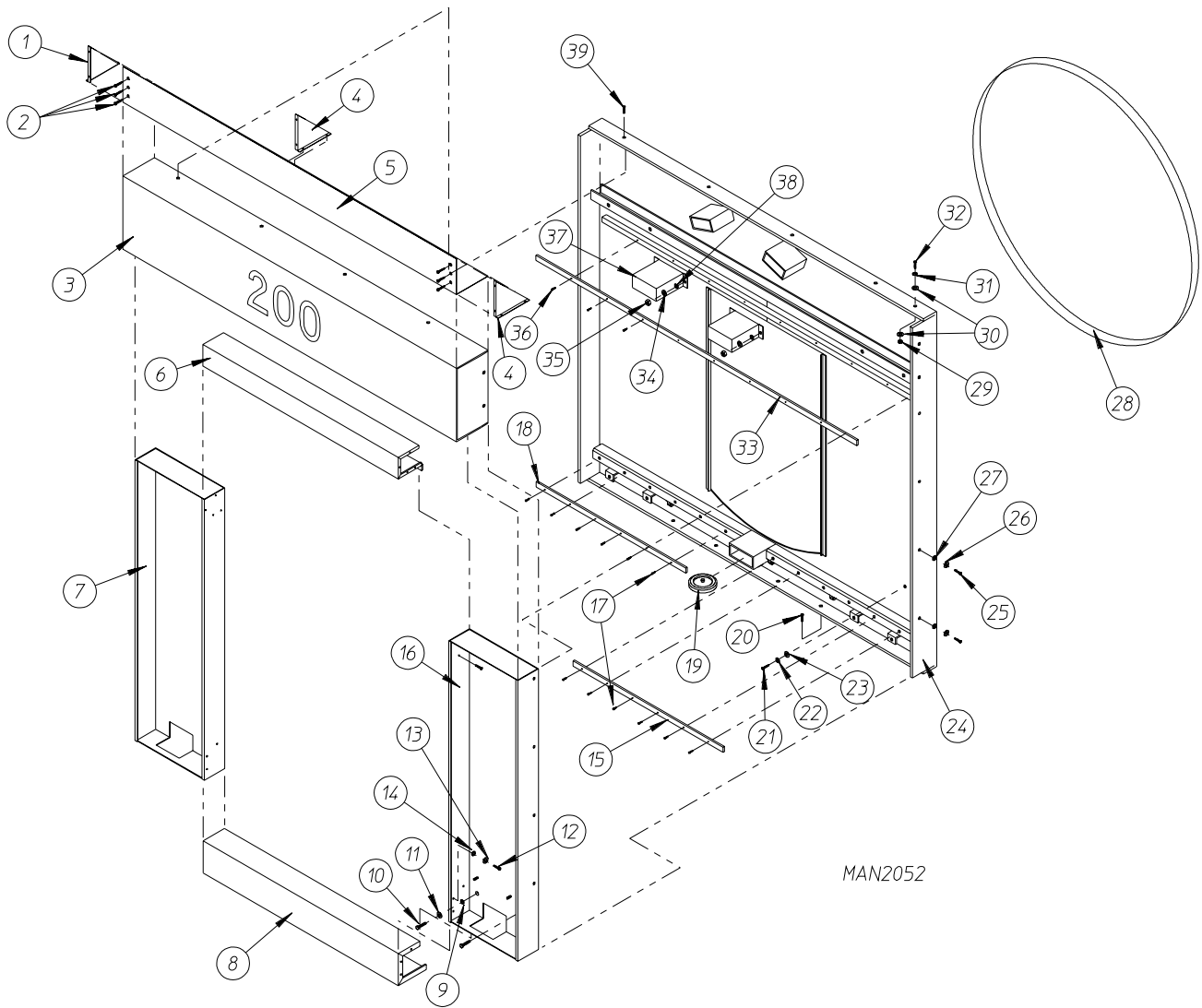

AUTOMATIC DOOR**Rear Tilt ONLY**

<u>Illus. No.</u>	<u>Part No.</u>	<u>Qty.</u>	<u>Description</u>
1	332680	1	Left Gusset (for gas models Only)
2	150522	15	1/4-20 x 1/2" Hex Washer TEK Screw (for gas models Only)
3*	821241	1	Upper Guard
4	332681	2	Right Gusset (for gas models Only)
5*	332679	1	Top Front Panel (for gas models Only)
6*	821239	1	Middle Guard
7*	881114	1	Left Control Door Cabinet
8*	821285	1	Bottom Guard
9	153001	8	5/16" Flat Washer
10	150501	8	5/16-18 x 3/4" Hex Head Machine Bolt
11	153002	8	5/16" Lock Washer
12	150510	12	1/4-20 x 3/4" Hex Head Machine Bolt
13	153007	12	1/4" Lock Washer
14	153018	12	1/4" Flat Washer
15	170364	1	Bottom Door Track
16*	881115	1	Right Control Door Cabinet
17	154312	14	#10-32 x 3/4" Socket Head Cap Screw
18	170364	1	Bottom Door Track
19	-----	-	Tumbler Retaining Wheel (refer to Tumbler Retaining Wheel Assembly on page 47)
20	150523	5	1/4-20 x 3/4" Hex Washer Machine Bolt
21	150617	8	3/8-16 x 1" Hex Head Bolt
22	153005	8	3/8" Lock Washer
23	153004	8	3/8" Flat Washer
24*	881109	1	Front Panel Assembly
25	150501	12	5/16-18 x 3/4" Hex Head Machine Bolt
26	153002	12	5/16" Lock Washer
27	153001	12	5/16" Flat Washer
28	115998	180	Tumbler Ring Felt (sold by the inch)
29	152011	4	1/2-13 Hex Nut
30	153050	8	1/2" x 1-1/16" Flat Washer
31	153026	4	1/2" Lock Washer
32	150605	4	1/2-13 x 1-1/2" Hex Head Bolt
33	170365	1	Upper Door Track
34	153007	12	1/4" Lock Washer
35	152002	12	1/4-20 Hex Nut
36	154312	15	#10-32 x 3/4" Socket Head Cap Screw
37*	821244	2	Tumbler Retaining Wheel Cover
38	153018	12	1/4" Flat Washer
39	150523	5	1/4-20 x 3/4" Hex Washer Machine Bolt

* Specify color when ordering.

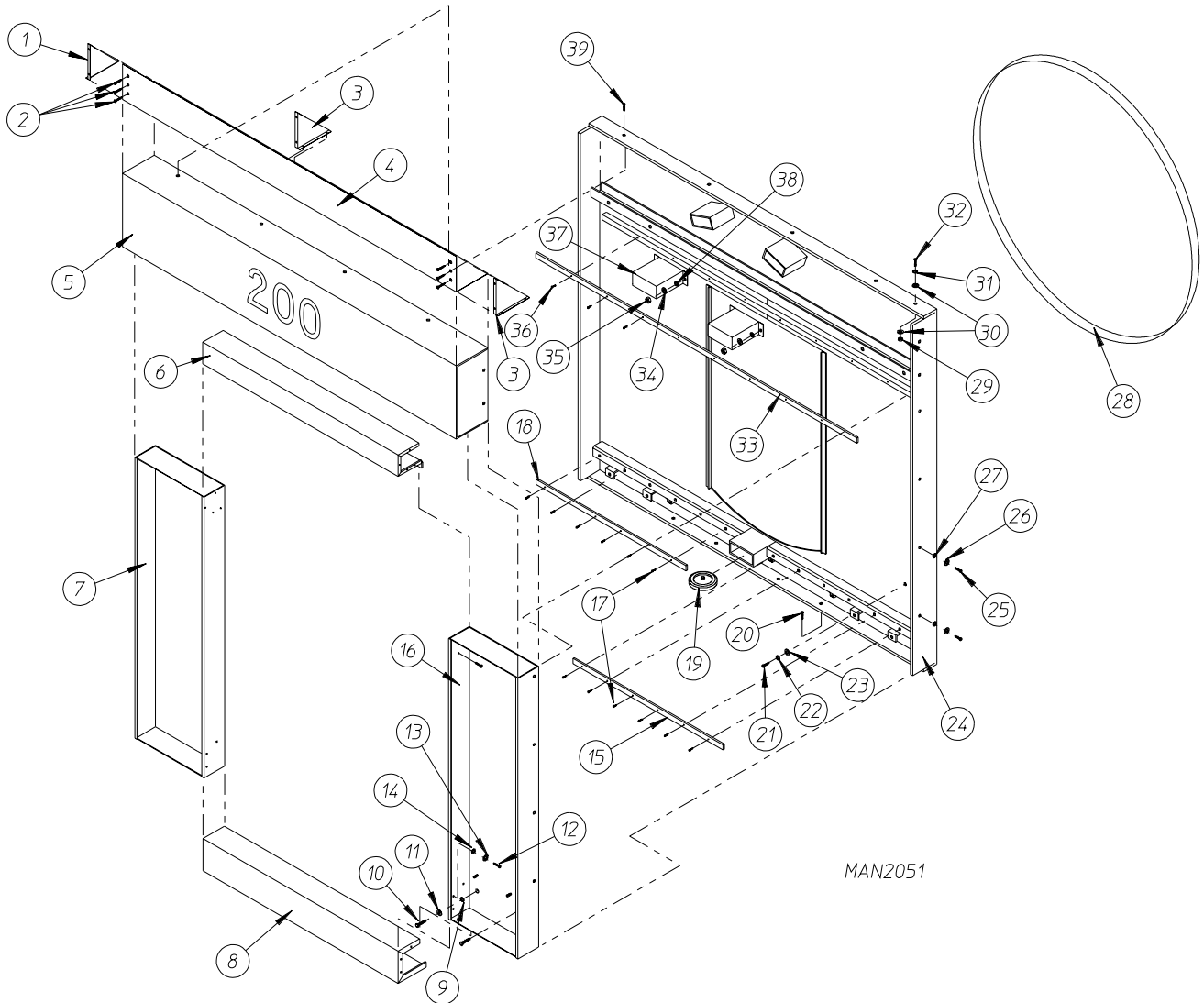

AUTOMATIC DOOR**2-Way Tilt**

<u>Illus. No.</u>	<u>Part No.</u>	<u>Qty.</u>	<u>Description</u>
1	332680	1	Left Gusset (for gas models Only)
2	150522	15	1/4-20 x 1/2" Hex Washer TEK Screw (for gas models Only)
3	332681	2	Right Gusset (for gas models Only)
4*	332679	1	Top Front Panel (for gas models Only)
5*	821241	1	Upper Guard
6*	821239	1	Middle Guard
7*	881117	1	Left Control Door Cabinet
8*	821285	1	Bottom Guard
9	153001	8	5/16" Flat Washer
10	150501	8	5/16-18 x 3/4" Hex Head Machine Bolt
11	153002	8	5/16" Lock Washer
12	150510	12	1/4-20 x 3/4" Hex Head Machine Bolt
13	153007	12	1/4" Lock Washer
14	153018	12	1/4" Flat Washer
15	170364	1	Bottom Door Track
16*	881116	1	Right Control Door Cabinet
17	154312	14	#10-32 x 3/4" Socket Head Cap Screw
18	170364	1	Bottom Door Track
19	-----	-	Tumbler Retaining Wheel (refer to Tumbler Retaining Wheel Assembly on page 47)
20	150523	5	1/4-20 x 3/4" Hex Washer Machine Bolt
21	150617	8	3/8-16 x 1" Hex Head Bolt
22	153005	8	3/8" Lock Washer
23	153004	8	3/8" Flat Washer
24*	881109	1	Front Panel Assembly
25	150501	12	5/16-18 x 3/4" Hex Head Machine Bolt
26	153002	12	5/16" Lock Washer
27	153001	12	5/16" Flat Washer
28	115998	180	Tumbler Ring Felt (sold by the inch)
29	152011	4	1/2-13 Hex Nut
30	153050	8	1/2" x 1-1/16" Flat Washer
31	153026	4	1/2" Lock Washer
32	150605	4	1/2-13 x 1-1/2" Hex Head Bolt
33	170365	1	Upper Door Track
34	153007	12	1/4" Lock Washer
35	152002	12	1/4-20 Hex Nut
36	154312	15	#10-32 x 3/4" Socket Head Cap Screw
37*	821244	2	Tumbler Retaining Wheel Cover
38	153018	12	1/4" Flat Washer
39	150523	5	1/4-20 x 3/4" Hex Washer Machine Bolt

* Specify color when ordering.

MANUAL DOOR
Rear Tilt ONLY

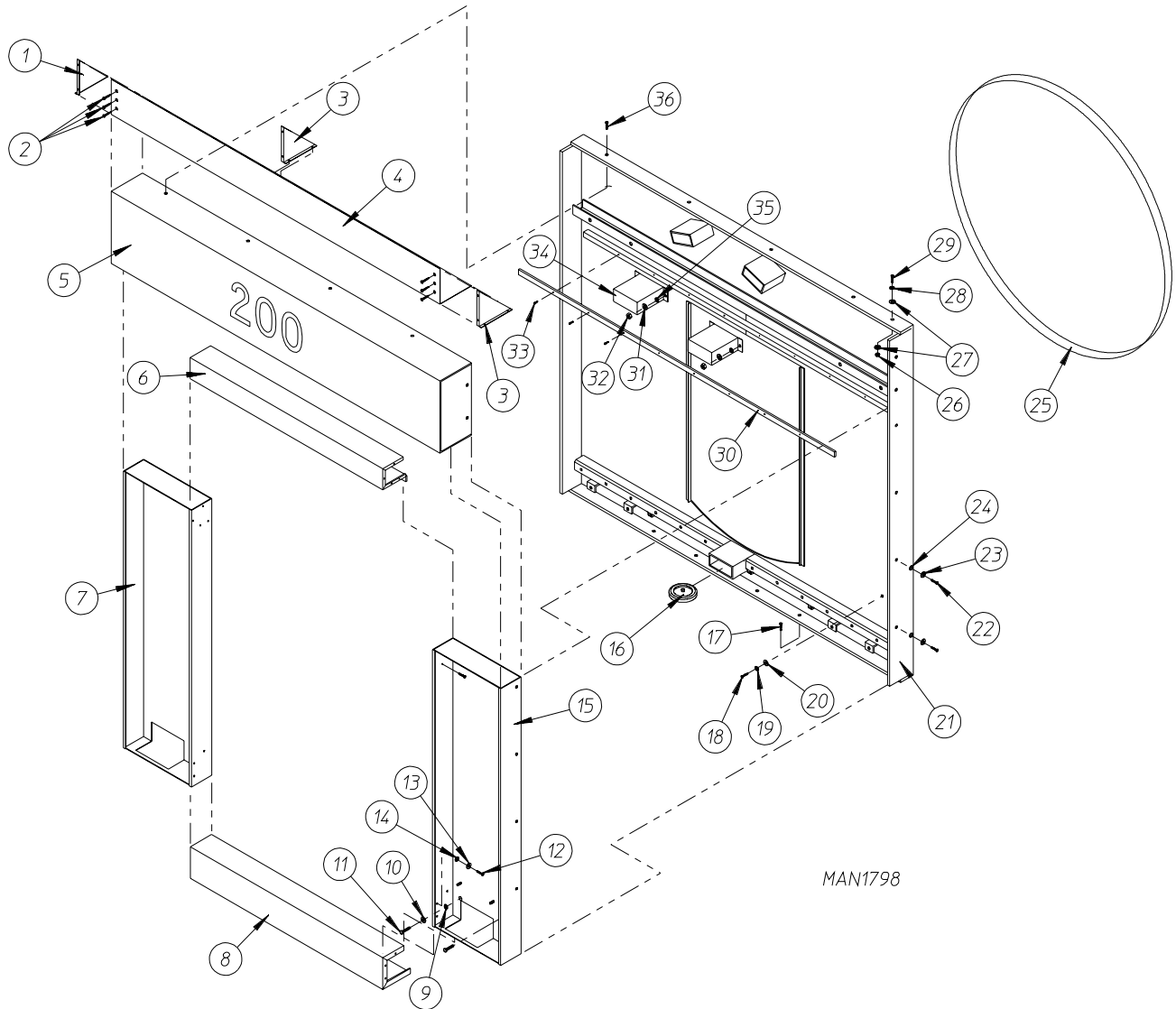

MANUAL DOOR**Rear Tilt ONLY**

<u>Illus. No.</u>	<u>Part No.</u>	<u>Qty.</u>	<u>Description</u>
1	332680	1	Left Gusset (for gas models Only)
2	150522	15	1/4-20 x 1/2" Hex Washer TEK Screw (for gas models Only)
3	332681	2	Right Gusset (for gas models Only)
4*	332679	1	Top Front Panel (for gas models Only)
5*	821241	1	Upper Guard
6*	821239	1	Middle Guard
7*	881114	1	Left Control Door Cabinet
8*	821285	1	Bottom Guard
9	153001	8	5/16" Flat Washer
10	153002	8	5/16" Lock Washer
11	150501	8	5/16-18 x 3/4" Hex Head Machine Bolt
12	150510	12	1/4-20 x 3/4" Hex Head Machine Bolt
13	153007	12	1/4" Lock Washer
14	153018	12	1/4" Flat Washer
15*	881115	1	Right Control Door Cabinet
16	-----	-	Tumbler Retaining Wheel (refer to Tumbler Retaining Wheel Assembly on page 47)
17	150523	5	1/4-20 x 3/4" Hex Washer Machine Bolt
18	150617	8	3/8-16 x 1" Hex Head Bolt
19	153005	8	3/8" Lock Washer
20	153004	8	3/8" Flat Washer
21*	881108	1	Front Panel Assembly
22	150501	12	5/16-18 x 3/4" Hex Head Machine Bolt
23	153002	12	5/16" Lock Washer
24	153001	12	5/16" Flat Washer
25	115995	180	Tumbler Ring Felt (sold by the inch)
26	152011	4	1/2-13 Hex Nut
27	153050	8	1/2" x 1-1/16" Flat Washer
28	153026	4	1/2" Lock Washer
29	150605	4	1/2-13 x 1-1/2" Hex Head Bolt
30	170365	1	Upper Door Track
31	153007	12	1/4" Lock Washer
32	152002	12	1/4-20 Hex Nut
33	154312	15	#10-32 x 3/4" Socket Head Cap Screw
34*	821244	2	Tumbler Retaining Wheel Cover
35	153018	12	1/4" Flat Washer
36	150523	5	1/4-20 x 3/4" Hex Washer Machine Bolt

* Specify color when ordering.

MANUAL DOOR
2-Way Tilt

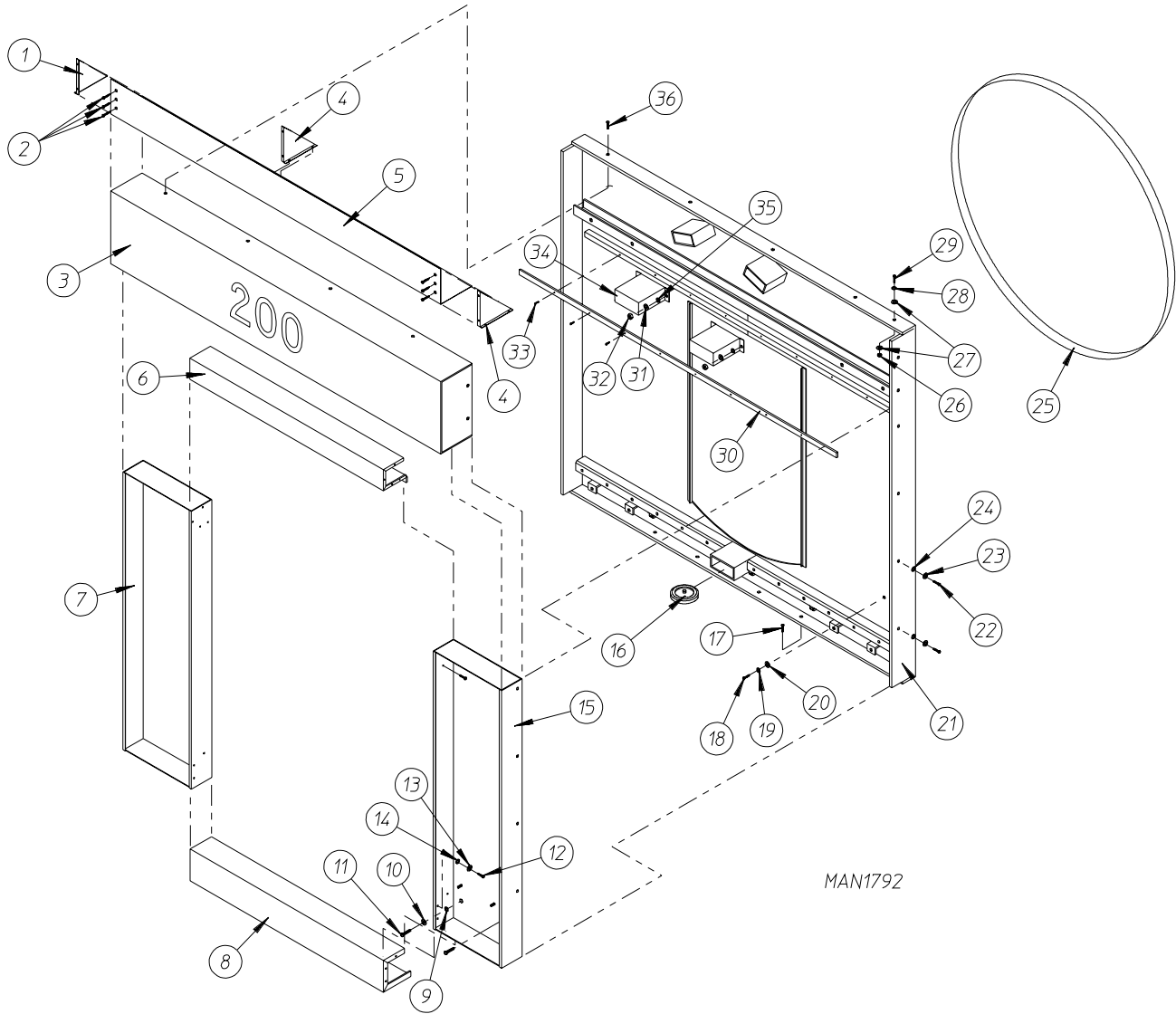

MANUAL DOOR**2-Way Tilt**

<u>Illus. No.</u>	<u>Part No.</u>	<u>Qty.</u>	<u>Description</u>
1	332680	1	Left Gusset (for gas models Only)
2	150522	15	1/4-20 x 1/2" Hex Washer TEK Screw (for gas models Only)
3*	821241	1	Upper Guard
4	332681	2	Right Gusset (for gas models Only)
5*	332679	1	Top Front Panel (for gas models Only)
6*	821239	1	Middle Guard
7*	881117	1	Left Control Door Cabinet
8*	821285	1	Bottom Guard
9	153001	8	5/16" Flat Washer
10	153002	8	5/16" Lock Washer
11	150501	8	5/16-18 x 3/4" Hex Head Machine Bolt
12	150510	12	1/4-20 x 3/4" Hex Head Machine Bolt
13	153007	12	1/4" Lock Washer
14	153018	12	1/4" Flat Washer
15*	881116	1	Right Control Door Cabinet
16	-----	-	Tumbler Retaining Wheel (refer to Tumbler Retaining Wheel Assembly on page 47)
17	150523	5	1/4-20 x 3/4" Hex Washer Machine Bolt
18	150617	8	3/8-16 x 1" Hex Head Bolt
19	153005	8	3/8" Lock Washer
20	153004	8	3/8" Flat Washer
21*	881108	1	Front Panel Assembly
22	150501	12	5/16-18 x 3/4" Hex Head Machine Bolt
23	153002	12	5/16" Lock Washer
24	153001	12	5/16" Flat Washer
25	115995	180	Tumbler Ring Felt (sold by the inch)
26	152011	4	1/2-13 Hex Nut
27	153050	8	1/2" x 1-1/16" Flat Washer
28	153026	4	1/2" Lock Washer
29	150605	4	1/2-13 x 1-1/2" Hex Head Bolt
30	170365	1	Upper Door Track
31	153007	12	1/4" Lock Washer
32	152002	12	1/4-20 Hex Nut
33	154312	15	#10-32 x 3/4" Socket Head Cap Screw
34*	821244	2	Tumbler Retaining Wheel Cover
35	153018	12	1/4" Flat Washer

* Specify color when ordering.

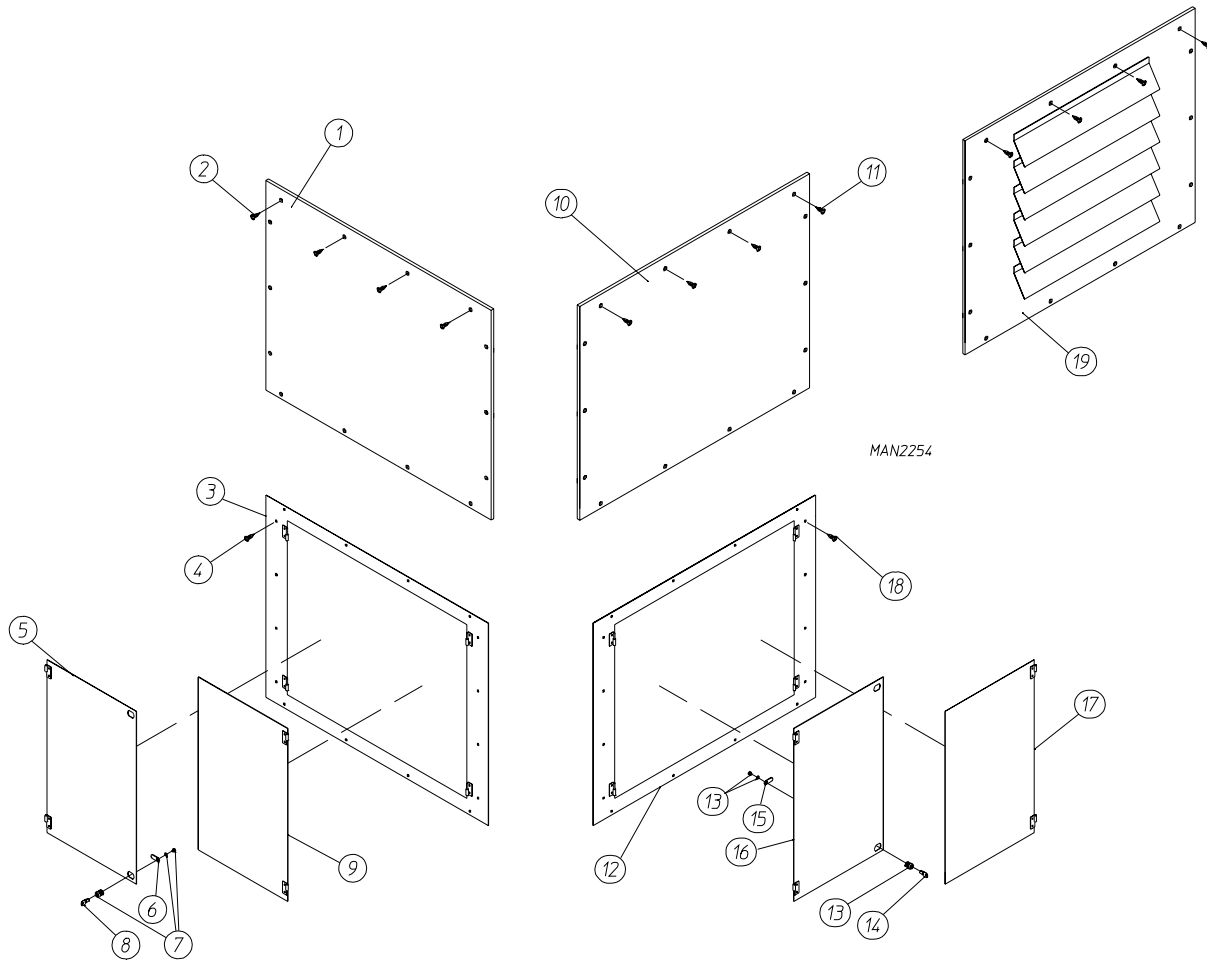

<u>Illus. No.</u>	<u>Part No.</u>	<u>Qty.</u>	<u>Description</u>
1*	821283	1	Left Top Side Panel
2	150523	14	1/4-20 x 3/4" Hex Head TEK Screw
3*	881189	1	Lower Side Panel for Hinged Doors
4	150523	16	1/4-20 x 3/4" Hex Head TEK Screw
5*	881190	1	Locking Hinged Side Panel Door Less Locks
6	160034	2	Lock Cam ONLY
7	160050	2	ACE® Door Lock ONLY Less Key (keyed to #XX4451)
8	160140	2	ACE® XX4451 Key ONLY
9*	881191	1	Hinged Side Panel Door Assembly
10*	881283	1	Right Top Side Panel (for steam models Only)
11	150523	14	1/4-20 x 3/4" Hex Head TEK Screw
12*	881189	1	Lower Side Panel for Hinged Doors
13	160050	2	ACE® Door Lock ONLY Less Key (keyed to #XX4451)
14	160140	2	ACE® XX4451 Key ONLY
15	160034	2	Lock Cam ONLY
16*	881190	1	Locking Hinged Side Panel Door Less Locks
17*	881191	1	Hinged Side Panel Door Assembly
18	150523	16	1/4-20 x 3/4" Hex Head TEK Screw
19*	821242	1	Top Right Side Panel (for gas models Only)

* Specify color when ordering.

For 1 Door or 2 Door Models

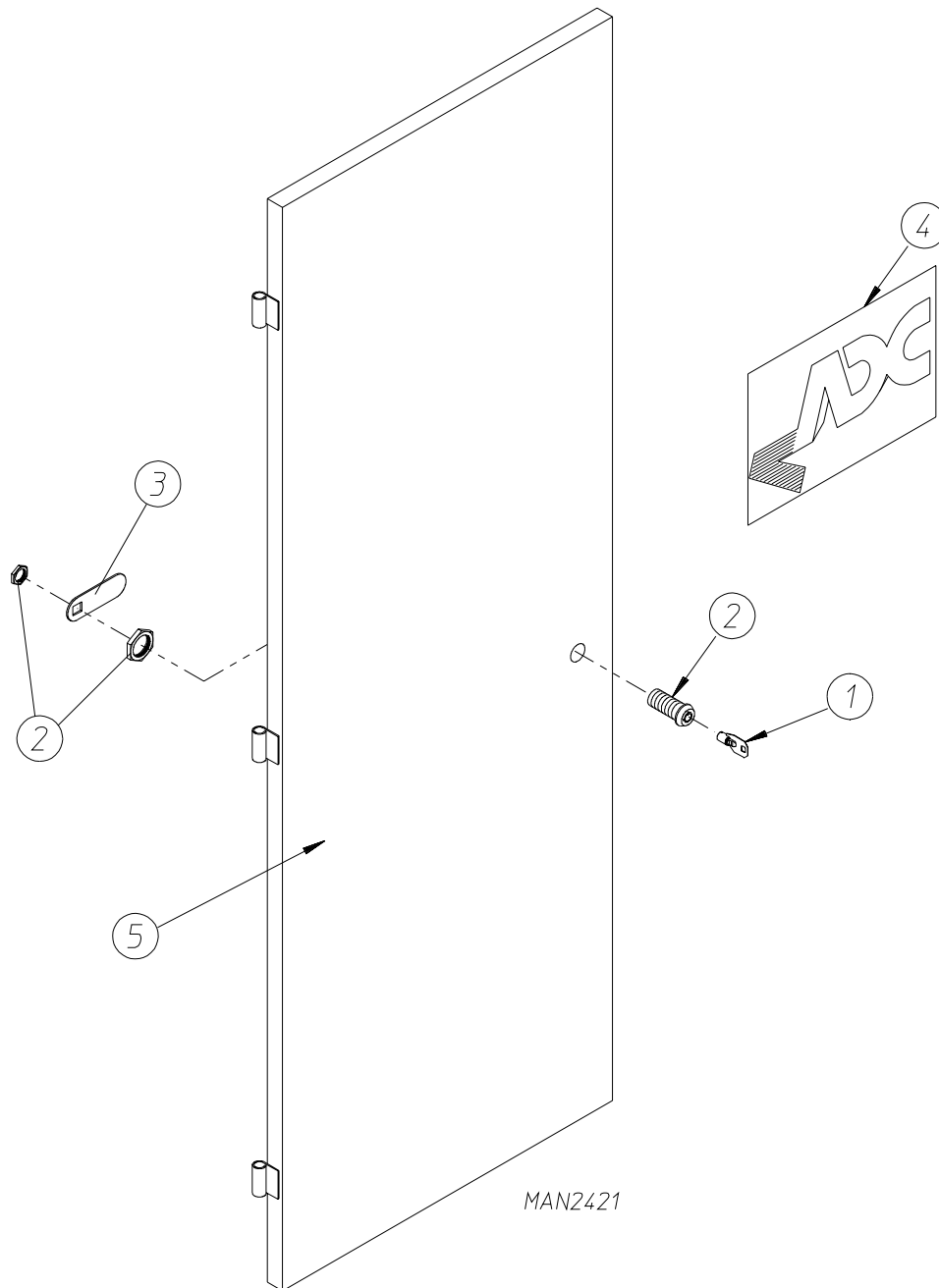

Illus. No.	Part No.	Qty.	Description
1	160140	1	ACE® XX4451 Key ONLY
2	160050	1	ACE® Control Door Lock ONLY Less Key (keyed to #XX4451)
3	160014	1	Cam ONLY
4	112360	1	ADC Logo ONLY (tape kit not included)
	870011	1	Logo Double Tape Kit
5*	821334	1	Left Hand Control Door

* Specify color when ordering.

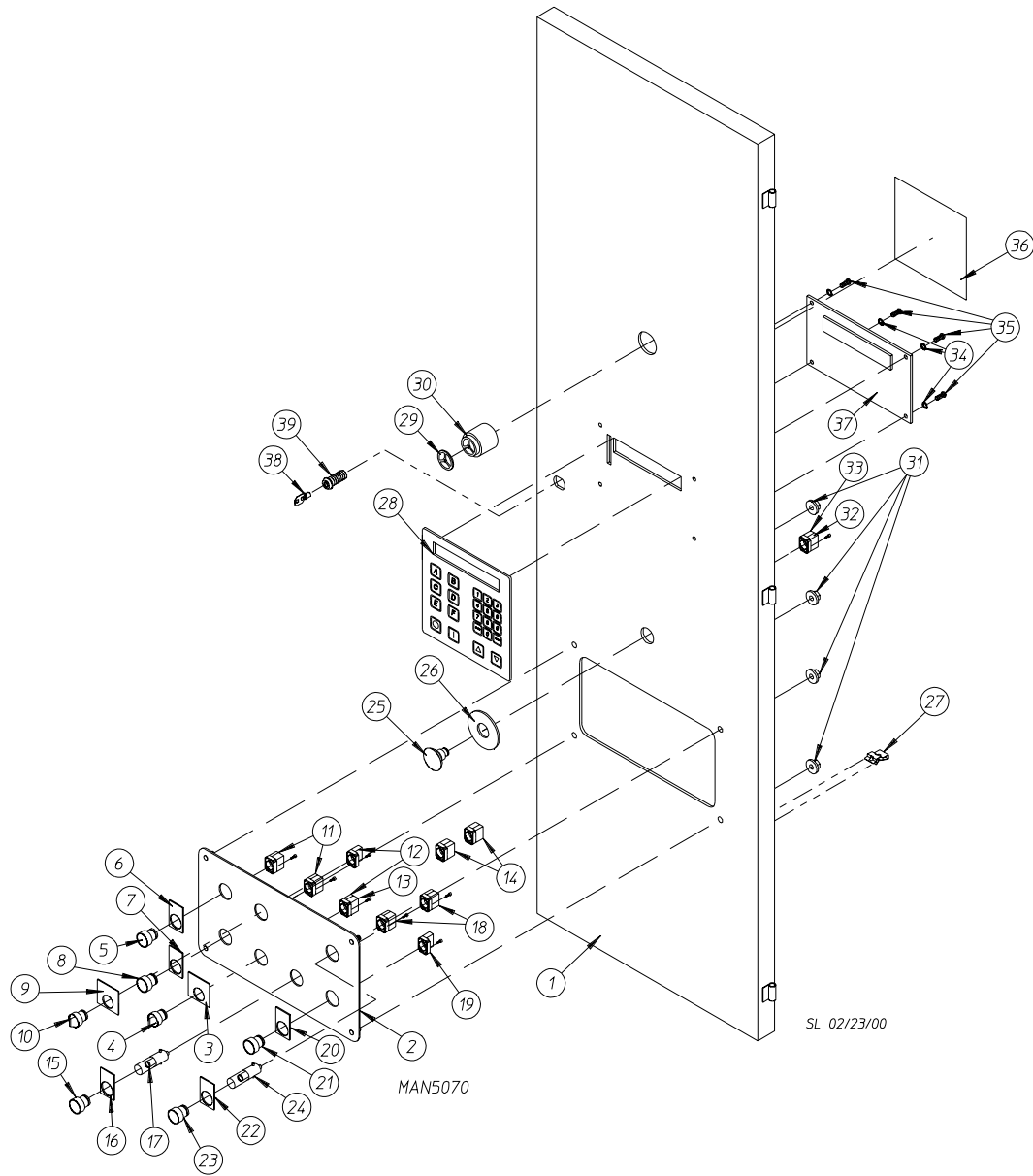

Illus. No. Part No. Qty. Description

1	821597	1	Front Right Control Door ONLY
2	-----	1	Front Right Control Door Panel ONLY (refer to Right Rear/Front Control Panel on page 94)
3	122438	1	Engraved Nameplate: Load - Dry - Unload
4	122361	1	3-Position Maintained Operator
5	123203	1	Black Push Button Operator
6	122415	1	Engraved Nameplate: Forward
7	122416	1	Engraved Nameplate: Reverse
8	123202	1	White Push Button Operator
9	122413	1	Engraved Nameplate: Tilt Off - Tilt On
10	122360	1	2-Position Maintained Operator
11	132396	2	Mounting Base with N.O. and N.C. Contact Block
12	132394	2	Mounting Base with N.O. Contact Block

<u>Illus. No.</u>	<u>Part No.</u>	<u>Qty.</u>	<u>Description</u>
13	132386	1	Normally Open Contact Block
14	132387	4	Normally Closed Contact Block
15	123201	1	Green Lighted Push Button Operator
16	122410	1	Engraved Nameplate: ON
17	123212	1	24 Volt Lamp
18	132388	2	Normally Open Contact Block with Direct Supply
19	132395	1	Mounting Base with Normally Closed Contact Block
20	122421	1	Engraved Nameplate: OFF
21	123204	1	Red Push Button Operator
22	122420	1	Sprinkler Stop Nameplate
23	123200	1	Amber Lighted Push Button Operator
24	123212	1	24 Volt Lamp
25	122351	1	“EMERGENCY STOP” Operator
26	122419	1	Engraved “EMERGENCY STOP” Label
27	121509	6	Tie Wrap Clips
28	112571	1	Phase 7 Keyboard
29	134018	1	Alarm Horn Volume Control
30	128967	1	80-90 Decibel Panel Mount Alarm Horn
31	152014	4	1/4-20 Free Spin Wash Nuts
32	132395	1	Mounting Base with Normally Closed Contact Block
33	132387	1	Normally Closed Contact Block
34	153010	4	#6 Star Washer
35	150005	4	#6-32 x 1/4” Phillips Round Head Machine Screw
36	122426	1	Caution Label
37	137245	1	Phase 7 Display Board

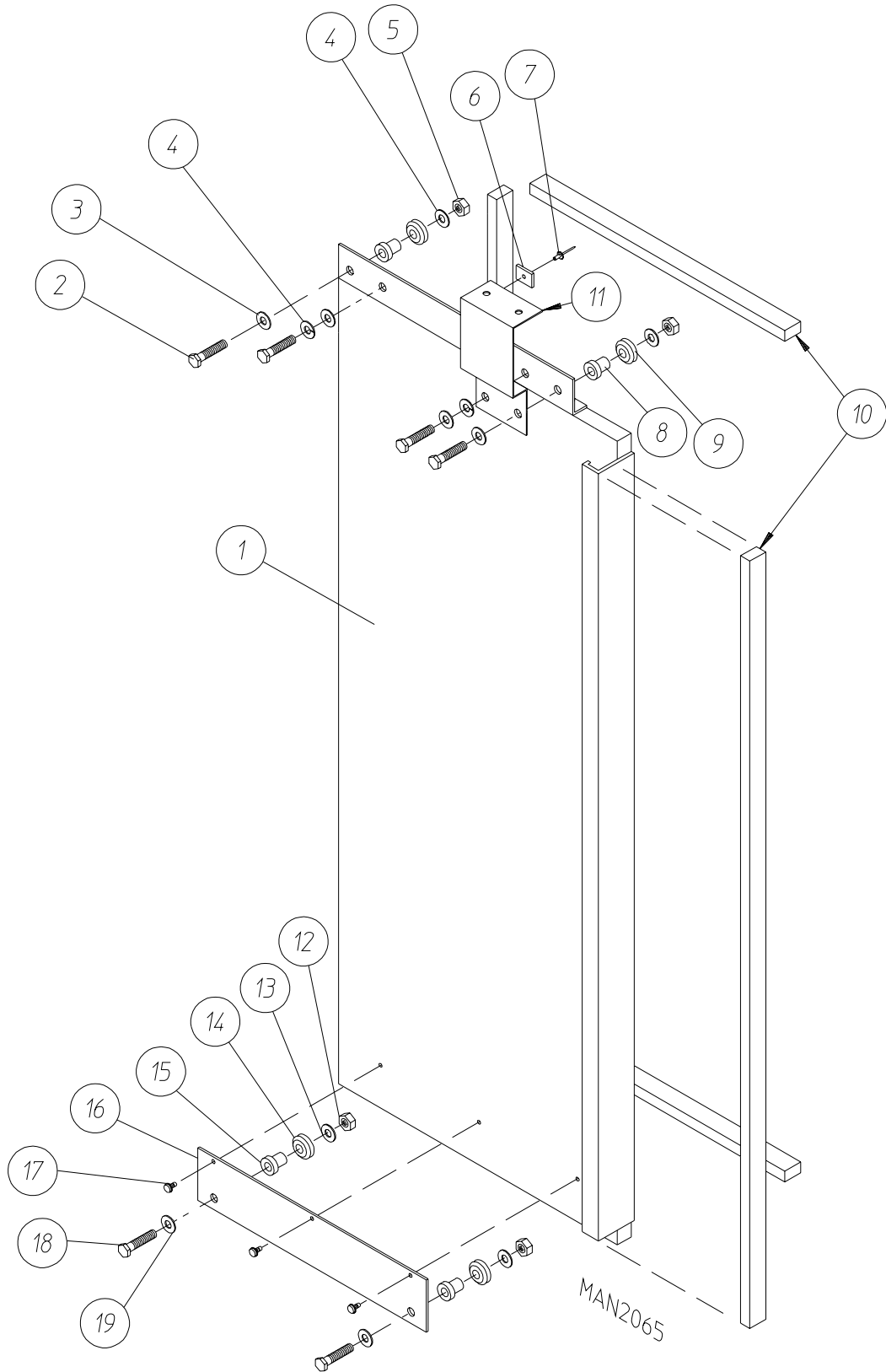

AUTOMATIC DOOR

<u>Illus. No.</u>	<u>Part No.</u>	<u>Qty.</u>	<u>Description</u>
1*	881112	1	Left Automatic Load Door Assembly Complete (includes illus. nos. 1 through 11)
	881106	1	Left Automatic Load Door ONLY
2	150112	4	1/4-20 x 1-1/4" Hex Head Machine Screw
3	153018	4	1/4" Flat Washer
4	153007	4	1/4" Lock Washer
5	152002	2	1/4-20 Hex Nut
6	102102	1	Door Magnet
7	154200	1	5/32" Pop Rivet
8	170367	2	Stainless Steel Stationary Bushing
9	170366	2	Stainless Steel Sealed Wheel
10	115995	125	Felt Gasket (sold by the inch)
11*	334134	1	Automatic Door Bracket
12	152002	2	1/4-20 Hex Nut
13	153007	2	1/4" Lock Washer
14	170366	2	Stainless Steel Sealed Wheel
15	170367	2	Stainless Steel Stationary Bushing
16*	881133	1	Lower Trolley Assembly Complete (includes illus. nos. 12 through 16, 18, and 19)
	334123	1	Lower Trolley ONLY
17	150301	3	#8-18 x 7/16" Phillips Pan Head TEK Screw
18	150112	2	1/4-20 x 1-1/4" Hex Head Machine Screw
19	153018	2	1/4" Flat Washer

* Specify color when ordering.

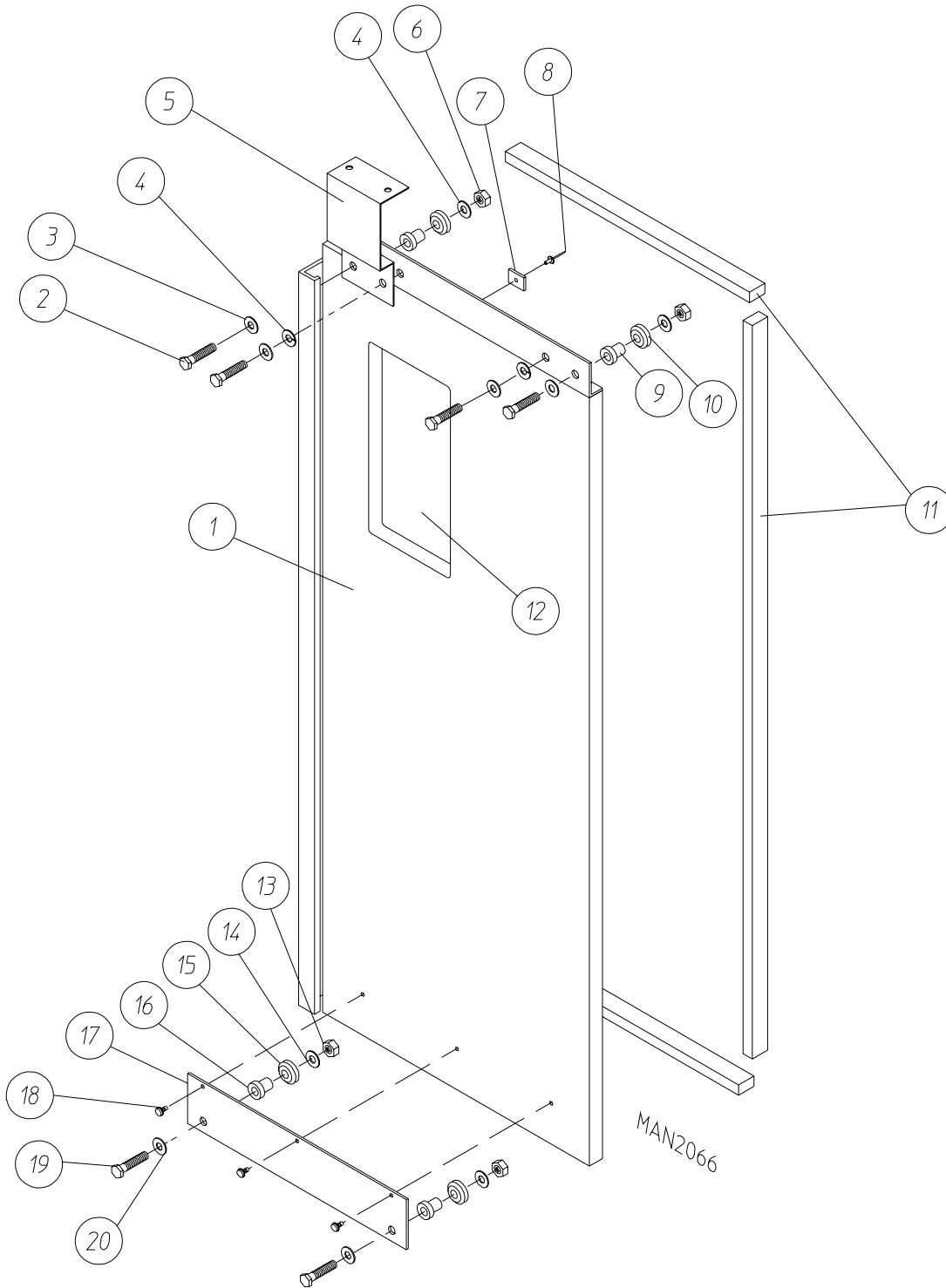

AUTOMATIC DOOR

<u>Illus. No.</u>	<u>Part No.</u>	<u>Qty.</u>	<u>Description</u>
1*	881113	1	Right Automatic Load Door Assembly Complete (includes illus. nos. 1 through 12)
	881107	1	Right Automatic Load Door ONLY
2	150112	4	1/4-20 x 1-1/4" Hex Head Machine Screw
3	153018	4	1/4" Flat Washer
4	153007	4	1/4" Lock Washer
5*	334134	1	Automatic Door Bracket
6	152002	2	1/4-20 Hex Nut
7	102102	1	Door Magnet
8	154200	1	5/32" Pop Rivet
9	170367	2	Stainless Steel Stationary Bushing
10	170366	2	Stainless Steel Sealed Wheel
11	115995	80	Felt Gasket (sold by the inch)
12	102215	1	Door Window
	170730	-	Door Window Adhesive (10.3 oz. cartridge)
13	152002	2	1/4-20 Hex Nut
14	153007	2	1/4" Lock Washer
15	170366	2	Stainless Steel Sealed Wheel
16	170367	2	Stainless Steel Stationary Bushing
17*	881133	1	Lower Trolley Assembly Complete (includes illus. nos. 13 through 17, 19, and 20)
	334123	1	Lower Trolley ONLY
18	150301	3	#8-18 x 7/16" Phillips Pan Head TEK Screw
19	152112	2	1/4-20 x 1-1/4" Hex Head Machine Screw
20	153018	2	1/4" Flat Washer

* Specify color when ordering.

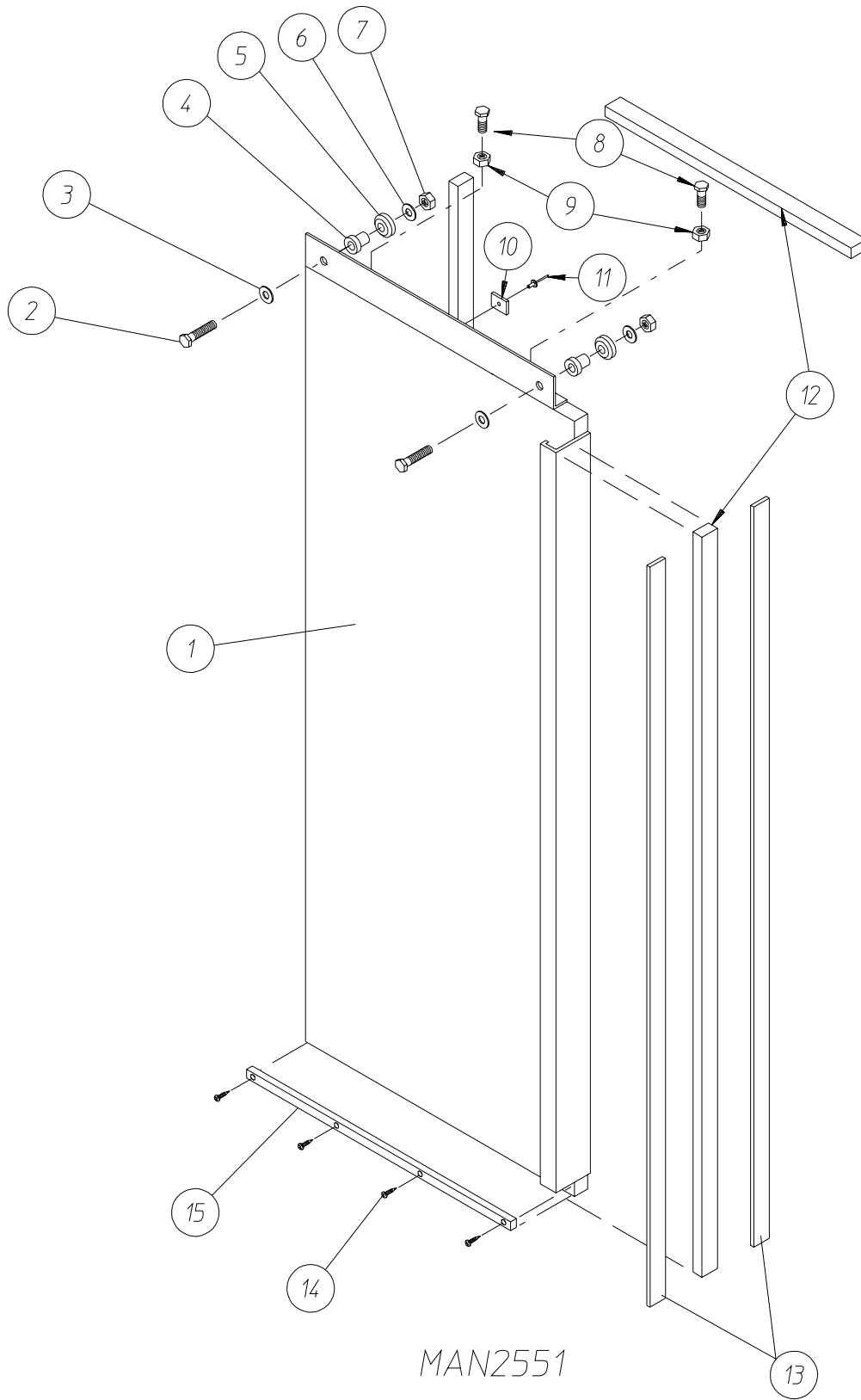

MANUAL DOOR

<u>Illus. No.</u>	<u>Part No.</u>	<u>Qty.</u>	<u>Description</u>
1*	821728	1	Left Manual Load Door Assembly Complete (includes illus. nos. 1 through 15)
2	150112	2	1/4-20 x 1-1/4" Hex Head Machine Screw
3	153018	2	1/4" Flat Washer
4	170367	2	Stainless Steel Stationary Bushing
5	170366	2	Stainless Steel Sealed Wheel
6	153007	4	1/4" Lock Washer
7	152002	2	1/4-20 Hex Nut
8	150512	2	1/4-20 x 1/2" Hex Head Machine Bolt
9	152002	2	1/4-20 Hex Nut
10	102102	1	Door Magnet
11	154200	1	5/32" Pop Rivet
12	115995	125	Felt Gasket (sold by the inch)
13	102111	2	Door Magnet
14	150301	4	#8-18 x 7/16" Phillips Pan Head TEK Screw
15	170357	1	Lower Door Slide

* Specify color when ordering.

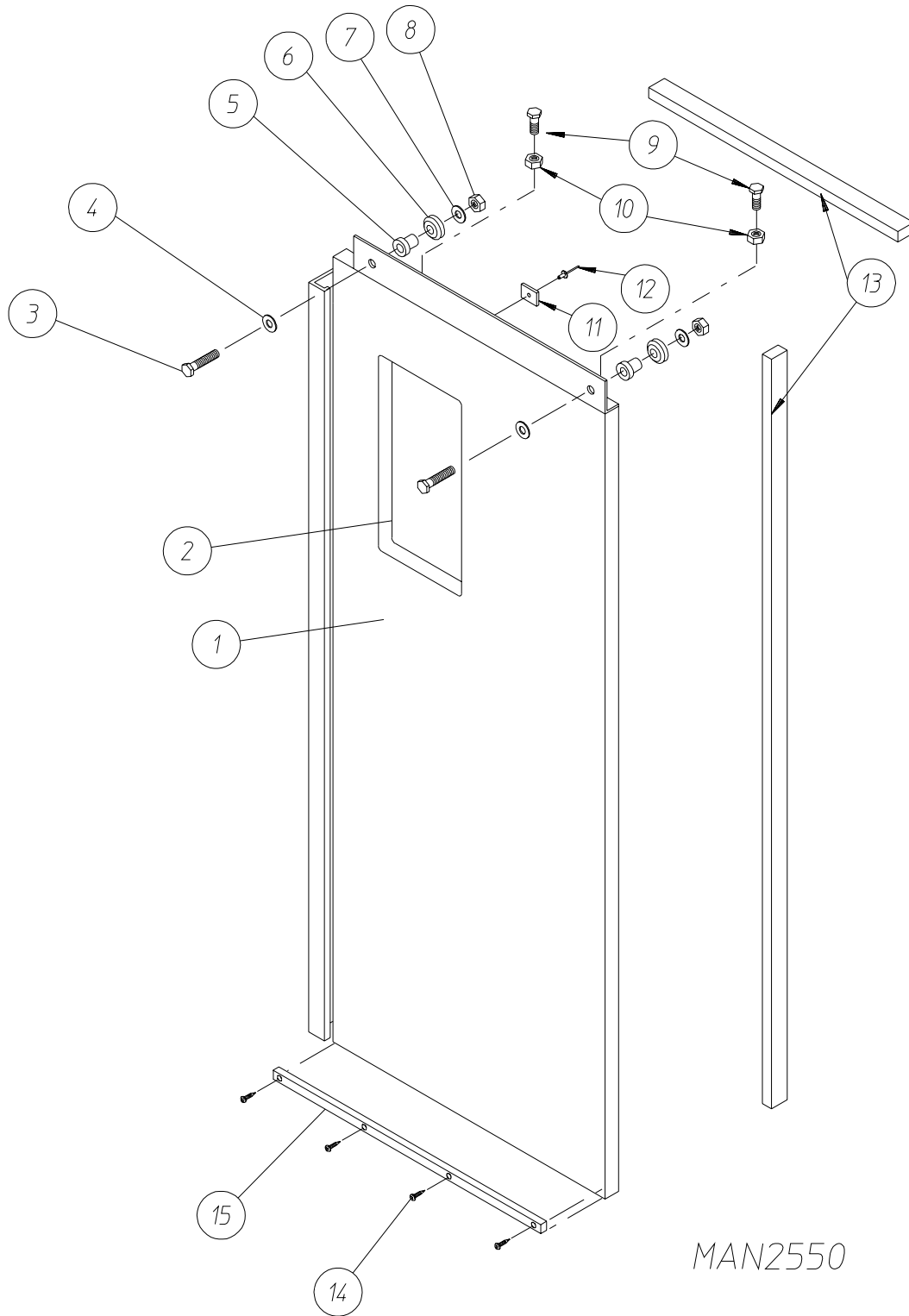

MAN2550

MANUAL DOOR

<u>Illus. No.</u>	<u>Part No.</u>	<u>Qty.</u>	<u>Description</u>
1*	821727	1	Right Manual Load Door Assembly Complete (includes illus. nos. 1 through 15)
2	102215	1	Door Window
	170730	-	Door Window Adhesive (10.3 oz. cartridge)
3	150112	2	1/4-20 x 1-1/4" Hex Head Machine Screw
4	153018	2	1/4" Flat Washer
5	170367	2	Stainless Steel Stationary Bushing
6	170366	2	Stainless Steel Sealed Wheel
7	153007	2	1/4" Lock Washer
8	152002	2	1/4-20 Hex Nut
9	150512	2	1/4-20 x 1/2" Hex Head Machine Bolt
10	152002	2	1/4-20 Hex Nut
11	102102	1	Door Magnet
12	154200	1	5/32" Pop Rivet
13	115995	80	Felt Gasket (sold by the inch)
14	150301	4	#8-18 x 7/16" Phillips Pan Head TEK Screw
15	170357	1	Lower Door Slide

* Specify color when ordering.

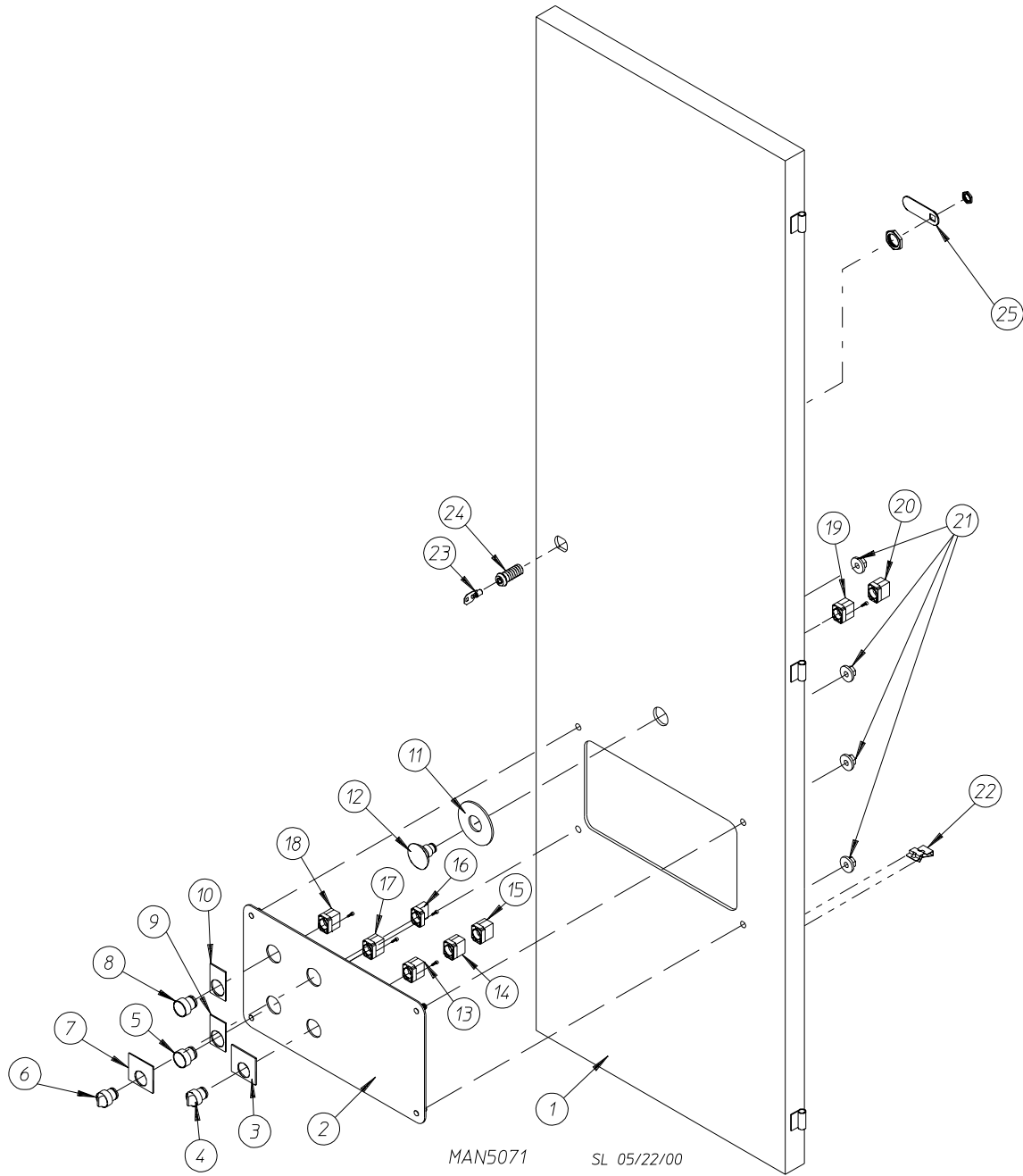

2 Door Models ONLY

<u>Illus. No.</u>	<u>Part No.</u>	<u>Qty.</u>	<u>Description</u>
1	838012	1	Right Rear Control Door ONLY
2	-----	1	Right Rear Door Control Panel (refer to Right Rear/Front Control Panel on page 94)
3	122438	1	Load/Dry/Unload Nameplate
4	122361	1	3-Position Maintained Operator
5	123202	1	White Push Button Operator
6	122360	1	2-Position Maintained Operator
7	122413	1	Tilt Off Tilt On Nameplate
8	123203	1	Black Push Button Operator
9	122416	1	Nameplate "Reverse"
10	122415	1	Nameplate "Forward"
11	122419	1	"EMERGENCY STOP" Label
12	122351	1	"EMERGENCY STOP" Operator
13	132394	1	Mounting Base with Normally Open Contact Block
14	132386	1	Normally Open Contact Block
15	132387	2	Normally Closed Contact Block
16	132394	1	Mounting Base with Normally Open Contact Block
17	132396	1	Mounting Base with N.O. and N.C Contact Block
18	132396	1	Mounting Base with N.O. and N.C Contact Block
19	132395	1	Mounting Base with N.C Contact Block
20	132387	1	Normally Closed Contact Block
21	152014	4	1/4-20 with 3/4" Free Spin Wash Nut
22	121509	6	Tie Wrap Clips
23	160140	1	ACE® XX4451 Key ONLY
24	160050	1	ACE® Control Door Lock Less Key (keyed to # XX4451)
25	160014	1	Cam ONLY

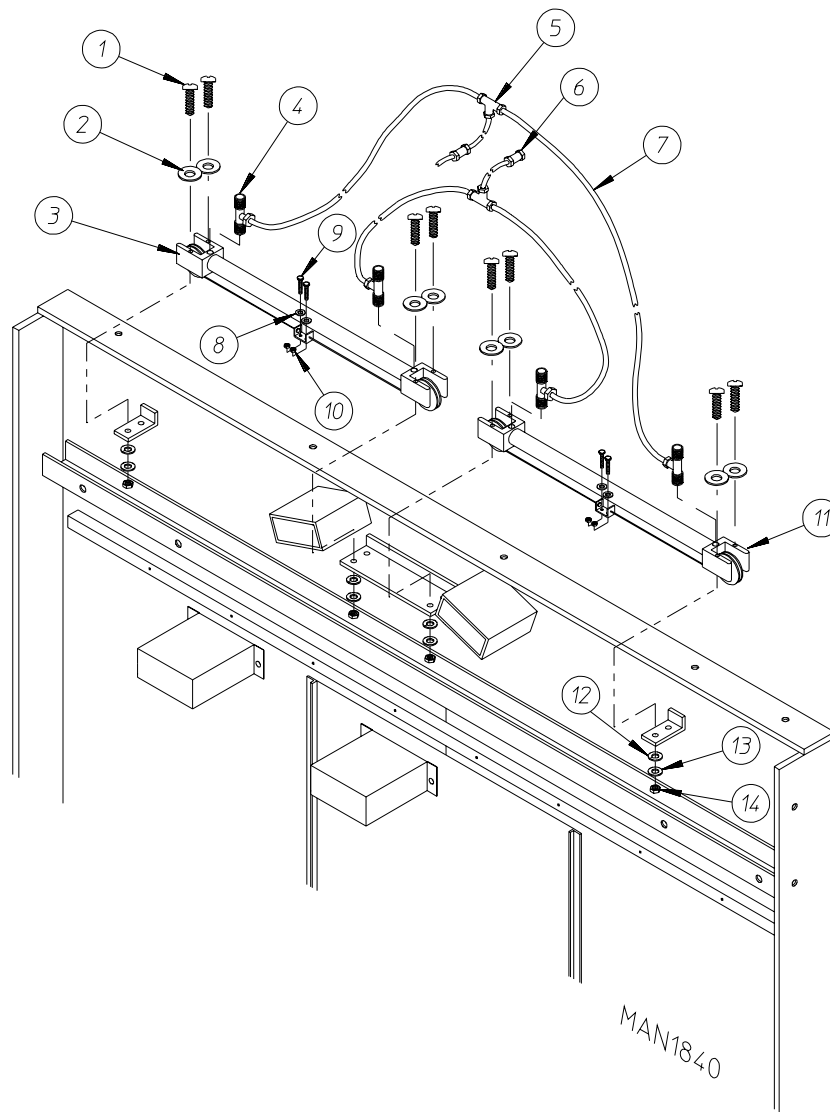

<u>Illus. No.</u>	<u>Part No.</u>	<u>Qty.</u>	<u>Description</u>
1	150308	8	#8-32 x 2-1/2" Phillips Pan Head Machine Screw
2	153000	8	#8 Flat Washer
3	100431	1	Cable Cylinder
4	128978	4	1/8" N.P.T x 1/4" Tube Flow Control
5	143156	2	1/4" Poly Tee
6	143154	2	1/4" Brass Poly Connector
7	143110	38	1/4" Poly-Flo Tubing (sold by the foot)
8	153012	4	#8 Star Washer
9	150103	4	#8-32 x 3/4" Phillips Round Head Machine Screw
10	152001	4	#8-32 Hex Nut
11	100431	1	Cable Cylinder
12	153000	8	#8 Flat Washer
13	153012	8	#8 Star Washer
14	152001	8	#8-32 Hex Nut

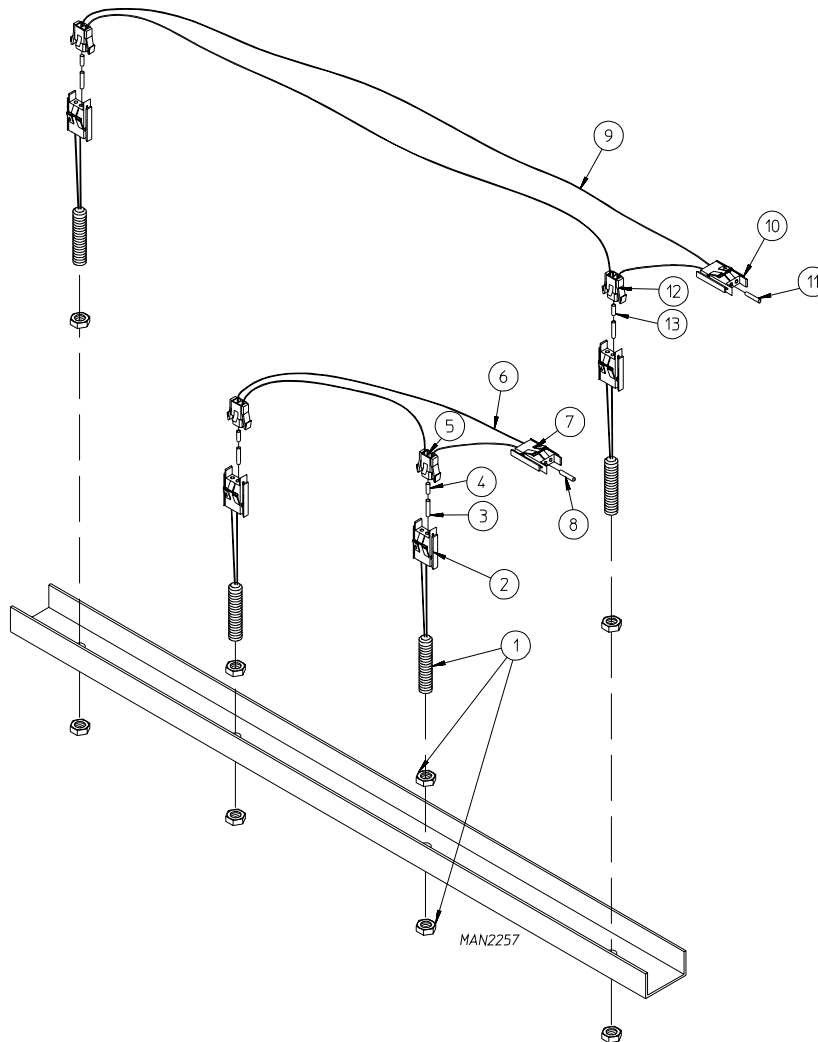

<u>Illus. No.</u>	<u>Part No.</u>	<u>Qty.</u>	<u>Description</u>
1	826514	4	Magnetic Door Switch Assembly with Nuts (includes illus. nos. 1 through 3)
2	122598	1	2-Pin Connector (male)
3	137028	2	Pin
4	137021	4	Microprocessor Socket
5	122599	2	2-Pin Socket Connector (female)
6	881240	1	Door Switch "Closed Position" Harness (includes illus. nos. 4 through 8)
7	122598	1	2-Pin Connector (male)
8	137028	2	Pin
9	881241	1	Door Switch "Open Position" Harness (includes illus. nos. 9 through 13)
10	122598	1	2-Pin Connector (male)
11	137028	2	Pin
12	122599	2	2-Pin Socket Connector (female)
13	137021	4	Microprocessor Socket

Left Hand Electrical Control Panel Assembly
For Models Mfd. with Thermal-Magnetic Protection ONLY

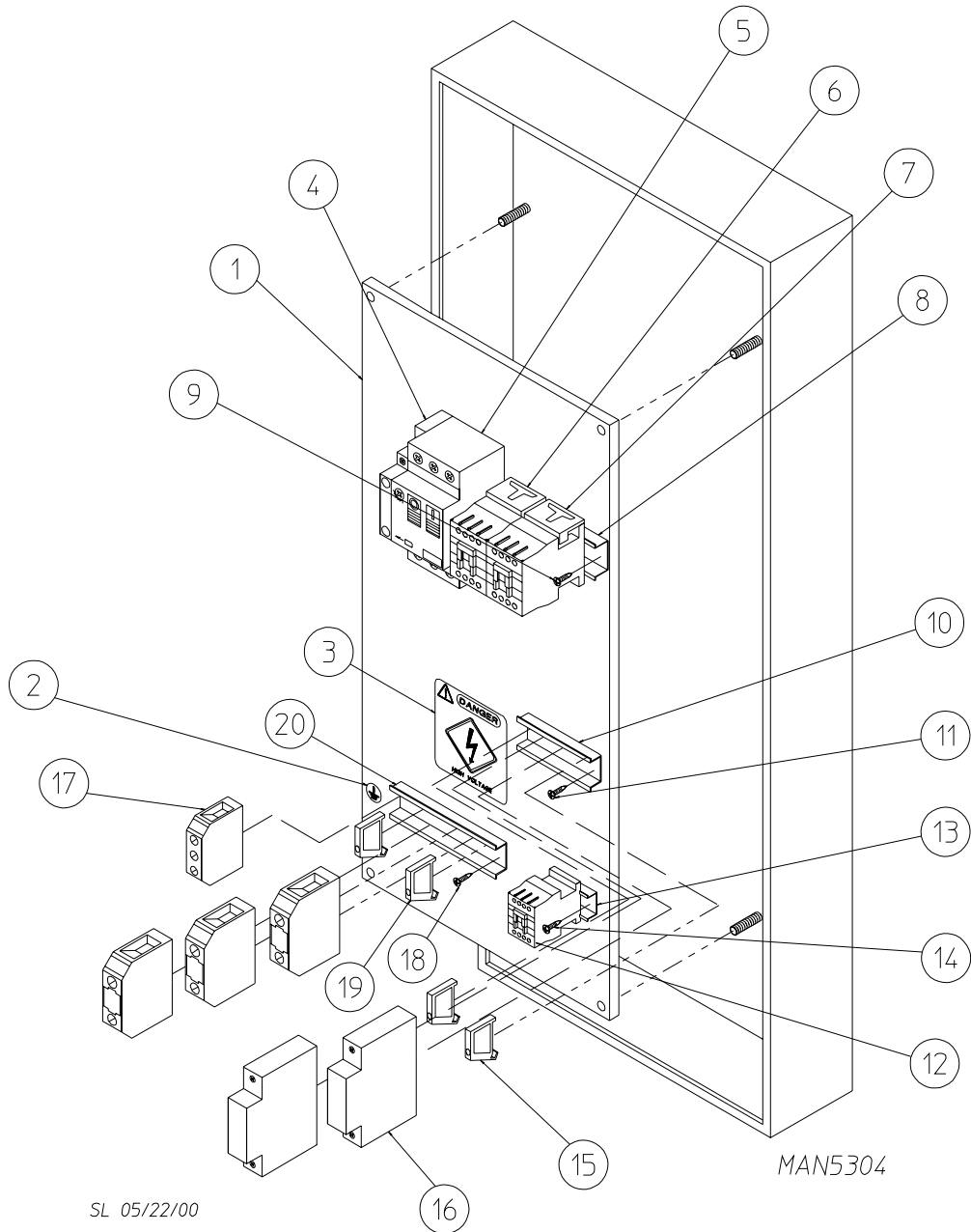

For Models Mfd. with Thermal-Magnetic Protection ONLY

<u>Illus. No.</u>	<u>Part No.</u>	<u>Qty.</u>	<u>Description</u>
1	334269	1	Left Hand Electrical Panel
	832948	1	Left Hand Electrical Panel Assembly Complete (includes illus. nos. 1 through 20)
2	112075	1	Ground Label
3	114007	1	Danger High Voltage Label
4	132389	1	Auxiliary Contact Block
5	131962	1	208/240v Thermal Magnetic Starter
	131961	1	380/480v Thermal Magnetic Starter
	131968	1	416/575v Thermal Magnetic Starter
6	132437	2	Varistor
7	132434	1	Reversing Contactor
8	120768	8	35 x 15mm Din Mounting Rail
9	150300	2	#10-16 x 1/2" Hex Washer TEK Screw
10	120768	3	35 x 15mm Din Mounting Rail
11	150300	2	#10-16 x 1/2" Hex Washer TEK Screw
12	132444	1	Sprinkler Contactor (for Dryer with Sprinkler Option Only)
13	120768	2	35 x 15mm Din Mounting Rail
14	150300	2	#10-16 x 1/2" Hex Washer TEK Screw
15	120765	2	End Stops
16	135506	1	208/240v Circuit Breaker (Steam Only)
	135514	1	208-480v Gas and 380-480v Steam Circuit Breaker
	135509	1	575v Circuit Breaker ONLY
17	120727	1	Ground Terminal Block
18	150300	1	#10-16 x 1/2" Hex Washer TEK Screw
19	120770	2	End Bracket 12mm
20	120768	4	35mm x 15mm Din Mounting Rail

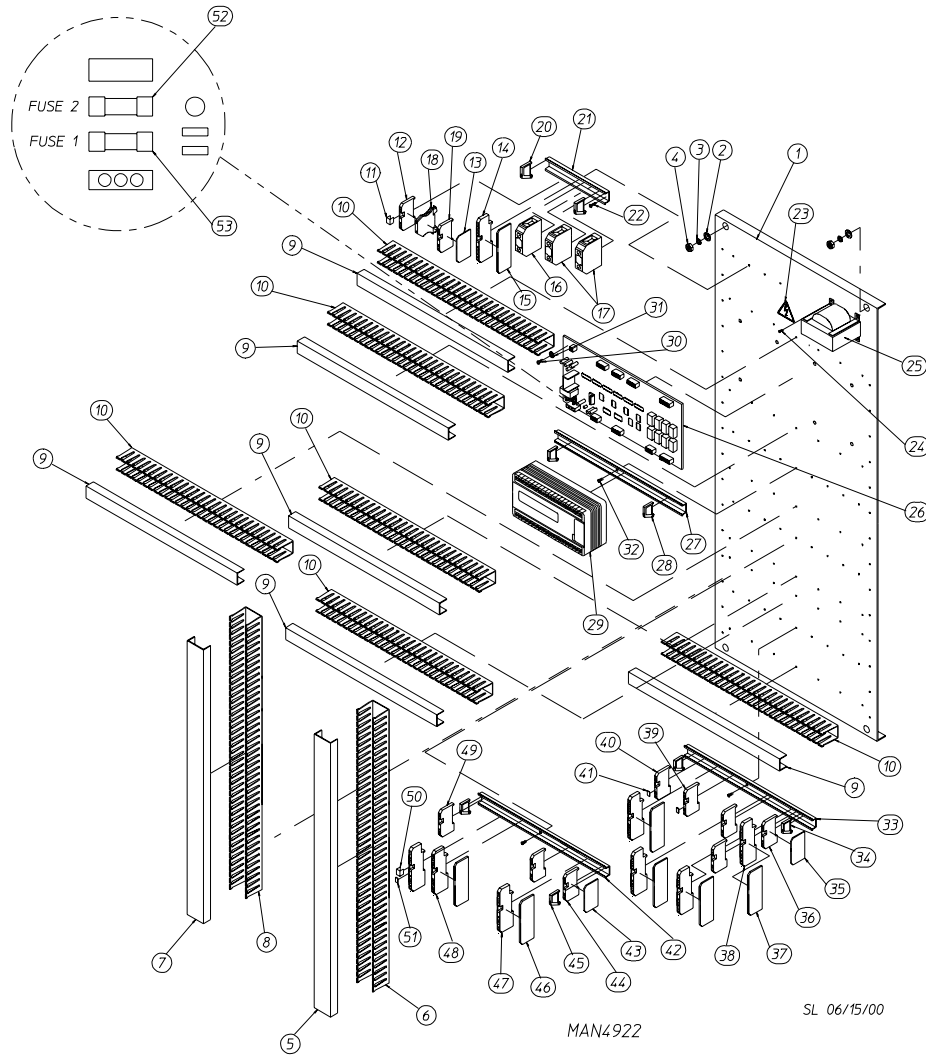

<u>Illus. No.</u>	<u>Part No.</u>	<u>Qty.</u>	<u>Description</u>
1	821833	1	Front Right Electrical Panel ONLY
2	150334	4	3/8" Flat Washer
3	153005	4	3/8" Split Lock Washer
4	152005	4	3/8-16 Hex Nut
5	121422	28"	1" Wire Duct Cover
6	121430	28"	1" x 3" Slotted Wall Wire Duct
7	121422	31"	1" Wire Duct Cover
8	121430	31"	1" x 3" Slotted Wall Wire Duct
9	121422	12"	1" Wire Duct Cover
10	121430	12"	1" x 3" Slotted Wall Wire Duct
11	120777	10	2-Position Terminal Block Jumper
12	120771	4	2-Position Gray Line Block
13	120776	6	Small Insulator for 2-Position Block
14	120778	2	4-Positions Gray Line Block
15	120801	2	Large Insulator for 4-Position Block
16	-----	1	Circuit Breaker #7 (refer to Right Hand Electrical Component Chart on page 95)
17	-----	1	Circuit Breaker #6 (refer to Right Hand Electrical Component Chart on page 95)

<u>Illus. No.</u>	<u>Part No.</u>	<u>Qty.</u>	<u>Description</u>
18	120773	3	2-Position Green/Yellow Ground Block
19	120772	2	2-Position Blue Neutral Block
20	120765	2	End Stop
21	120768	6	35 x 15mm Din Mounting Rail
22	150300	3	10-16 x 1/2" Hex Washer TEK Screw
23	122424	1	Power Warning Label
24	150300	4	#10-16 x 1/2" Hex Washer TEK Screw
25	-----	1	Transformer Assembly (refer to Right Hand Electrical Component Chart on <u>page 95</u>)
26	137246	1	Phase 7 Input/Output Board
27	120768	28	35 x 15mm Din Mounting Rail
28	120765	2	End Stop
29	137917	1	TSX07 PLC
30	150005	4	#6-32 x 1/4" Phillips Round Head Machine Screw
31	153010	4	#6 Star Washer
32	150300	4	#10-16 x 1/2" Hex Washer TEK Screw
33	120768	12"	35 x 15mm Din Mounting Rail
34	120765	2	End Stop
35	120776	1	Small Insulator for 2-Position Block
36	120771	21	2-Position Gray Line Block
37	120801	4	Large Insulator for 4-Position Block
38	120778	13	4-Position Gray Line Block
39	120773	3	2-Position Green/Yellow Ground Block
40	120772	1	2-Position Blue Neutral Block
41	401024	4	Marking Tags
42	120768	12"	35 x 15mm Din Mounting Rail
43	120776	1	Small Insulator for 2-Position Block
44	120773	1	2-Position Green/Yellow Ground Block
45	120765	2	End Stops
46	120801	7	Large Insulator for 4-Position Terminal Block
47	120778	32	4-Position Gray Line Block
48	120779	3	4-Position Blue Neutral Block
49	120771	9	2-Position Gray Line Block
50	120805	10	4-Position Terminal Block Jumper
51	401024	4	Marking Tags
52	136109	1	2-Amp 250v (fast acting) Fuse
53	136016	1	5-Amp 250v (fast acting) Fuse

Base Main Electrical Junction Box Assembly
For Models Mfd. with Thermal-Magnetic Protection ONLY

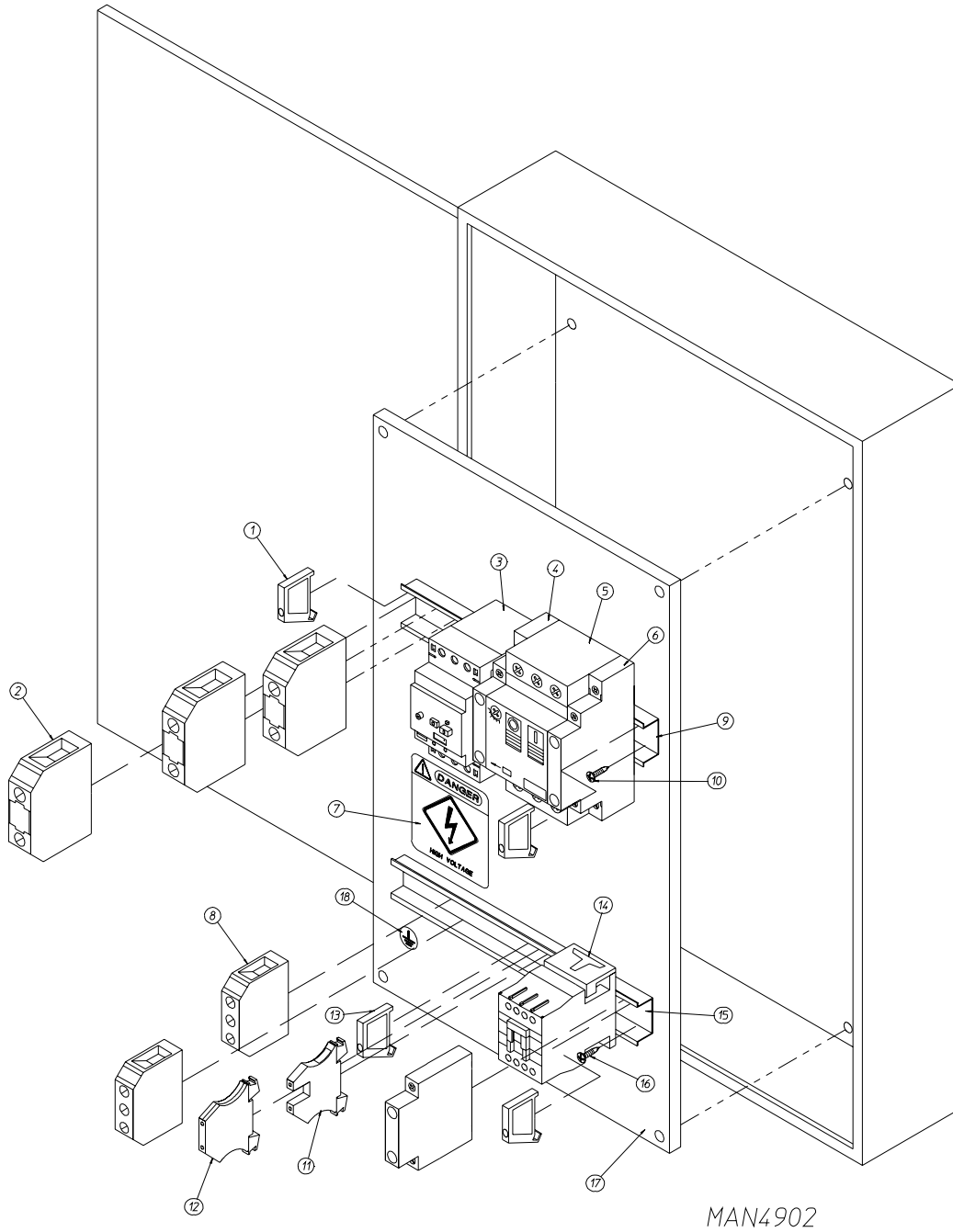

SL 03/13/00

For Models Mfd. with Thermal-Magnetic Protection ONLY

<u>Illus. No.</u>	<u>Part No.</u>	<u>Qty.</u>	<u>Description</u>
1	120770	2	End Bracket
2	120760	3	Terminal Block
3	131957	1	Circuit Breaker #4 (25-40 amp manual starter)
4	132384	1	208/240v Steam ONLY Auxiliary Contact Block
	132389	1	ALL Gas and 380-575v Steam Auxiliary Contact Block
5	131969	1	208/240v Gas Circuit Breaker (20-25 amp manual starter)
	131970	1	380-575v Gas Circuit Breaker (9-14 amp manual starter)
	131955	1	208v Steam Circuit Breaker (40-63 amp manual starter)
	131957	1	240v Steam Circuit Breaker (25-40 amp manual starter)
	131964	1	380/460/480v Steam Circuit Breaker (17-23 amp manual starter)
	131969	1	400/416 Steam Circuit Breaker (20-25 amp manual starter)
	131963	1	575v Steam Circuit Breaker (13-18 amp manual starter)
6	132384	1	208/240v Steam ONLY Auxiliary Contact Block
	132389	1	ALL Gas and 380-575v Steam Auxiliary Contact Block
7	114007	1	Danger High Voltage Label
8	120727	2	Ground Terminal Blocks
9	120768	8	35 x 15mm Din Mounting Rail
10	150300	4	#10 x 1/2" Hex Washer TEK Screw
11	120750	1	Ground Terminal Block (for sprinkler option)
12	120758	2	2-Position Feed Thru Terminal Block (for sprinkler option)
13	120765	2	Standard End Stop
14	132465	1	208/240v Gas 380/480 Volt Steam Drive Contactor
	132445	1	380-575v Gas Drive Contactor
	132480	1	208v Steam Drive Contactor
	132481	1	230/240v Steam Drive Contactor
	132433	1	575v Steam Drive Contactor
15	120768	8	35 x 15mm Din Mounting Rail
16	150300	4	#10 x 1/2" Hex Washer TEK Screw
17	331499	1	Panel ONLY
18	112075	1	Ground Here Label

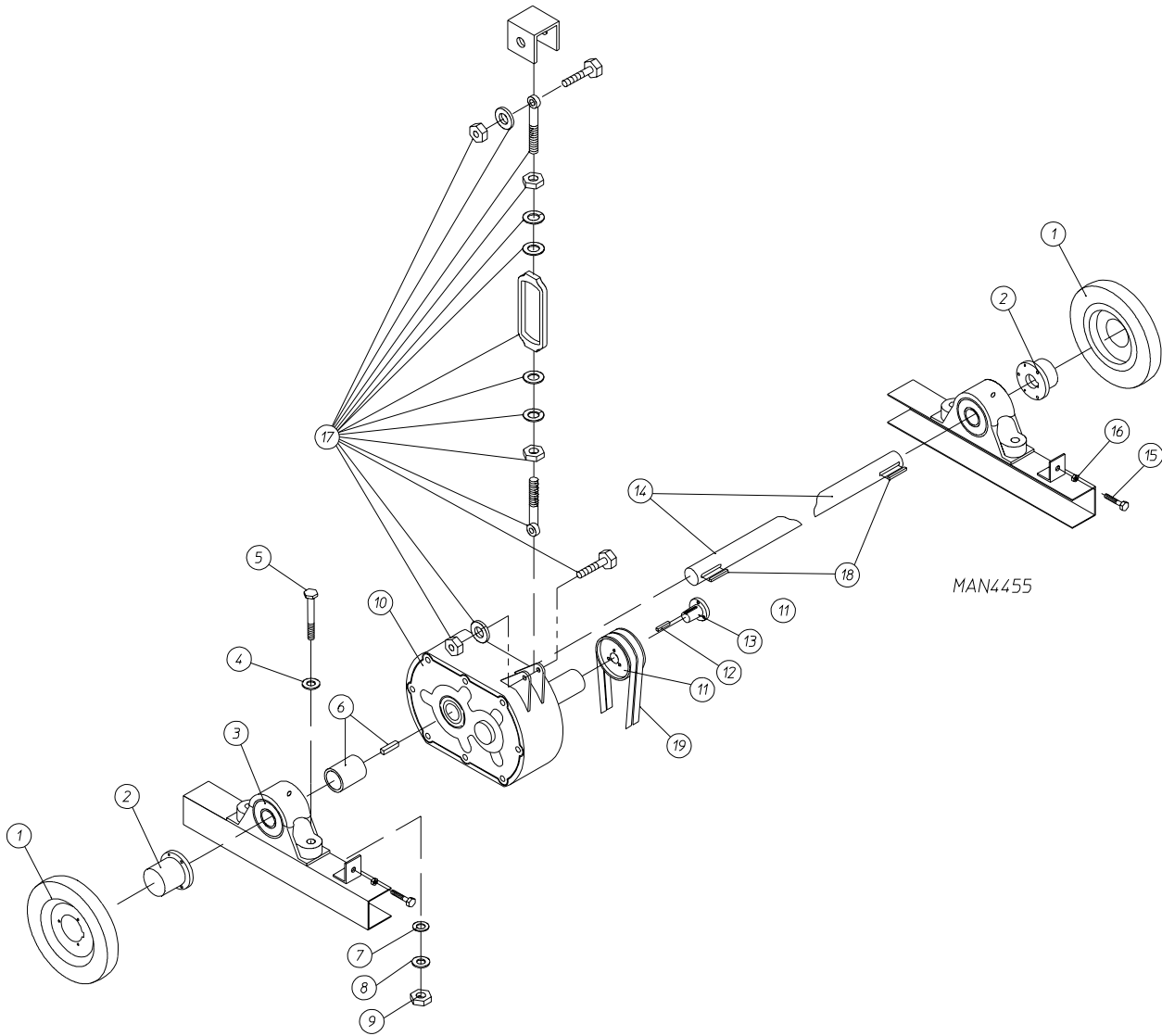

<u>Illus. No.</u>	<u>Part No.</u>	<u>Qty.</u>	<u>Description</u>
1	821465	2	11" Drive Wheel Assembly
2	101227	2	SK x 1-1/2" Taper Lock Bushing
3	880880	2	1-1/2" Pillow Block Bearing with Grease Fitting
	170511	2	1/8-27 N.P.T. Grease Fitting
4	153011	4	9/16" Flat Washer
5	150620	4	1/2-13 x 2-1/2" Hex Head Machine Bolt
6	101023	1	1-1/2" Taper Bushing
7	153011	4	9/16" Flat Washer
8	153026	4	1/2" Lock Washer
9	152011	4	1/2-13 Hex Nut
10	101019	1	Taper Bore Speed Reducer
11	101177	1	2B x 5.8 Pulley
12	100709	1	3/8" x 3/8" x 2" Key
13	101196	1	SDS x 1-5/8" Bushing
14	332749	1	Tumbler Drive Shaft
15	150609	2	1/2-13 x 4-1/2" Hex Head Machine Bolt
16	152011	2	1/2-13 Hex Nut
17	154395	1	Gear Reducer Turnbuckle
18	100710	2	3/8" x 3/8" x 3" Key
19*	100152	1	AX-25 V-Belt (for 60 Hz models Only)
	100160	1	AP-26 V-Belt (for 50 Hz models Only)

* Replace in matched sets (both belts).

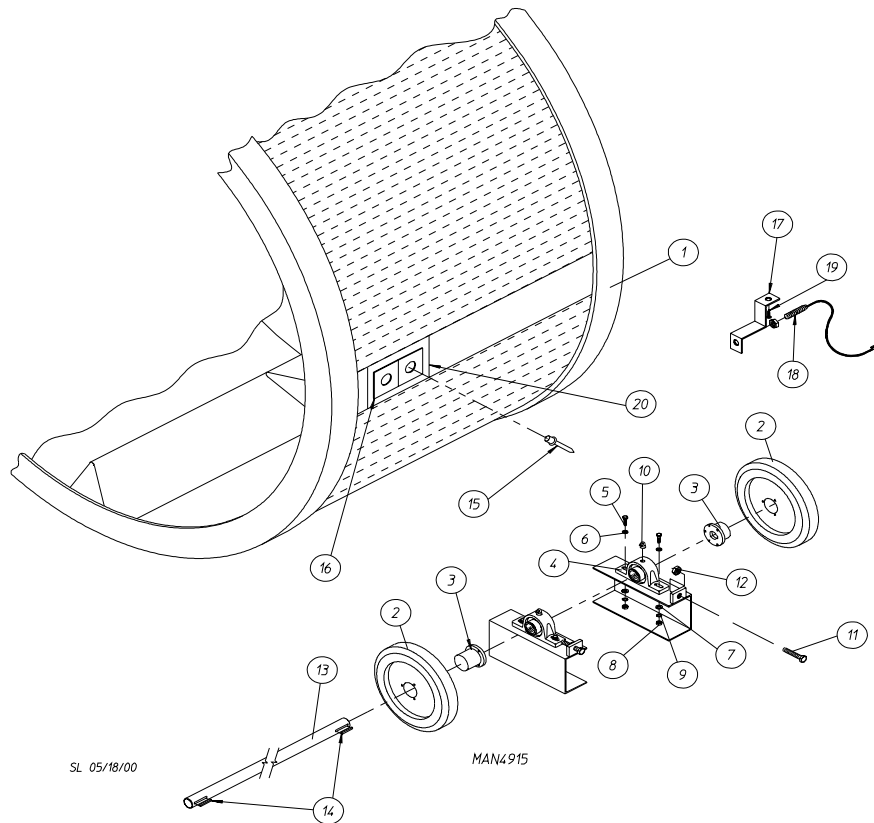

<u>Illus. No.</u>	<u>Part No.</u>	<u>Qty.</u>	<u>Description</u>
1	821217	1	Tumbler Assembly (for 1 door models)
	821645	1	Tumbler Assembly (for 2 door models)
2	821465	2	Drive Wheel Assembly
3	101227	2	SK x 1-1/2" Bushing
4	880880	2	1-1/2" Pillow Block Bearing with Set Screws and Grease Fitting
5	150620	4	1/2-13 x 2-1/2" Hex Head Machine Bolt
6	153016	4	1/2" Flat Washer
7	153016	4	1/2" Flat Washer
8	153026	4	1/2" Lock Washer
9	152011	4	1/2-13 Hex Nut
10	170511	2	1/8-27 N.P.T. Grease Fitting
11	150609	2	1/2-13 x 4-1/2" Hex Head Machine Bolt
12	152011	2	1/2-13 Hex Nut
13	332507	1	1-1/2" Diameter Idler Shaft
14	100710	2	3/8" x 3/8" x 3" Key
15	154200	2	5/32" Pop Rivet
16	102102	2	Magnet
17	333152	1	Phase 7 Rotational Sensor Bracket
18	882633	1	Rotational Sensor Proximity Switch
19	150309	1	10-16 x 1/2" Hex Head Crimpite TEK
20	333163	1	Magnet Plate for Rotational Sensor

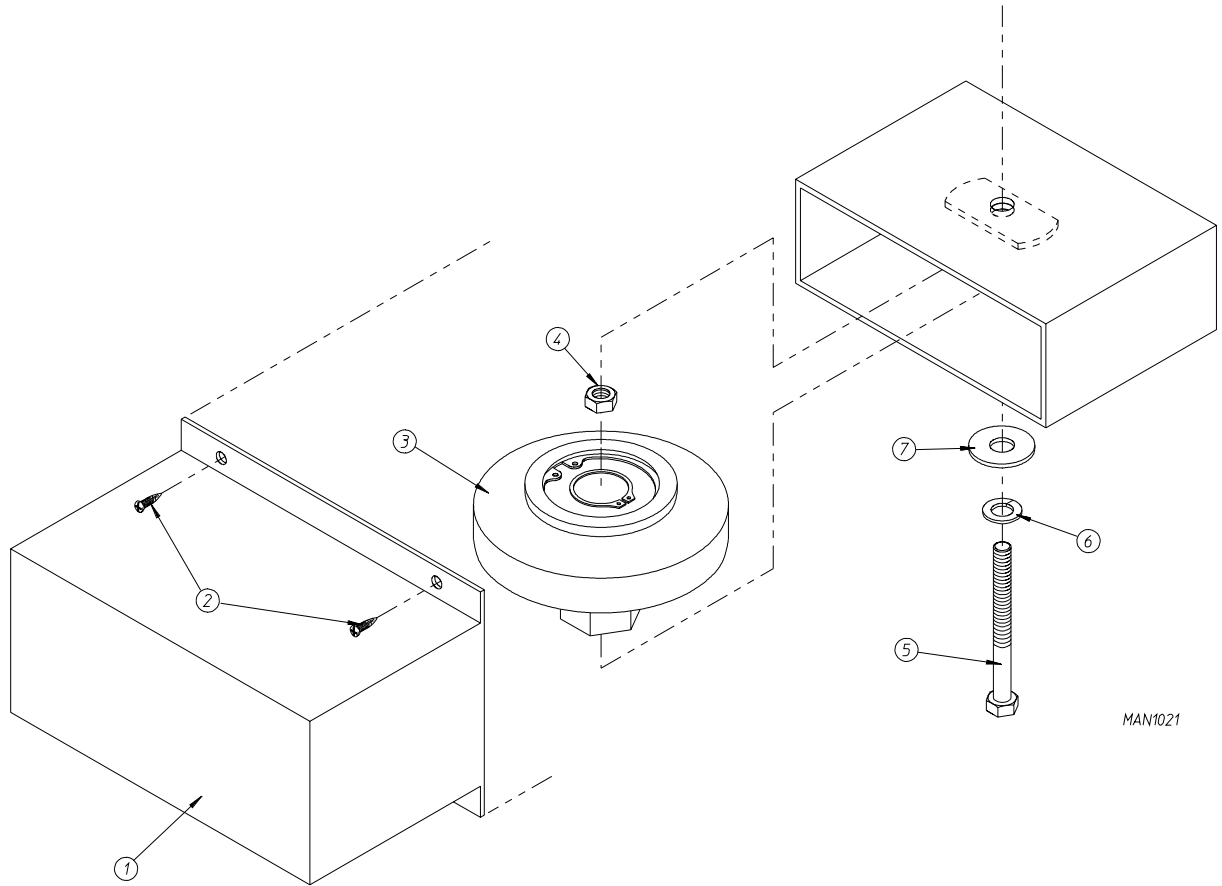

MAN1021

Illus. No.	Part No.	Qty.	Description
1*	-----	1	Tumbler Retaining Wheel Cover/Guard (refer to appropriate Front Panel Assembly or Rear Panel Assembly)
2	150301	4	#8-18 x 7/16" Phillips Pan Head TEK Screw
3	820566	1	Tumbler Retaining Wheel Assembly
4	152004	1	5/16-18 Hex Nut
5	150509	1	5/16-18 x 3" Hex Head Machine Bolt
6	153002	1	5/16" Lock Washer
7	153001	1	5/16" Flat Washer

* Specify color when ordering.

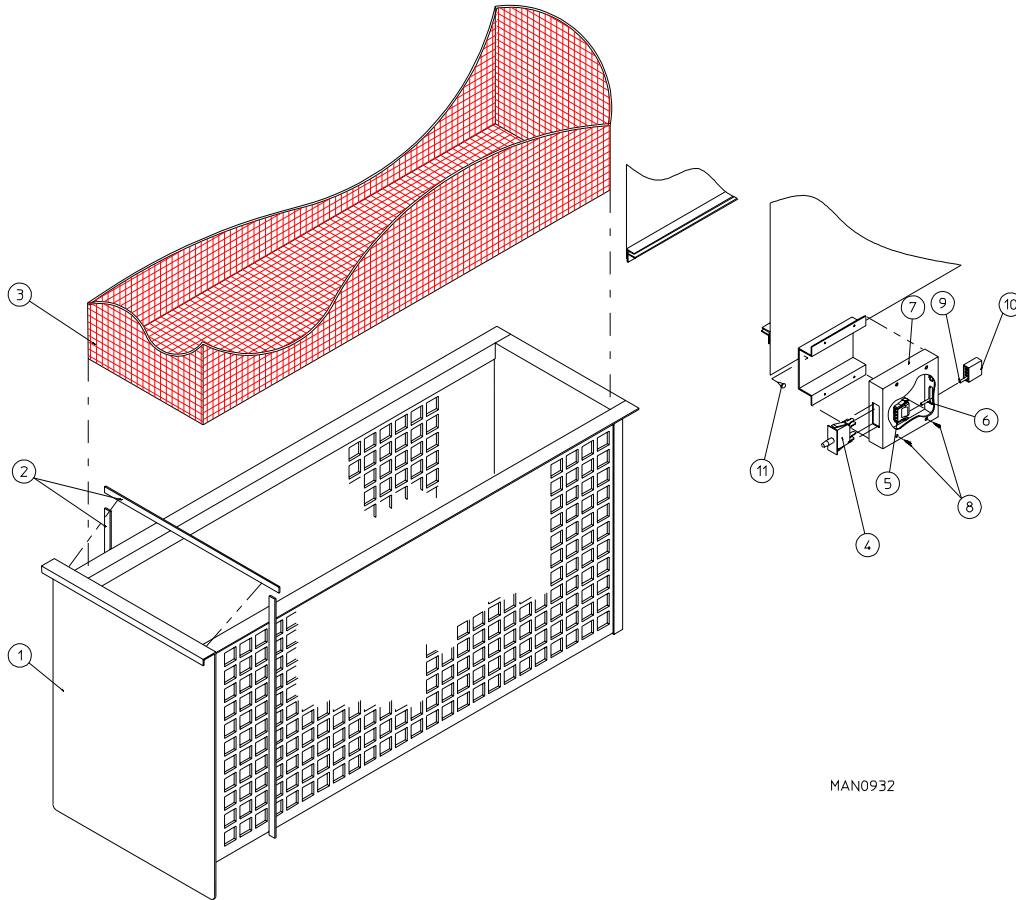

MAN0932

Illus. No.	Part No.	Qty.	Description
1*	880787	1	Lint Drawer/Basket Assembly Complete (includes illus. nos. 1 and 2) For Forward Tilt Models ONLY
	881185	1	Lint Drawer/Basket Assembly Complete (includes illus. nos. 1 and 2) For 2-Way Tilt and Rear Tilt Models ONLY
2	117602	7	Noise Suppressor Tape (sold by the foot)
3	821276	1	Lint Screen Assembly
4	122116	1	Lint Drawer/Basket Switch ONLY
5	122605	2	4-Pin Socket Connector ONLY
6	122701	4	Socket Terminal ONLY
	122801	1	Pin/Socket Extraction Tool
7	800264	1	Lint Drawer/Basket Switch Box Assembly Complete (includes illus. nos. 4 through 7)
	304034	1	Lint Drawer/Basket Switch Cover ONLY
8	150301	4	#8-18 x 7/16" Phillips Pan Head TEK Screw
9	122700	4	Pin Terminal ONLY
10	122604	2	4-Pin Connector ONLY
11	150301	2	#8-18 x 7/16" Phillips Pan Head TEK Screw

* Specify color when ordering.

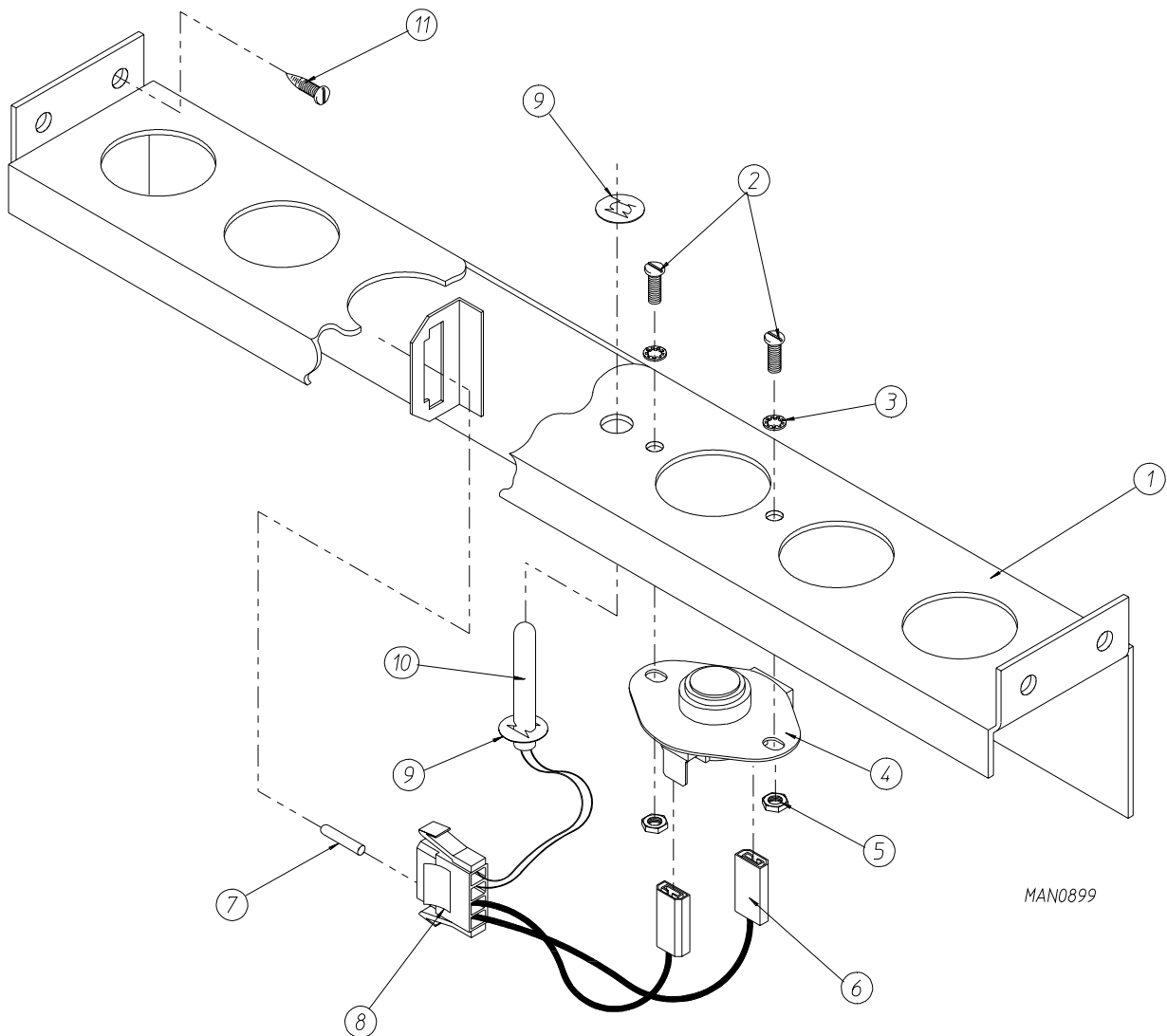

MAN0899

<u>Illus. No.</u>	<u>Part No.</u>	<u>Qty.</u>	<u>Description</u>
1	820967	1	Sensor Bracket Assembly
	820968	1	Sensor Bracket Assembly Complete (includes illus. nos. 1 through 10)
2	150000	2	#6-32 x 1/4" Slotted Round Head Machine Screw
3	153010	2	#6 Star Washer
4	130112	1	225° Thermostat ONLY
5	152000	2	#6-32 Hex Nut
6	121028	2	1/4" x .032 Insulated Terminal
7	122701	4	Socket Terminal ONLY
8	122605	1	4-Pin Socket Connector (female)
9	154007	2	1/4" Push On Fastener
10	880251	1	1/4" Temperature Sensor Probe Assembly (includes illus. nos. 6 through 10)
11	150301	4	#8-18 x 7/16" Phillips Pan Head TEK Screw

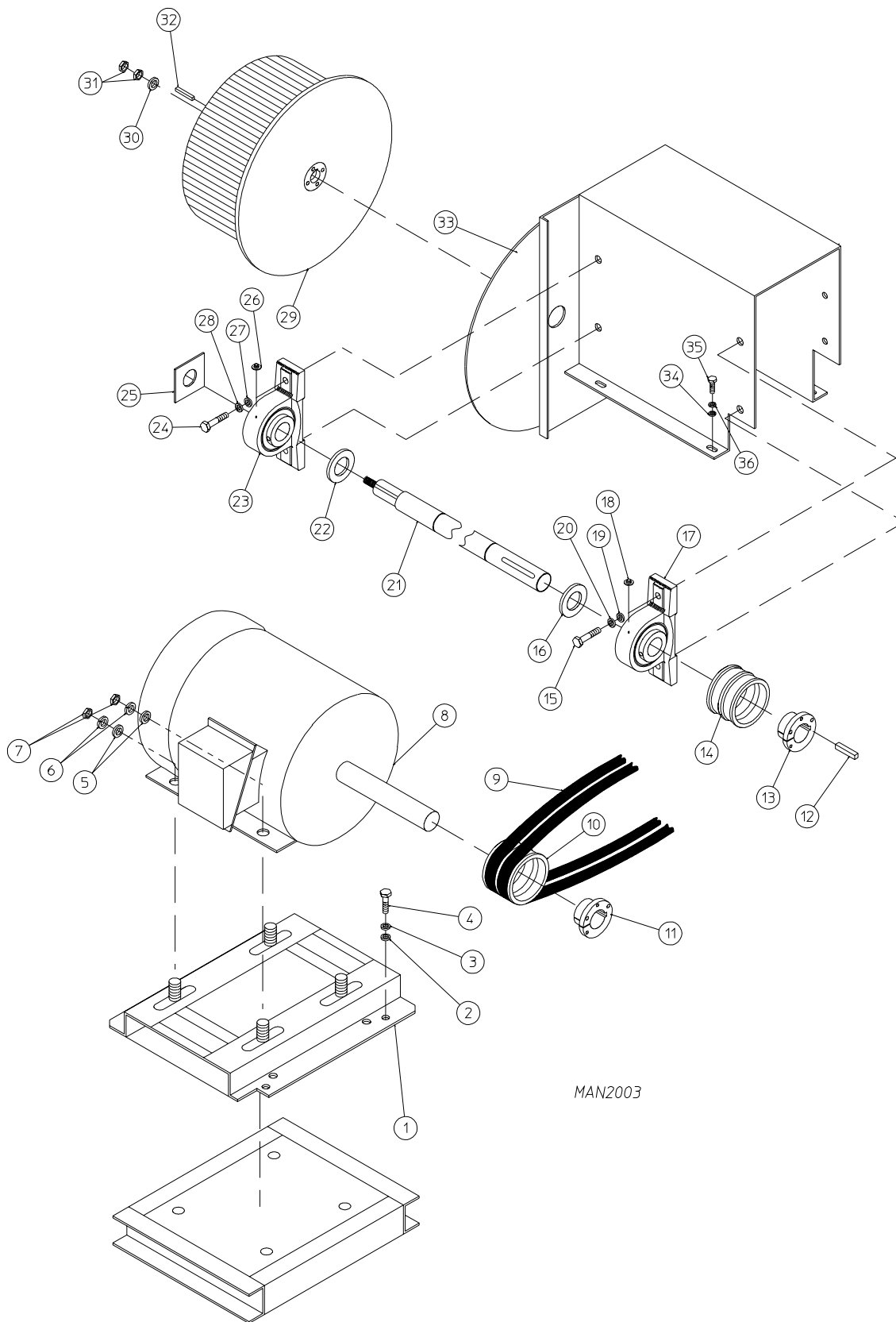

MAN2003

For Gas Models ONLY

<u>Illus. No.</u>	<u>Part No.</u>	<u>Qty.</u>	<u>Description</u>
1	100062	1	Motor Base 213T Frame
2	153004	4	3/8" Flat Washer
3	153005	4	3/8" Lock Washer
4	150617	4	3/8-16 x 1" Hex Head Machine Bolt
5	153004	4	3/8" Flat Washer
6	153005	4	3/8" Lock Washer
7	152005	4	3/8-16 Hex Nut
8	100046	1	7-1/2 HP 208-230/460v 3ø 60 Hz Motor
	100092	1	7-1/2 HP 190-220/380-416v 3ø 50 Hz Motor (for 50 Hz models Only) 380v 3ø 60 Hz Motor (for 60 Hz models Only)
	100021	1	7-1/2 HP 575v 3ø 60 Hz Motor
9*	100145	2	BX 32 V-Belt
10	101148	1	2B x 4.0 Pulley (for 60 Hz models Only)
	101147	1	2B x 4.8 Pulley (for 50 Hz models Only)
11	101152	1	SH x 1-3/8" Bushing (for 60 Hz models Only)
	101194	1	SDS x 1-3/8" Bushing (for 50 Hz models Only)
12	100706	1	5/16" x 5/16" x 1-3/8" Key
13	101152	1	SH x 1-3/8" Bushing
14	101195	1	2B x 4.4 Pulley
15	150600	2	3/8-16 x 1-1/2" Hex Head Machine Bolt
16	100802	1	1-3/8" Retaining Ring
17	880879	1	1-3/8" Shrouded Pillow Block Bearing (includes illus. nos. 17 and 18)
18	170511	1	Grease Fitting
19	153004	2	3/8" Flat Washer
20	153005	2	3/8" Lock Washer
21	332703	1	Fan Shaft
22	100802	1	1-3/8" Retaining Ring
23	880879	1	1-3/8" Shrouded Pillow Block Bearing (includes illus. nos. 23 and 26)
24	150600	2	3/8-16 x 1-1/2" Hex Head Machine Bolt
25	116014	1	Felt Seal
26	170511	1	Grease Fitting
27	153004	2	3/8" Flat Washer
28	153005	2	3/8" Lock Washer
29	100612	1	15" Squirrel Cage Fan
30	153065	1	Fan Washer
31	152006	2	1/2-20 Left Hand Jam Nut
32	100704	1	1/4" x 1/4" x 1-3/4" Key
33	881169	1	Tilt Fan Shaft Bearing Mount Assembly
34	153004	4	3/8" Flat Washer
35	150617	4	3/8-16 x 1" Hex Head Machine Bolt
36	153005	4	3/8" Lock Washer

* Replace belts in matched sets (both belts).

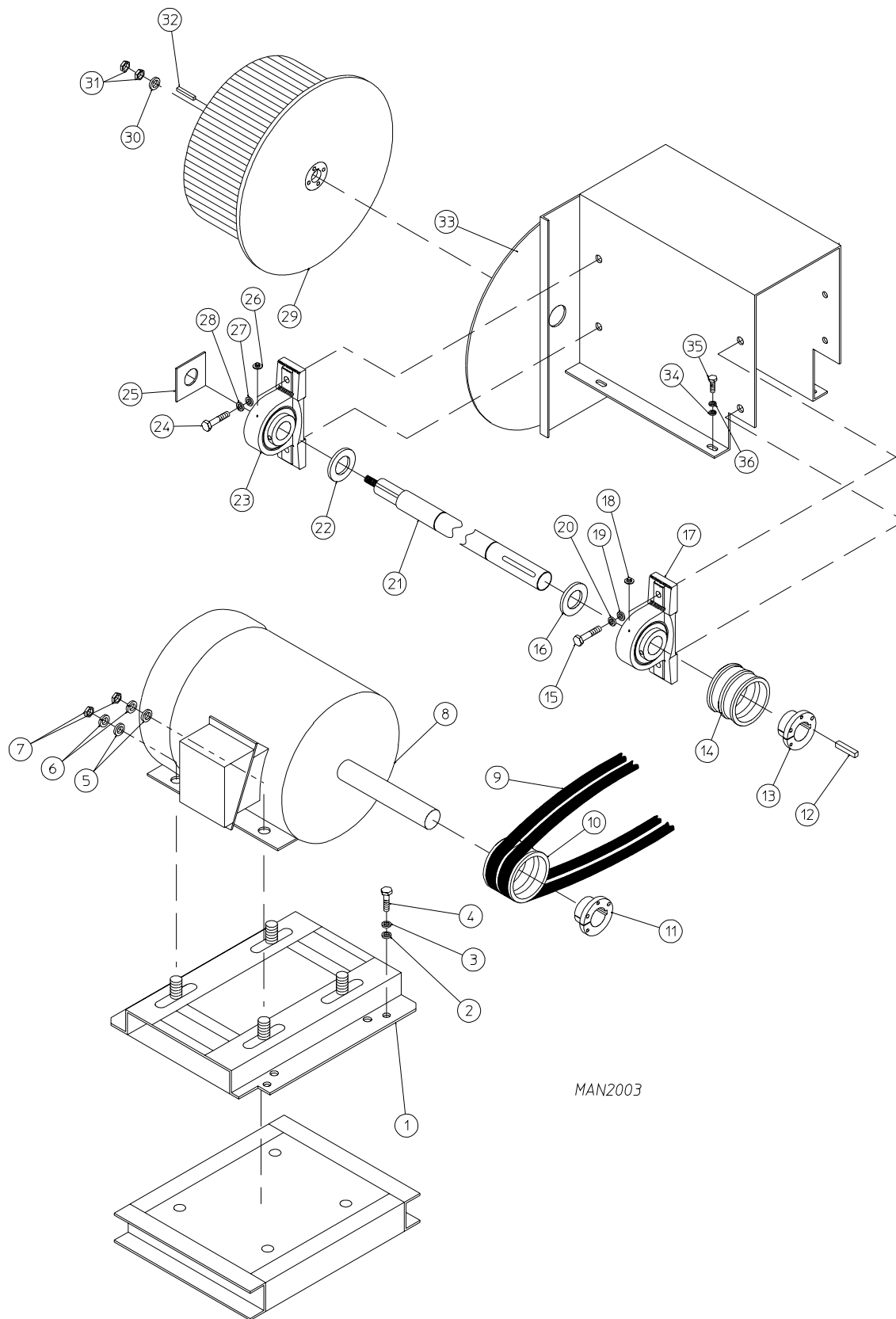

MAN2003

For Steam Models ONLY

<u>Illus. No.</u>	<u>Part No.</u>	<u>Qty.</u>	<u>Description</u>
1	100062	1	Motor Base 213T Frame
2	153004	4	3/8" Flat Washer
3	153005	4	3/8" Lock Washer
4	150617	4	3/8-16 x 1" Hex Head Machine Bolt
5	153004	4	3/8" Flat Washer
6	153005	4	3/8" Lock Washer
7	152005	4	3/8-16 Hex Nut
8	100087	1	15 HP 208-230/460v 3ø 60 Hz Motor (for 60 Hz models Only) 190-220/380-440v 3ø 50 Hz Motor (for 50 Hz models Only)
	100082	1	15 HP 380v 3ø 60 Hz Motor
	181001	1	15 HP 575v 3ø 60 Hz Motor
9*	100157	2	BX 36 V-Belt
10	101148	1	2B x 4.0 Pulley (for ALL 60 Hz models <i>except</i> 380 volt)
	101143	1	2B x 3.8 Pulley (for 380 volt - 60 Hz models Only)
	101195	1	2B x 4.4 Pulley (for 50 Hz models Only)
11	101152	1	SH x 1-3/8" Bushing
12	100706	1	5/16" x 5/16" x 1-3/8" Key
13	101194	1	SDS x 1-3/8" Bushing
14	101175	1	2B x 6.8 Pulley
15	150600	2	3/8-16 x 1-1/2" Hex Head Machine Bolt
16	100802	1	1-3/8" Retaining Ring
17	880879	1	1-3/8" Shrouded Pillow Block Bearing (includes illus. nos. 17 and 18)
18	170511	1	Grease Fitting
19	153004	2	3/8" Flat Washer
20	153005	2	3/8" Lock Washer
21	332703	1	Fan Shaft
22	100802	1	1-3/8" Retaining Ring
23	880879	1	1-3/8" Shrouded Pillow Block Bearing (includes illus. nos. 23 and 26)
24	150600	2	3/8-16 x 1-1/2" Hex Head Machine Bolt
25	116014	1	Felt Seal
26	170511	1	Grease Fitting
27	153004	2	3/8" Flat Washer
28	153005	2	3/8" Lock Washer
29	100612	1	15" Squirrel Cage Fan
30	153065	1	Fan Washer
31	152006	2	1/2-20 Left Hand Jam Nut
32	100704	1	1/4" x 1/4" x 1-3/4" Key
33	881169	1	Tilt Fan Shaft Bearing Mount Assembly
34	153004	4	3/8" Flat Washer
35	150617	4	3/8-16 x 1" Hex Head Machine Bolt
36	153005	4	3/8" Lock Washer

* Replace belts in matched sets (both belts).

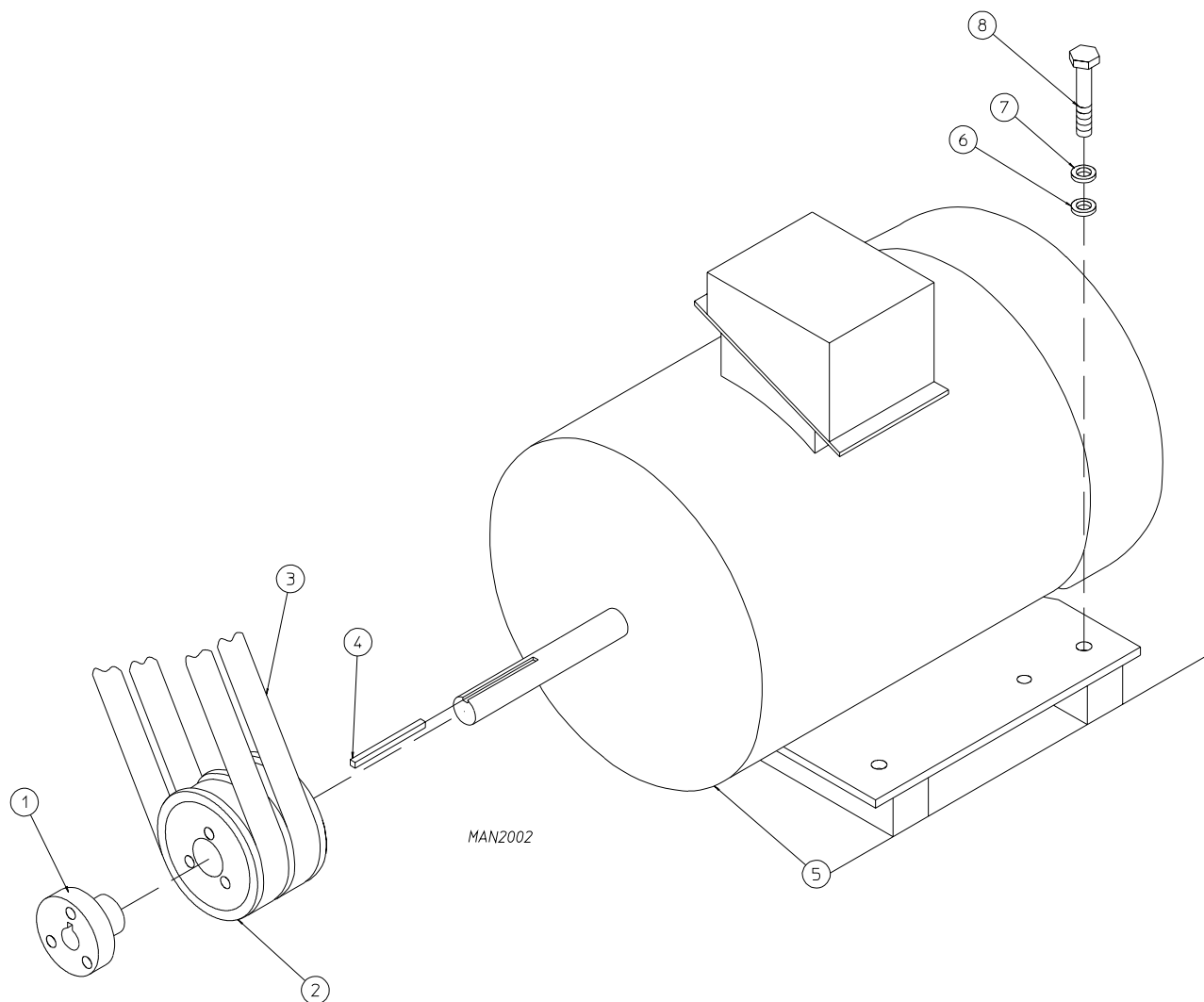

<u>Illus. No.</u>	<u>Part No.</u>	<u>Qty.</u>	<u>Description</u>
1	101198	1	SH x 7/8" Bushing
2	101187	1	2B x 3.6 Motor Pulley (for 60 Hz models Only)
	101195	1	2B x 4.4 Motor Pulley (for 50 Hz models Only)
3*	100152	2	AX-25 V-Belt (for 60 Hz models Only)
	100160	2	AX-26 V-Belt (for 50 Hz models Only)
4	100705	1	3/16" x 3/16" x 1-3/8" Key
5	100051	1	3 HP 208-230/460v 3ø 60 Hz Drive Motor (for 60 Hz models Only) 190-208/380-416v 3ø 50 Hz Drive Motor (for 50 Hz models Only)
	100022	1	3 HP 380v 3ø 60 Hz Drive Motor
	100088	1	3 HP 575v 3ø 60 Hz Drive Motor
6	153001	4	5/16" Flat Washer
7	153005	4	5/16" Lock Washer
8	150504	4	5/16-18 x 1" Hex Head Machine Bolt

* Replace belts in matched sets (both belts).

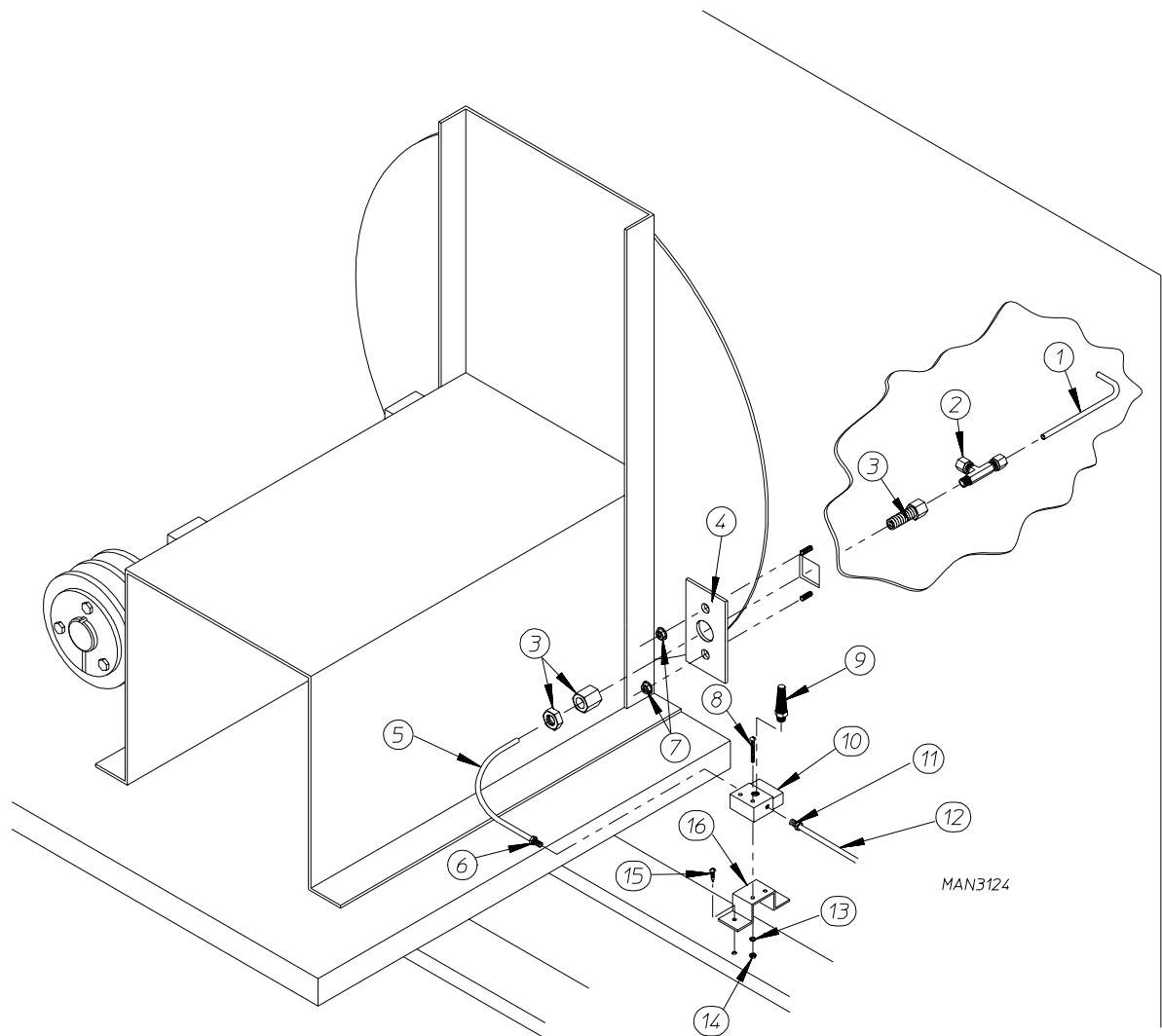

Illus. No.	Part No.	Qty.	Description
1	332700	1	Air Jet Tube
2	143287	1	1/4" x 1/8" M.P.T. Tee
3	143259	1	1/4" Compression x 1/8" F.P.T. Bulkhead Fitting
4	332531	1	Air Jet Mounting Plate
5	143100	1	1/4" Aluminum Tube (sold by the foot)
6	143152	1	1/4" Compression x 1/8" M.P.T. Connector
7	152014	2	1/4-20 Free Spin Nut
8	150002	1	#6-32 x 1" Phillips Round Head Machine Screw
9	100520	1	1/8" N.P.T. Silencer/Muffler
10	100498	1	3-Way Micro Valve
11	100472	1	1/4" Poly x 1/8" M.P.T. Connector
12	143110	10	1/4" Poly-Flo Tubing (sold by the foot)
13	153010	2	#6 Star Washer
14	152000	2	#6-32 Hex Nut
15	150415	2	#10-16 x 1/2" Phillips Round Head Crimpite Screw
16	330987	1	Micro Valve Support Bracket

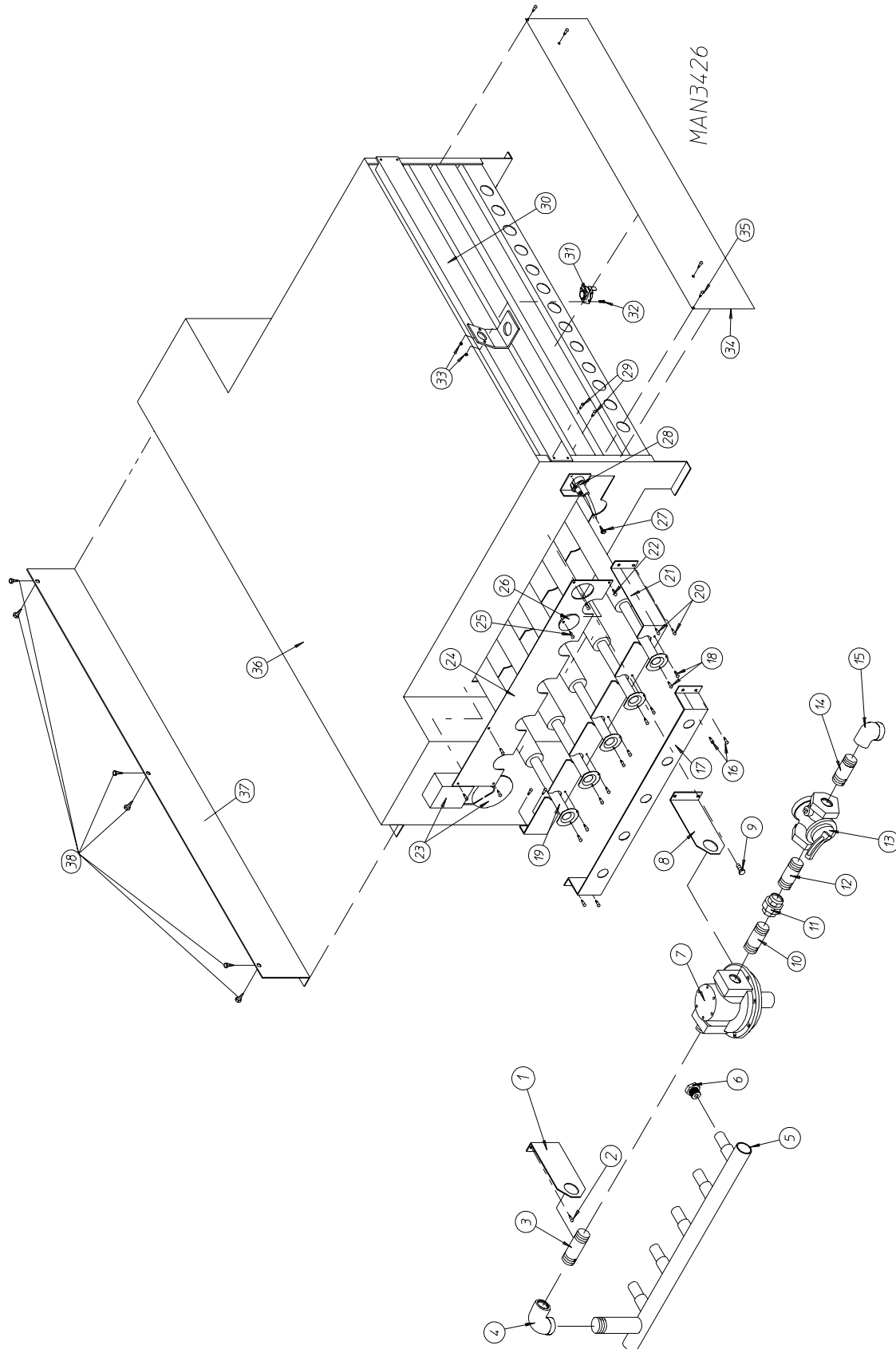

<u>Illus. No.</u>	<u>Part No.</u>	<u>Qty.</u>	<u>Description</u>
1	332604	1	Long Pipe Bracket
2	150301	2	#8-18 x 7/16" Phillips Pan Head TEK Screw
3	142724	1	1" x 2" Nipple
4	142548	1	1" x 90° Elbow
5	141243	1	5-Port Manifold
6*	140840	5	#1 Burner Orifice (for natural gas models)
	140821	5	#28 Burner Orifice (for liquid propane [L.P.] gas models)
7	140017	1	1" x 1" 24 VAC Gas Valve
	140018	1	1" x 24 VAC Gas Valve Conversion Kit
8	332604	1	Long Pipe Bracket
9	150301	2	#8-18 x 7/16" Phillips Pan Head TEK Screw
10	142724	1	1" x 2" Nipple
11	142602	1	1" Union
12	142724	1	1" x 2" Nipple
13	141302	1	1" Shut-Off Valve
14	142724	1	1" x 2" Nipple
15	142728	1	1" to 1-1/4" x 90° Reducing Elbow
16	150301	4	#8-18 x 7/16" Phillips Pan Head TEK Screw
17	332606	1	Manifold Rest
18	150301	10	#8-18 x 7/16" Phillips Pan Head TEK Screw
19	141110	5	Burner Tube
20	150301	4	#8-18 x 7/16" Phillips Pan Head TEK Screw
21	332607	1	Burner Tube Rest
22	150301	5	#8-18 x 7/16" Phillips Pan Head TEK Screw
23	-----	1	Sail Switch (refer to Sail Switch Assembly on page 58)
24	332597	1	Burner Box Cover Plate
25	150301	1	#8-18 x 7/16" Phillips Pan Head TEK Screw
26	331290	1	Sight Hole Disc
27	150415	2	#10-16 x 1/2" Phillips Round Head Crimptite Screw
28	880943	1	Direct Spark Ignition (DSI) Ignitor/Flame-Probe Assembly Kit
	880330	1	Direct Spark Ignition (DSI) Ignitor High Voltage (HV) Wire/Connector ONLY
	305410	1	Direct Spark Ignition (DSI) Gap Feeler Gauge
29	150415	4	#10-16 x 1/2" Phillips Round Head Crimptite Screw
30	881144	1	Hi-Limit Mounting Bracket
31	130401	1	330° Hi-Limit ONLY
32	150001	2	#6-32 x 1/2" Round Head Machine Screw
33	151000	2	#6-32 Pal Nut
34	332826	1	(Right Side) Ignition Baffle
35	150415	4	#10-16 x 1/2" Phillips Round Head Crimptite Screw
36	880789	1	Burner Box ONLY
	881145**	1	(Tilt) Natural Gas Burner Box Assembly Complete Less Orifices (includes illus. nos. 1 through 5 and 7 through 38)
	881146**	1	(Tilt) Liquid Propane (L.P.) Gas Burner Box Assembly Complete Less Orifices (includes illus. nos. 1 through 5 and 7 through 38)
--	880754*	1	Direct Spark Ignition (DSI) Liquid Propane (L.P.) Conversion Kit
37***	332622	1	(Left Side) Baffle/Cover
38***	150309	6	#10-16 x 1/2" Hex Head TEK Crimptite Screw

* Contact factory for elevations over 2,000 feet.

** Orifices are not included and **must be** ordered separately.

*** For use on models with Liquid Propane (L.P.) Gas ONLY.

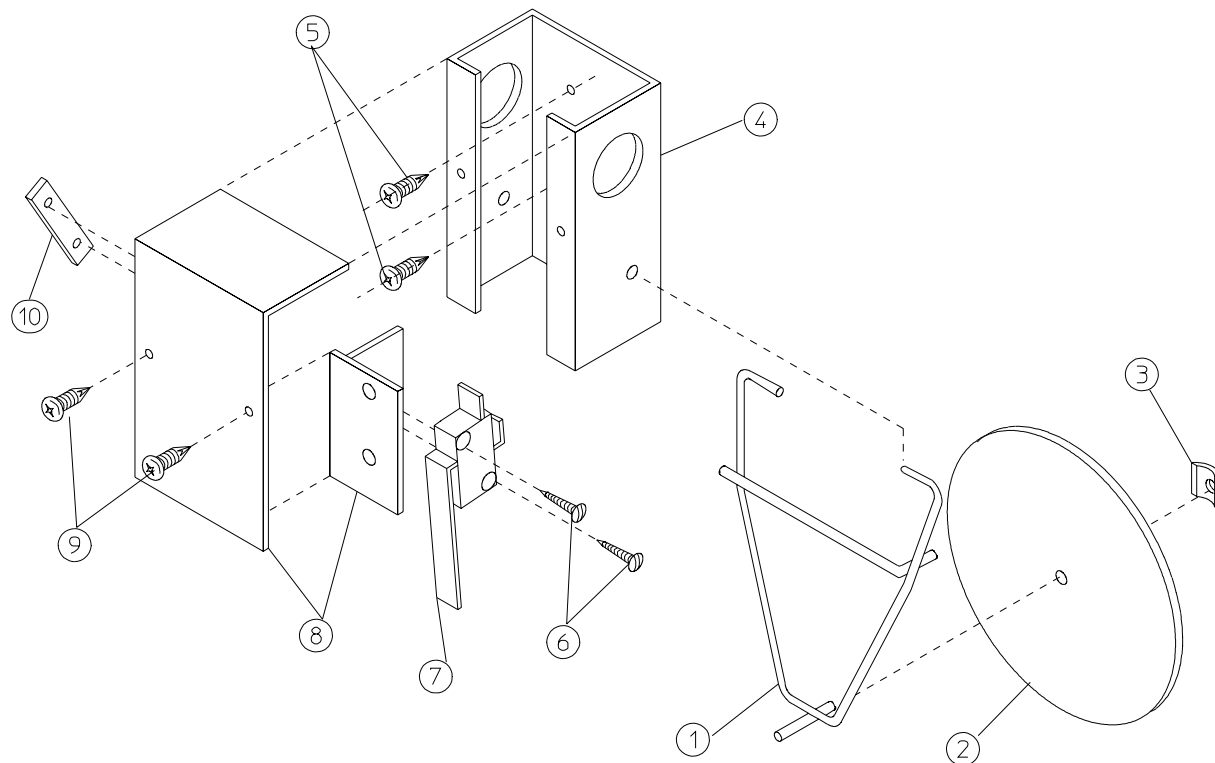

MAN0440

<u>Illus. No.</u>	<u>Part No.</u>	<u>Qty.</u>	<u>Description</u>
1	105500	1	Sail Switch Actuator Rod
2	332689	1	Sail Switch Damper (flat)
3	154002	1	1/8" Push On Fastener
4	802800	1	Sail Switch Box with Cover and Bracket ONLY (includes illus. nos. 4 and 8)
	880793	1	Sail Switch Box Assembly Complete (includes illus. nos. 1 through 4 and 6 through 10)
5	150300	2	#10 x 1/2" Hex Washer TEK Screw
6	150303	2	#4 x 3/4" Pan Head "A" Machine Screw
7	122200	1	Sail Switch ONLY
8	802799	1	Sail Switch Box Cover and Bracket ONLY
9	150415	2	#10-16 x 1/2" Phillips Round Head Crimptite Screw
10	154004	1	Twin Speed Nut

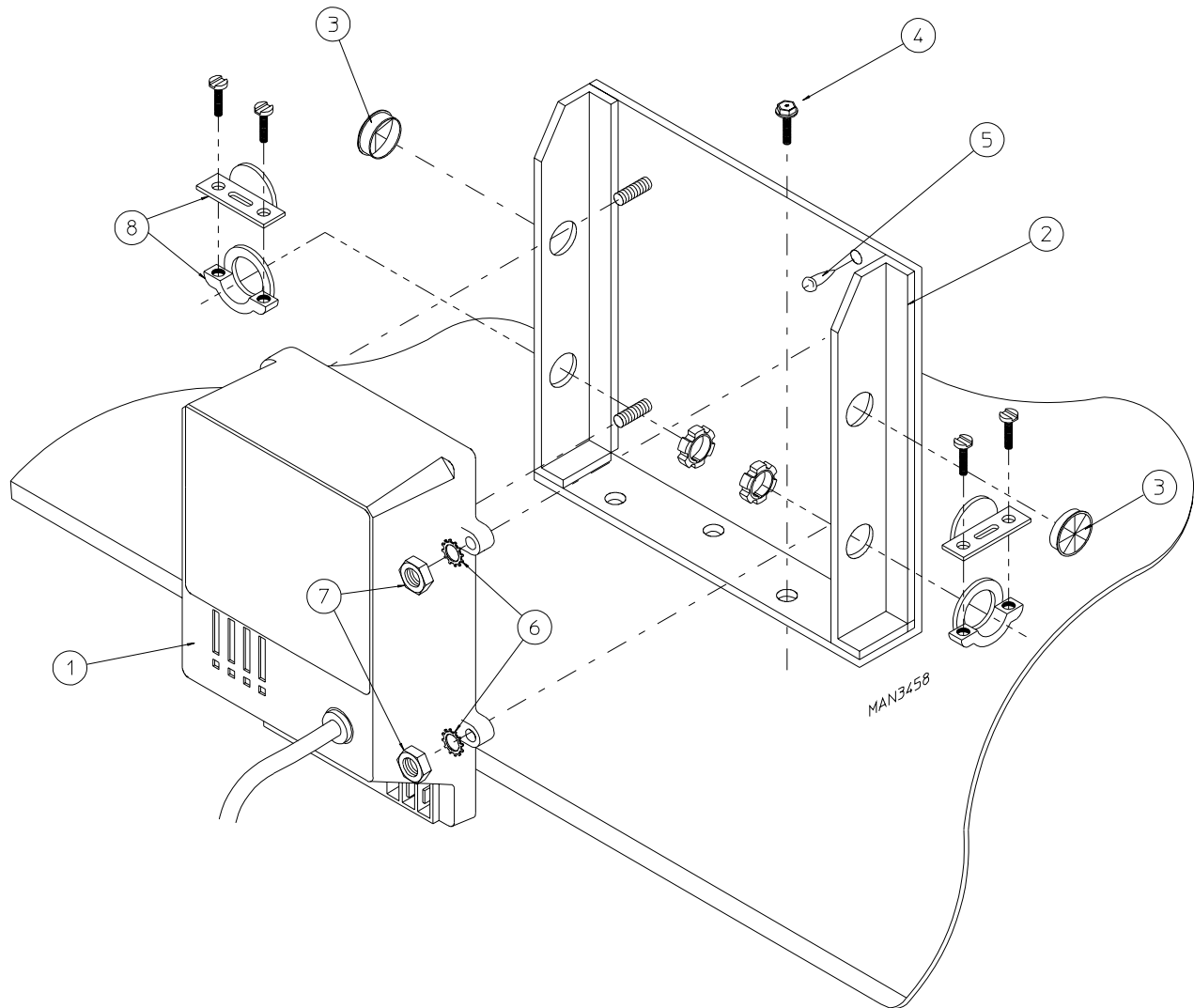

<u>Illus. No.</u>	<u>Part No.</u>	<u>Qty.</u>	<u>Description</u>
1	128935	1	Direct Spark Ignition (DSI) Module ONLY - 50/60 Hz For Models Mfd. as of April 1, 2000
	882627	1	Direct Spark Ignition (DSI) Module ONLY - 50/60 Hz For Models Mfd. prior to April 1, 2000
2	820100	1	Direct Spark Ignition (DSI) Module Mount Assembly ONLY
3	121400	2	Universal Bushing
4	150522	3	1/4-20 x 1/2" Hex Head TEK Screw
5	150301	1	#8-18 x 7/16" Phillips Pan Head TEK Screw
6	153010	4	#6 Star Washer
7	152000	4	#6-32 Hex Nut
8	120102	2	3/8" Straight x 1/2" Knock-Out Connector

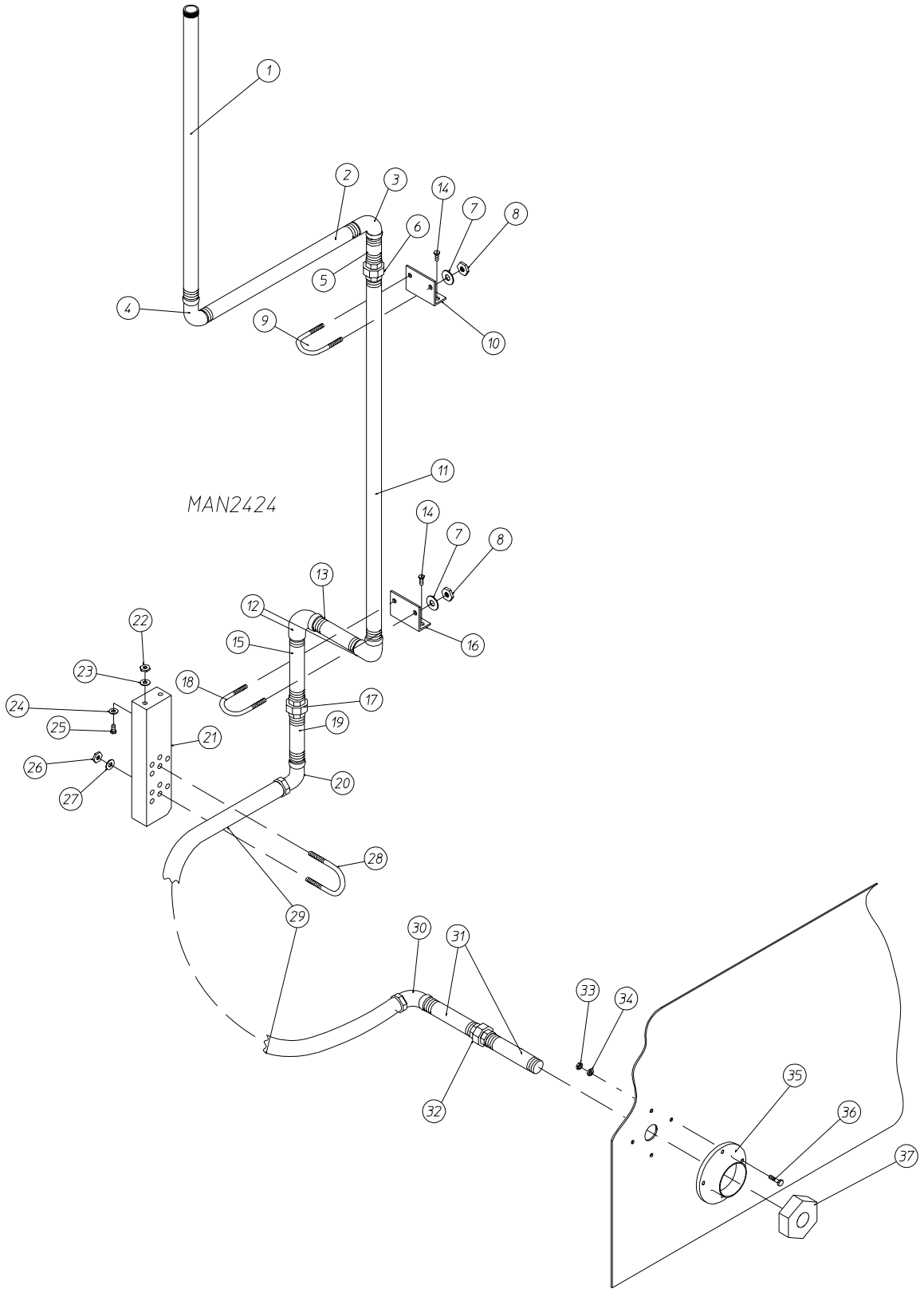

<u>Illus. No.</u>	<u>Part No.</u>	<u>Qty.</u>	<u>Description</u>
1	142726	1	1-1/4" x 24" Nipple
2	142555	1	1-1/4" x 15" Nipple
3	142554	1	1-1/4" 90° Elbow
4	142554	1	1-1/4" 90° Elbow
5	142725	1	1-1/4" x 2" Nipple
6	142558	1	1-1/4" Union
7	153002	4	5/16" Lock Washer
8	152004	4	5/16-18 Hex Nut
9	154353	1	1-1/4" Pipe U-Bolt
10	332781	1	Small Pipe Bracket
11	142610	1	1-1/4" x 32" Nipple
12	142554	2	1-1/4" 90° Elbow
13	142609	1	1-1/4" x 4-1/2" Nipple
14	150522	4	1/4-20 x 1/2" Hex Head TEK Screw
15	142564	1	1-1/4" x 5" Nipple
16	332781	1	Small Pipe Bracket
17	142558	1	1-1/4" Union
18	154353	1	1-1/4" Pipe U-Bolt
19	142725	1	1-1/4" x 2" Nipple
20	142554	1	1-1/4" 90° Elbow
21	333073	1	Flex Hose Bracket
22	152002	2	1/4-20 Hex Nut
23	153007	2	1/4" Lock Washer
24	153016	2	1/4" Flat Washer
25	150511	2	1/4-20 x 1" Hex Head Bolt
26	152004	2	5/16-18 Hex Nut
27	153002	2	5/16" Lock Washer
28	154351	1	1-1/2" Pipe U-Bolt
29	141416	1	1-1/4" x 48" Non-Swivel Flex Hose
30	142554	1	1-1/4" 90° Elbow
31	142727	2	1-1/4" x 4" Nipple
32	142558	1	1-1/4" Union
33	152004	4	5/16-18 Hex Nut
34	153002	4	5/16" Lock Washer
35	142514	1	2" Floor Flange
36	150504	4	5/16-18 x 1" Hex Head Machine Bolt
37	142513	1	2" x 1-1/4" Double Tapped Bushing

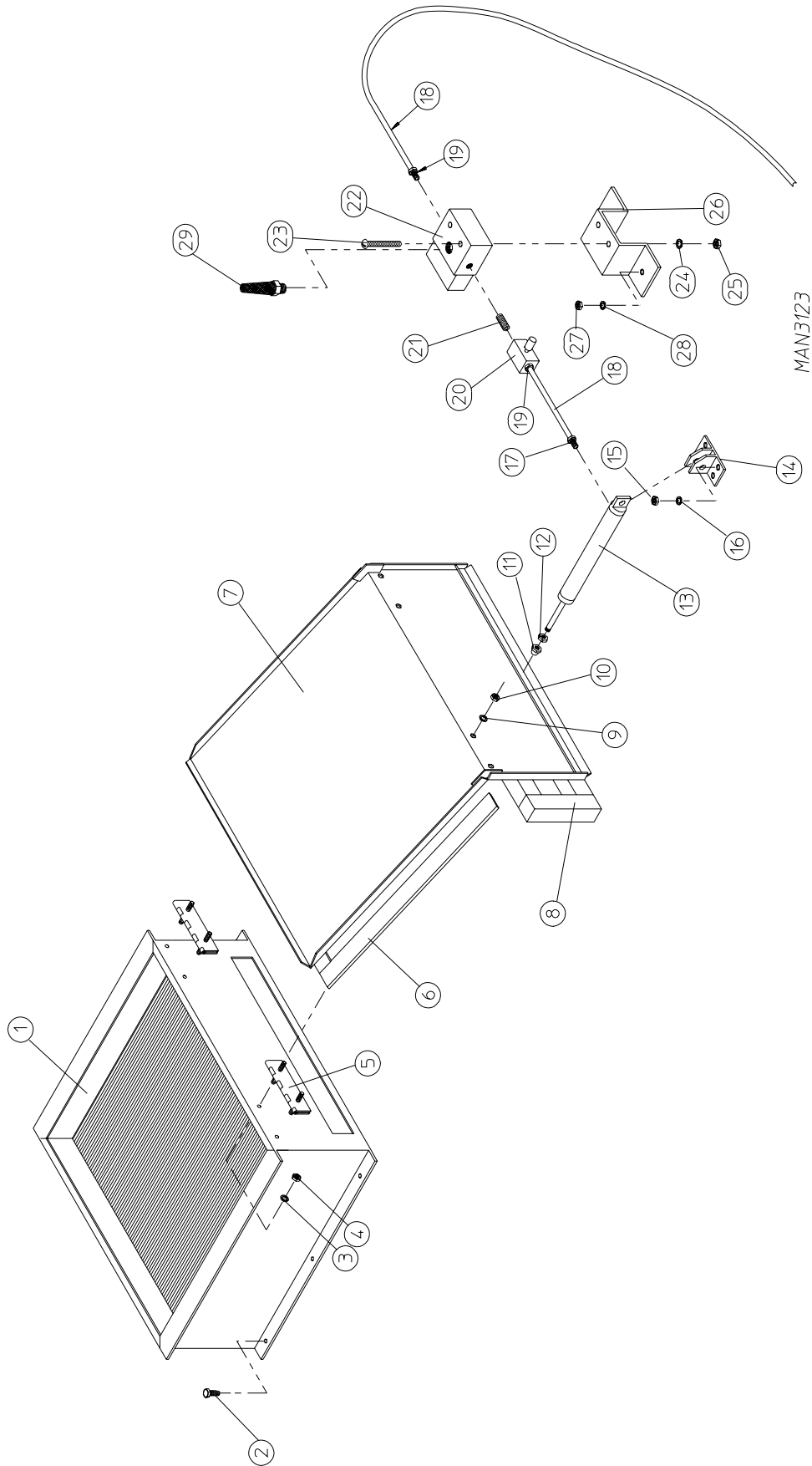

<u>Illus. No.</u>	<u>Part No.</u>	<u>Qty.</u>	<u>Description</u>
1	165020	1	Steam Coil Assembly
2	150523	6	1/4-20 x 3/4" Hex Head TEK Screw
3	153007	4	1/4" Lock Washer
4	152002	4	1/4-20 Hex Nut
5	820321	2	Steam Damper Hinge Assembly
6	115995	108	Steam Damper Gasket (sold by the inch)
7	880792	1	Steam Damper Assembly (includes illus. nos. 6 through 8)
8	102350	1	Steam Damper Foam
9	153007	4	1/4" Lock Washer
10	152002	4	1/4-20 Hex Nut
11	151008	1	5/8-18 Stainless Steel Acorn Nut
12	152030	1	5/8-18 Jam Nut
13	100525	1	2" Bore x 4" Stroke Piston
14	100526	1	Piston Pivot Bracket
15	152002	4	1/4-20 Hex Nut
16	153007	4	1/4" Lock Washer
17	105609	1	1/4" Poly x 1/4" M.P.T. Connector
18	143115	16	1/4" O.D. Tubing (sold by the foot)
19	100472	2	1/4" Poly x 1/8" M.P.T. Connector
20	100496	1	1/8" Needle Valve
21	143238	1	1/8" Brass Close Nipple
22	100498	1	3-Way Micro Valve
23	150002	2	#6-32 x 1" Phillips Round Head Machine Screw
24	153010	2	#6 Star Washer
25	152000	2	#6-32 Hex Nut
26	330987	1	Micro Valve Support
27	152002	2	1/4-20 Hex Nut
28	153007	2	1/4" Lock Washer
29	100520	1	1/8" N.P.T. Silencer (muffler)

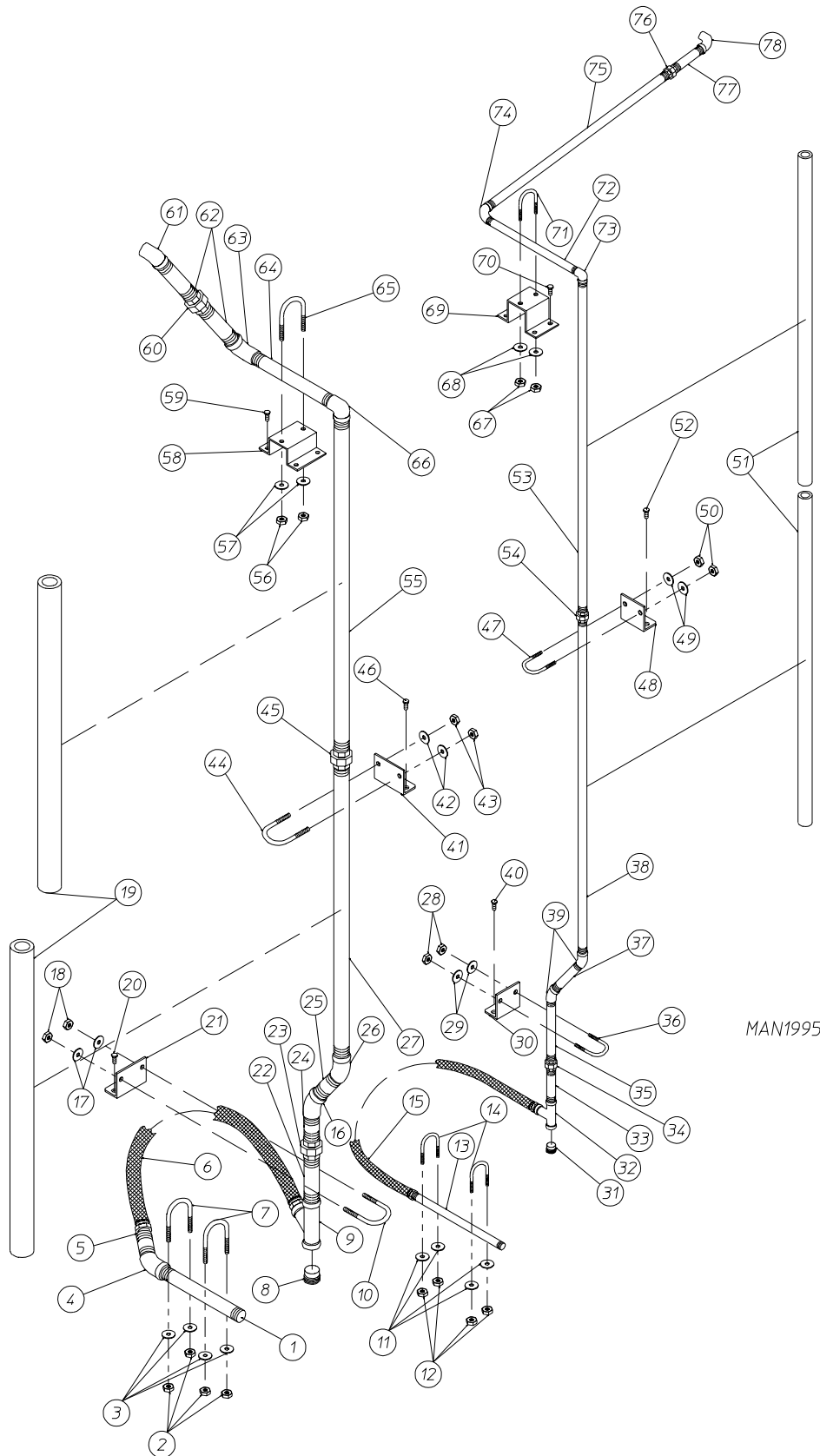

MAN1995

1-WAY TILT

<u>Illus. No.</u>	<u>Part No.</u>	<u>Qty.</u>	<u>Description</u>
1	142737	1	1-1/2" x 7-3/4" Nipple
2	152004	4	5/16-18 Hex Nut
3	153002	4	5/16" Lock Washer
4	142915	1	1-1/2" x 45° Elbow
5	142738	1	1-1/2" x 2" Nipple
6	143139	1	1-1/2" x 60" Flex Hose
7	154351	2	1-1/2" Pipe U-Bolt
8	142747	1	1/2" Pipe Plug
9	142743	1	1-1/2" x 1/2" x 1-1/2" Tee
10	154351	1	1-1/2" Pipe U-Bolt
11	153007	4	1/4" Lock Washer
12	152002	4	1/4-20 Hex Nut
13	142732	1	3/4" x 9-1/4" Nipple
14	154354	2	3/4" Pipe U-Bolt
15	143132	1	3/4" x 60" Flex Hose
16	142915	1	1-1/2" x 45° Elbow
17	153002	2	5/16" Lock Washer
18	152004	2	5/16-18 Hex Nut
19	142995	2	1-1/2" Pipe Insulation
20	150522	2	1/4-20 x 1/2" Hex Head TEK Screw
21	332828	1	Steam Inlet Pipe Bracket
22	142843	1	1-1/2" x 4" Nipple
23	142603	1	1-1/2" Union
24	142738	1	1-1/2" x 2" Nipple
25	142738	1	1-1/2" x 2" Nipple
26	142915	1	1-1/2" x 45° Elbow
27	142833	1	1-1/2" x 26" Nipple
28	152002	2	1/4-20 Hex Nut
29	153007	2	1/4" Lock Washer
30	332830	1	Condensate Pipe Bracket
31	142834	1	3/4" Pipe Plug
32	142909	1	3/4" Tee
33	142720	1	3/4" x 11" Nipple
34	142601	1	3/4" Union
35	142709	1	3/4" x 2" Nipple
36	154354	1	3/4" Pipe U-Bolt
37	142708	1	3/4" x 3" Nipple
38	142721	1	3/4" x 28" Nipple
39	142741	2	3/4" x 45° Elbow
40	150522	2	1/4-20 x 1/2" Hex Head TEK Screw
41	332828	1	Steam Inlet Pipe Bracket
42	153002	2	5/16" Lock Washer
43	152004	2	5/16-24 Hex Nut
44	154351	1	1-1/2" Pipe U-Bolt
45	142603	1	1-1/2" Union

continued on page 66

continued from page 65

<u>Illus. No.</u>	<u>Part No.</u>	<u>Qty.</u>	<u>Description</u>
46	150522	2	1/4-20 x 1/2" Hex Head TEK Screw
47	154354	1	3/4" Pipe U-Bolt
48	332830	1	Condensate Pipe Bracket
49	153007	2	1/4" Lock Washer
50	152002	2	1/4-20 Hex Nut
51	142994	2	3/4" Pipe Insulation
52	150522	2	1/4-20 x 1/2" Hex Head TEK Screw
53	142733	1	3/4" x 30" Nipple
54	142601	1	3/4" Union
55	142570	1	1-1/2" x 30" Nipple
56	152004	2	5/16-24 Hex Nut
57	153002	2	5/16" Lock Washer
58	332827	1	Top Steam Inlet Pipe Bracket
59	150522	4	1/4-20 x 1/2" Hex Head TEK Screw
60	142603	1	1-1/2" Union
61	142742	1	2" x 1-1/2" 90° Reducing Elbow
62	142843	2	1-1/2" x 4" Nipple
63	142512	1	1-1/2" x 90° Elbow
64	142737	1	1-1/2" x 7-3/4" Nipple
65	154351	1	1-1/2" Pipe U-Bolt
66	142512	1	1-1/2" x 90° Elbow
67	152002	2	1/4-20 Hex Nut
68	153007	2	1/4" Lock Washer
69	332829	1	Top Condensate Pipe Bracket
70	150522	4	1/4-20 x 1/2" Hex Head TEK Screw
71	154354	1	3/4" Pipe U-Bolt
72	142732	1	3/4" x 9-1/4" Nipple
74	142504	1	3/4" x 90° Elbow
75	142829	1	3/4" x 20" Nipple
76	142601	1	3/4" Union
77	142709	1	3/4" x 2" Nipple
78	142740	1	2" x 3/4" 90° Reducing Elbow

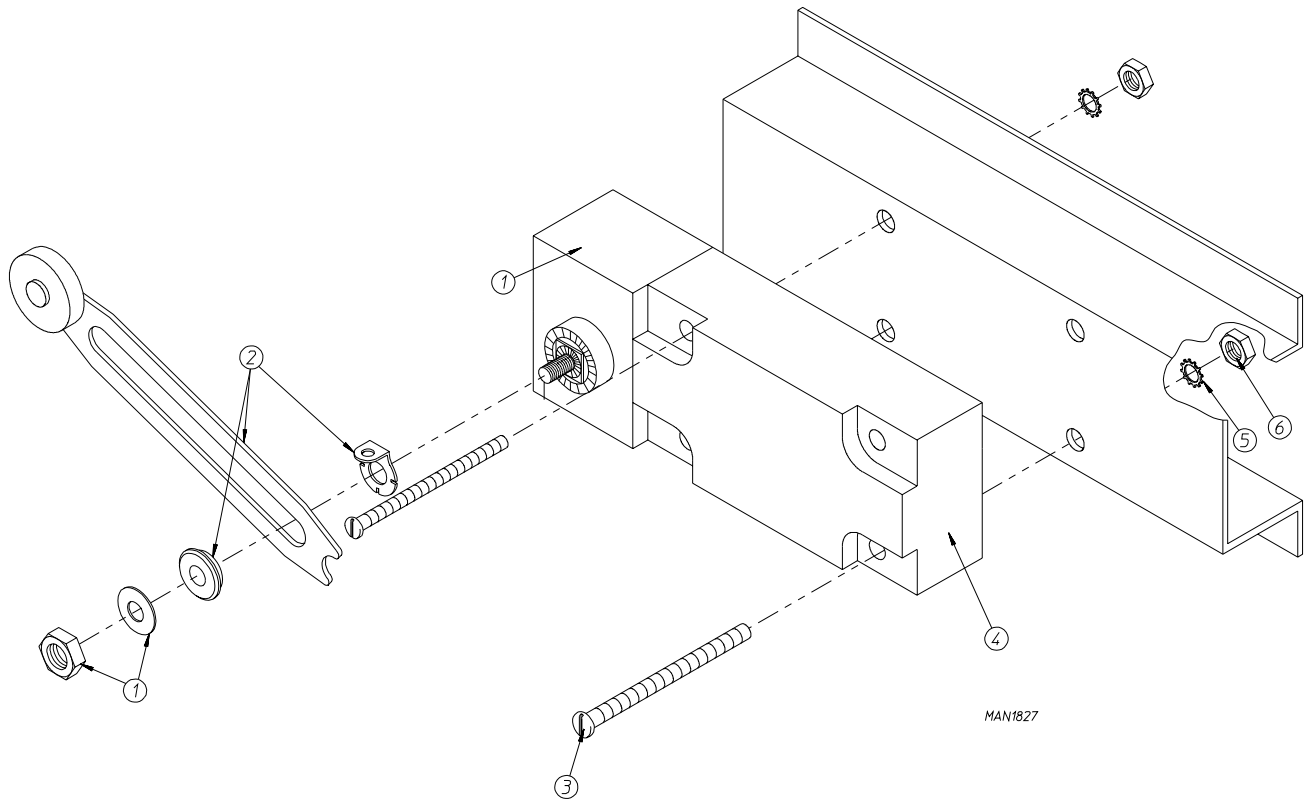

NOTE: One (1) Assembly Required for 1-Way Tilt Models
 Two (2) Assemblies Required for 2-Way Tilt Models

<u>Illus. No.</u>	<u>Part No.</u>	<u>Qty.</u>	<u>Description</u>
1	881252	1	Tilt Switch Assembly Complete (includes illus. nos. 1, 2, and 4)
	122365	1	Limit Switch Rotary Head
2	122369	1	Tilt Switch Arm
3	150211	4	#10-32 x 2" Round Head Machine Screw
4	122367	1	Tilt Switch Body
5	153009	4	#10 Star Washer
6	152008	4	#10-32 Hex Nut

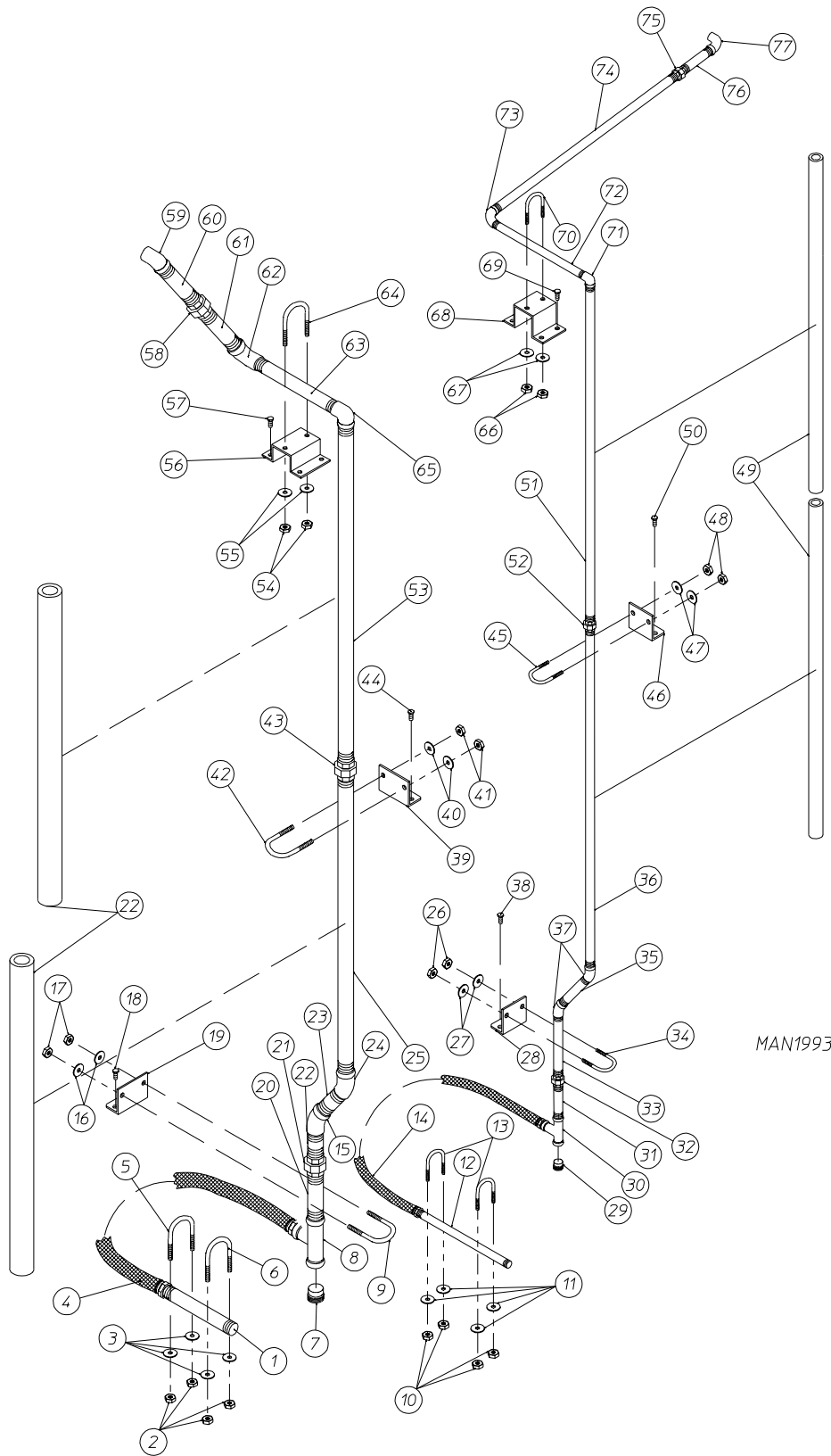

2-WAY TILT

<u>Illus. No.</u>	<u>Part No.</u>	<u>Qty.</u>	<u>Description</u>
1	142843	1	1-1/2" x 4" Nipple
2	152004	4	5/16-18 Hex Nut
3	153002	4	5/16" Lock Washer
4	143139	1	1-1/2" x 60" Flex Hose
5	154352	1	2" Pipe U-Bolt
6	154351	1	1-1/2" Pipe U-Bolt
7	142747	1	1/2" Pipe Plug
8	142743	1	1-1/2" x 1/2" x 1-1/2" Tee
9	154351	1	1-1/2" Pipe U-Bolt
10	152002	4	1/4-20 Hex Nut
11	153007	4	1/4" Lock Washer
12	142732	1	3/4" x 9-1/4" Nipple
13	154354	2	3/4" Pipe U-Bolt
14	143132	1	3/4" x 60" Flex Hose
15	142915	1	1-1/2" x 45° Elbow
16	153002	2	5/16" Lock Washer
17	152004	2	5/16-18 Hex Nut
18	150522	2	1/4-20 x 1/2" Hex Head TEK Screw
19	332828	1	Steam Inlet Pipe Bracket
20	142843	1	1-1/2" x 4" Nipple
21	142603	1	1-1/2" Union
22	142738	1	1-1/2" x 2" Nipple
23	142738	1	1-1/2" x 2" Nipple
24	142915	1	1-1/2" x 45° Elbow
25	142833	1	1-1/2" x 26" Nipple
26	152002	2	1/4-20 Hex Nut
27	153007	2	1/4" Lock Washer
28	332830	1	Condensate Pipe Bracket
29	142834	1	3/4" Pipe Plug
30	142909	1	3/4" Tee
31	142720	1	3/4" x 11" Nipple
32	142601	1	3/4" Union
33	142709	1	3/4" x 2" Nipple
34	154354	1	3/4" Pipe U-Bolt
35	142708	1	3/4" x 3" Nipple
36	142721	1	3/4" x 28" Nipple
37	142741	2	3/4" x 45° Elbow
38	150522	2	1/4-20 x 1/2" Hex Head TEK Screw
39	332828	1	Steam Inlet Pipe Bracket
40	153002	2	5/16" Lock Washer
41	152004	2	5/16-18 Hex Nut
42	154351	1	1-1/2" Diameter Pipe U-Bolt
43	142603	1	1-1/2" Union
44	150522	2	1/4-20 x 1/2" Hex Head TEK Screw
45	154354	1	3/4" Pipe U-Bolt

continued on page 70

continued from page 69

<u>Illus. No.</u>	<u>Part No.</u>	<u>Qty.</u>	<u>Description</u>
46	332830	1	Condensate Pipe Bracket
47	153007	2	1/4" Lock Washer
48	152002	2	1/4-20 Hex Nut
49	142994	2	3/4" Pipe Insulation
50	150522	2	1/4-20 x 1/2" Hex Head TEK Screw
51	142733	1	3/4" x 30" Nipple
52	142601	1	3/4" Union
53	142570	1	1-1/2" x 30" Nipple
54	152004	2	5/16-18 Hex Nut
55	153002	2	5/16" Lock Washer
56	332827	1	Top Steam Inlet Pipe Bracket
57	150522	4	1/4-20 x 1/2" Hex Head TEK Screw
58	142603	1	1-1/2" Union
59	142742	1	2" x 1-1/2" 90° Reducing Elbow
60	142905	1	1-1/2" x 3" Nipple
61	142572	1	1-1/2" x 12" Nipple
62	142512	1	1-1/2" x 90° Elbow
63	142737	1	1-1/2" x 7-3/4" Nipple
64	154351	1	1-1/2" Pipe U-Bolt
65	142512	1	1-1/2" x 90° Elbow
66	152002	2	1/4-20 Hex Nut
67	153007	2	1/4" Lock Washer
68	332829	1	Top Condensate Pipe Bracket
69	150522	4	1/4-20 x 1/2" Hex Head TEK Screw
70	154354	1	3/4" Pipe U-Bolt
71	142504	1	3/4" x 90° Elbow
72	142732	1	3/4" x 9-1/4" Nipple
73	142504	1	3/4" x 90° Elbow
74	142720	1	3/4" x 11" Nipple
75	142601	1	3/4" Union
76	142708	1	3/4" x 3" Nipple
77	142740	1	2" x 3/4" 90° Reducing Elbow

1-WAY TILT

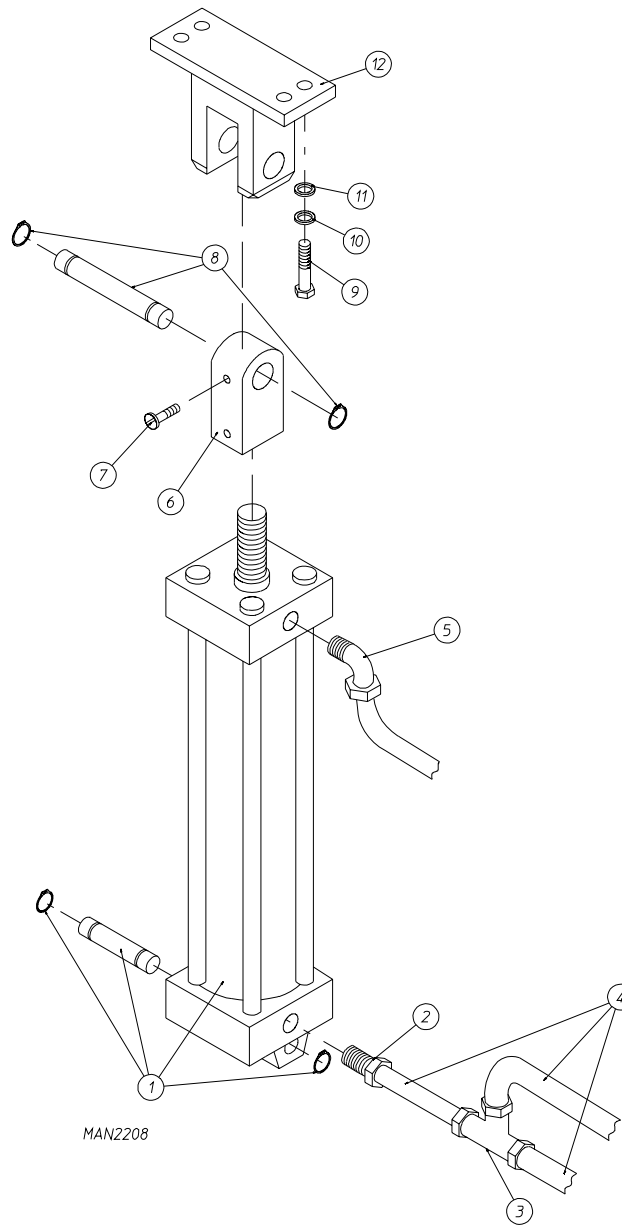

<u>Illus. No.</u>	<u>Part No.</u>	<u>Qty.</u>	<u>Description</u>
1	100450	1	5" Bore x 11" Stroke Piston
2	143283	1	3/8" Poly x 3/8" M.P.T. Connector
3	143221	1	3/8" Poly Brass Tee
4	143120	20	3/8" Poly Tubing (sold by the foot)
5	143213	1	3/8" Poly x 3/8" M.P.T. Brass Elbow
6	100553	1	Rod Eye
7	154315	2	1/4-20 x 1" Socket Head Set Screw
8	100488	1	1" Pin with Rings
9	150605	4	1/2-13 x 1-1/2" Hex Head Machine Bolt
10	153026	4	1/2" Lock Washer
11	153011	4	9/16" Flat Washer
12	881171	1	Clevis Assembly

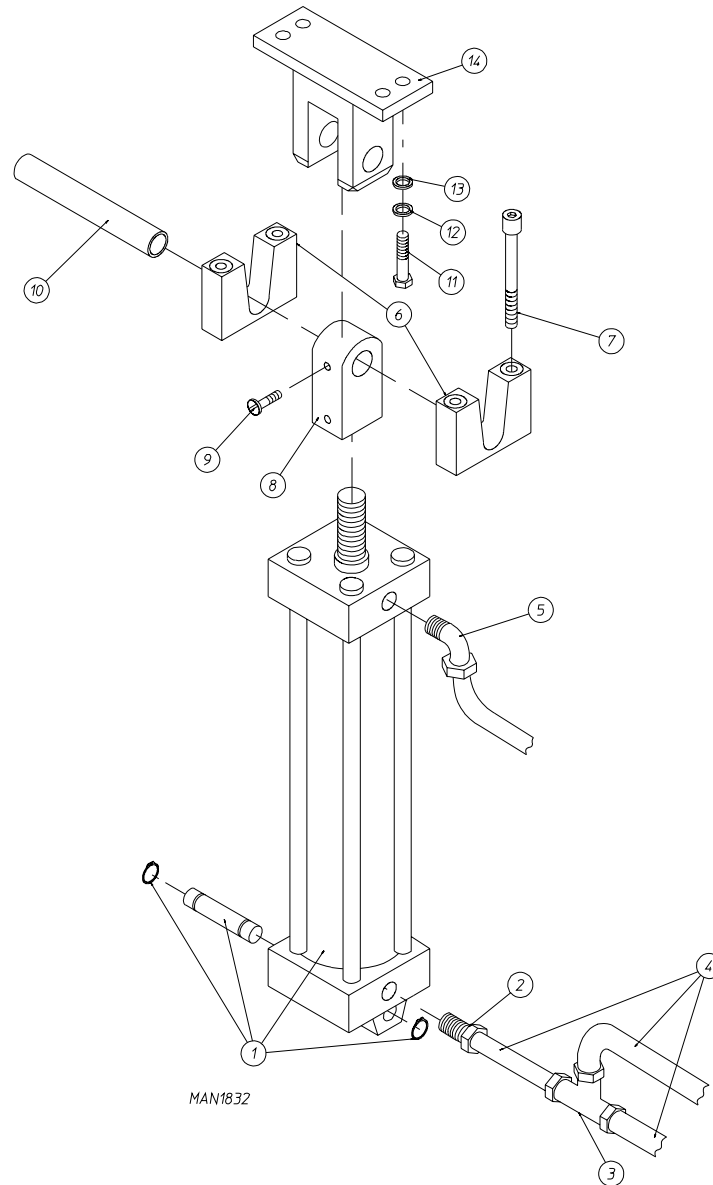

<u>Illus. No.</u>	<u>Part No.</u>	<u>Qty.</u>	<u>Description</u>
1	100450	1	5" Bore x 11" Stroke Piston
2	143283	1	3/8" Poly x 3/8" M.P.T. Connector
3	143221	1	3/8" Brass Poly Tee
4	143120	20	3/8" Poly Tubing (sold by the foot)
5	143213	1	3/8" Poly x 3/8" M.P.T. Brass Elbow
6	102381	2	Cylinder Pin Nylon Bumper
7	150435	4	3/8-16 x 3" Socket Head Cap Screw
8	100553	1	Rod Eye
9	154315	2	1/4-20 x 1" Socket Head Set Screw
10	331543	1	1" Pin
11	150599	4	1/2-20 x 1-1/4" Hex Head Machine Bolt
12	153026	4	1/2" Lock Washer
13	153011	4	9/16" Flat Washer
14	881170	1	Clevis Assembly

For 1 AUTOMATIC DOOR

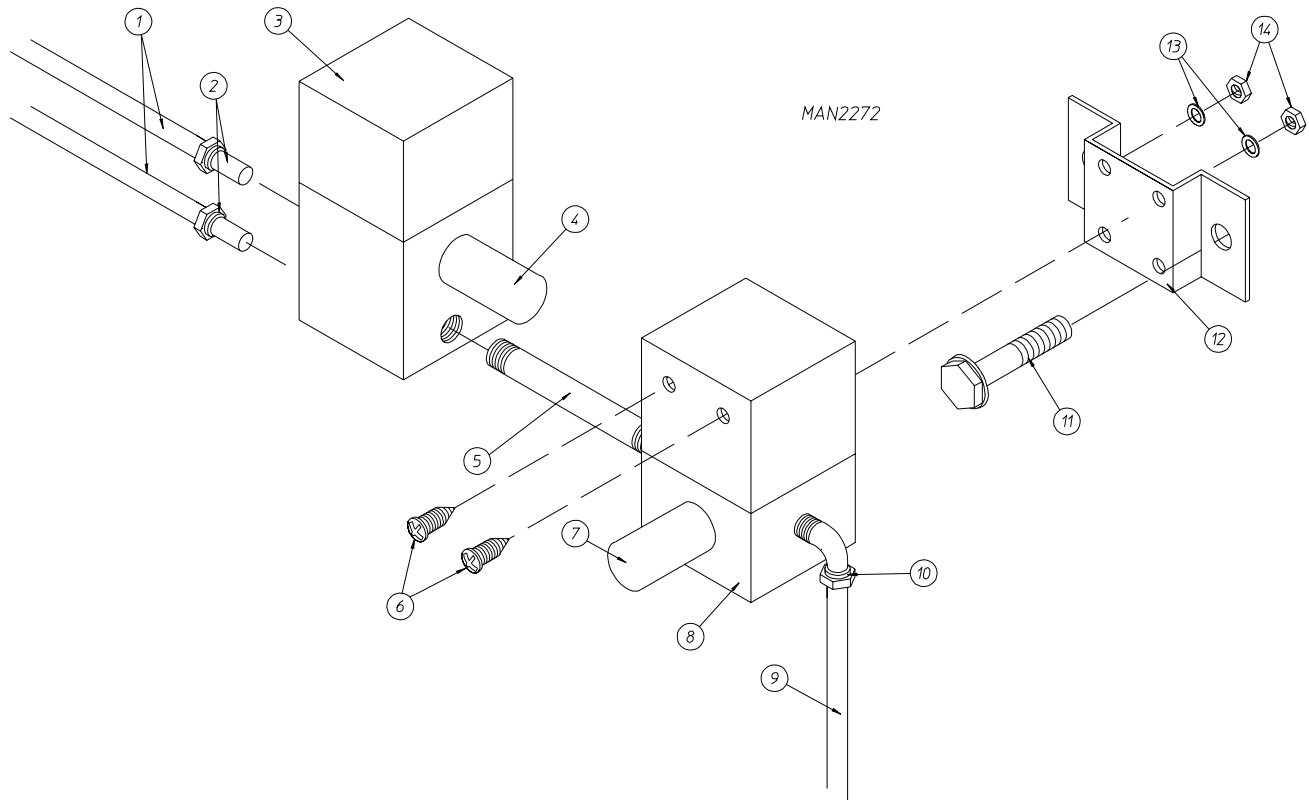

<u>Illus. No.</u>	<u>Part No.</u>	<u>Qty.</u>	<u>Description</u>
1	143115	-	1/4" Poly-Flo Tubing (sold by the foot)
2	100472	2	1/4" Poly x 1/8" M.P.T. Connector
3	100468	1	4-Way Valve - 24 VAC
4	100520	1	1/8" Muffler
5	143239	1	1/8" x 2-1/2" Brass Nipple
6	150002	2	#6-32 x 1" Phillips Round Head Machine Screw
7	100520	1	1/8" Muffler
8	100498	1	3-Way Valve - 24 VAC
9	143115	-	1/4" Poly-Flo Tubing (sold by the foot)
10	143149	1	1/4" Poly x 1/8" M.P.T. Connector Elbow
11	150522	2	1/4-20 x 1/2" Hex Head TEK Screw
12	330987	1	Valve Mounting Bracket
13	153010	2	#6 Star Washer
14	152000	2	#6-32 Hex Nut

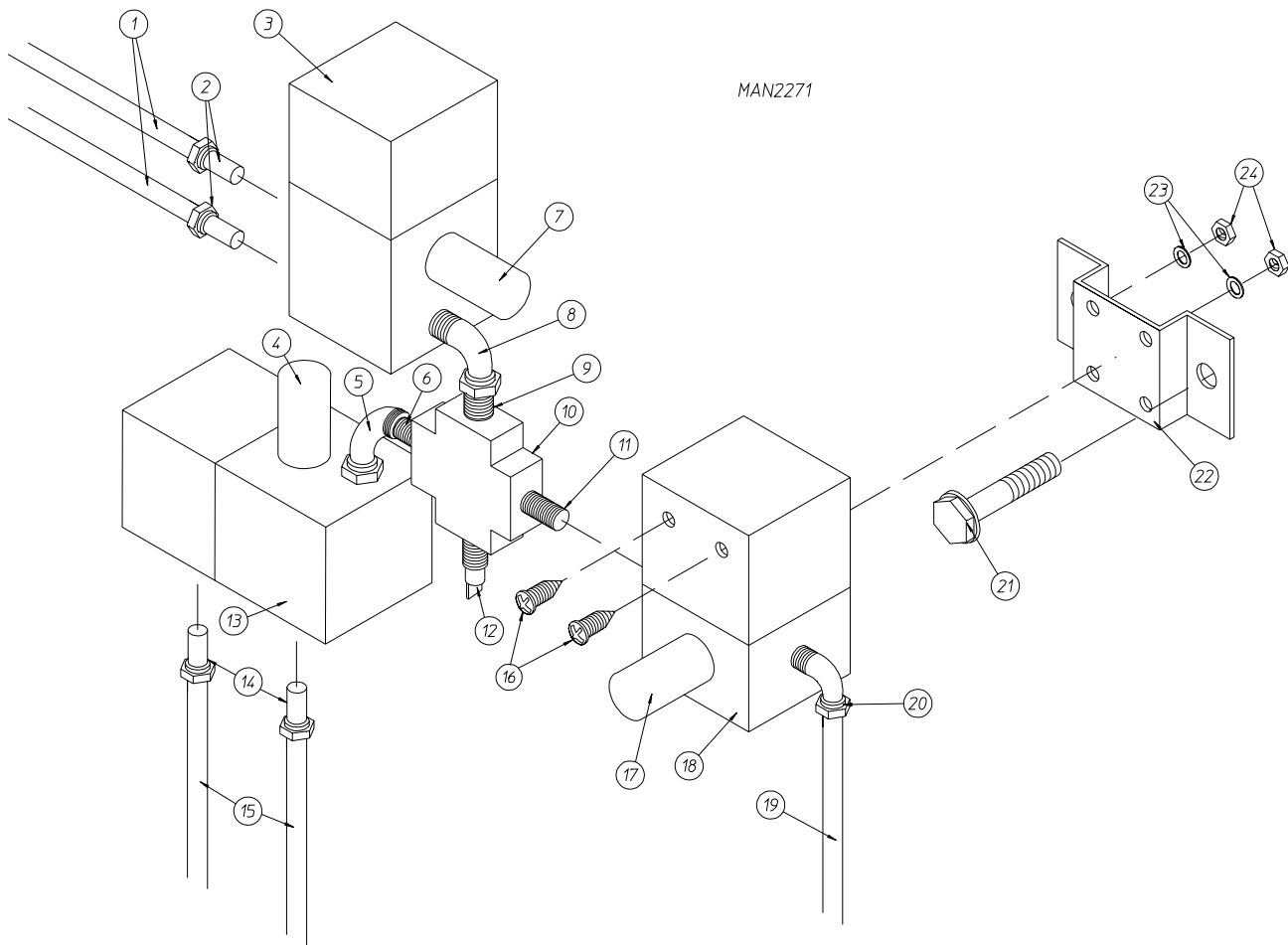

For 2 AUTOMATIC DOORS

<u>Illus. No.</u>	<u>Part No.</u>	<u>Qty.</u>	<u>Description</u>
1	143115	-	1/4" Poly-Flo Tubing (sold by the foot)
2	100472	2	1/4" Poly x 1/8" M.P.T. Connector
3	100468	1	4-Way Valve - 24 VAC
4	100520	1	1/8" Muffler
5	143268	1	1/8" Brass Street Elbow
6	143238	1	1/8" Close Nipple
7	100520	1	1/8" Muffler
8	143268	1	1/8" Brass Street Elbow
9	143238	1	1/8" Close Nipple
10	143237	1	1/8" Brass Cross
11	143238	1	1/8" Close Nipple
12	143250	1	1/8" Brass Plug
13	100468	1	4-Way Valve - 24 VAC
14	100472	2	1/4" Poly x 1/8" M.P.T. Connector
15	143115	-	1/4" Poly-Flo Tubing (sold by the foot)
16	150002	2	#6-32 x 1" Phillips Round Head Machine Screw
17	100520	1	1/8" Muffler
18	100498	1	3-Way Valve - 24 VAC
19	143115	-	1/4" Poly-Flo Tubing
20	143149	1	1/4" Poly x 1/8" M.P.T. Connector Elbow
21	150522	2	1/4-20 x 1/2" Hex Head TEK Screw
22	330987	1	Valve Mounting Bracket
23	153010	2	#6 Star Washer
24	152000	2	#6-32 Hex Nut

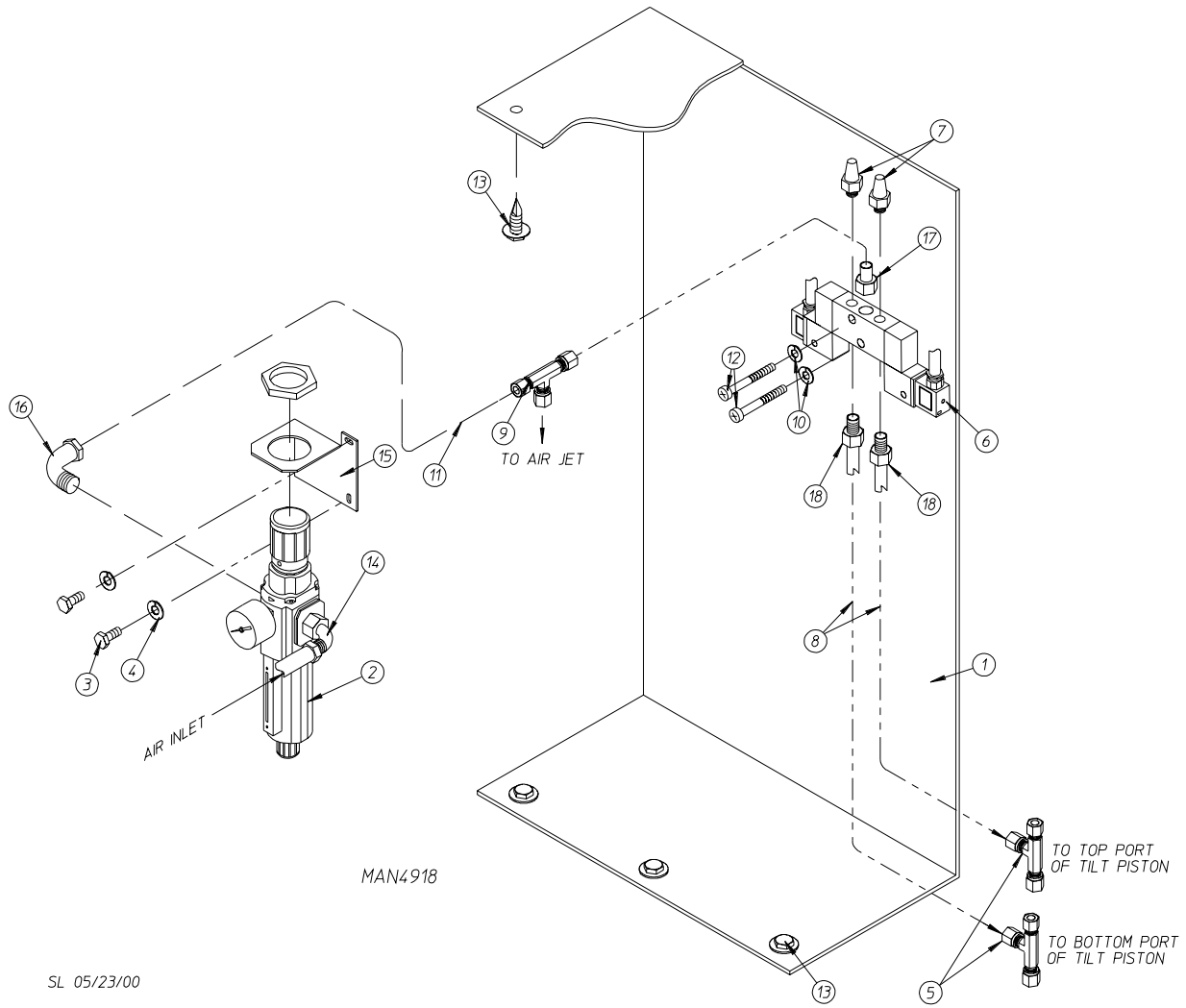

1-WAY TILT

<u>Illus. No.</u>	<u>Part No.</u>	<u>Qty.</u>	<u>Description</u>
1	821369	1	Pneumatic Plate Assembly Complete (includes illus. nos. 2 through 18)
	826810	1	Pneumatic Plate ONLY
2	100479	1	Filter Regulator Gauge
3	151001	2	#8-32 Hex Nut
4	153007	2	1/4" Lock Washer
5	143221	2	3/8" Brass Union Tee
6	100528	1	Tilting Solenoid 24 VAC, 5-Port, 3-Position
7	100520	2	1/8" Mufflers
8	143120	5'	3/8" Poly-Flo Tubing
9	143156	1	1/4" Union Tee
10	153007	2	1/4" Lock Washer
11	143110	8'	1/4" O.D. Poly-Flo Tubing
12	150101	2	8-32 x 1-1/4" Phillips Pan Head Machine Screw
13	150522	6	1/4-20 x 1/2" Hex Washer
14	143213	1	3/8" Poly x 3/8" Elbow Brass
15	332624	1	3/8" Norgren Filter/Regulator Adapter Bracket
16	143290	1	Brass Fitting
17	143165	1	1/4" M.P.T. x 1/4" Tube Connector
18	143166	2	1/4" M.P.T. x 1/4" Tube Connector

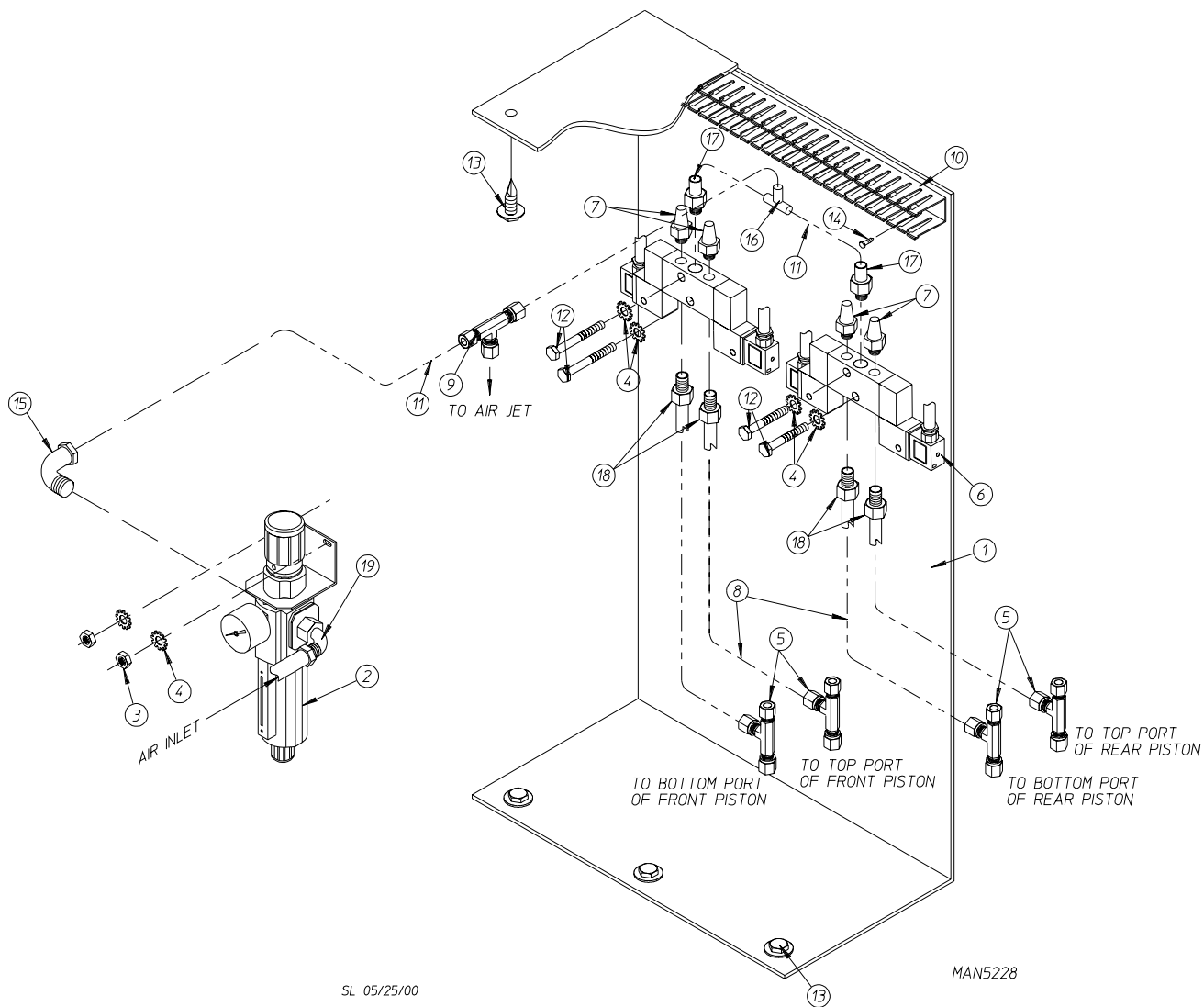

2-WAY TILT

<u>Illus. No.</u>	<u>Part No.</u>	<u>Qty.</u>	<u>Description</u>
1	826809	1	Pneumatic Plate
2	100479	1	Filter/Regulator Gauge
3	151001	2	8-32 Hex Nut
4	153012	6	#8 Star Washer
5	143221	4	3/8" Brass Union Tee
6	100528	2	Tilting Solenoid 24 VAC, 5-Port, 3-Position
7	100520	4	1/8" Muffler
8	143120	8'	3/8 Poly-Flo Tubing
9	143156	1	1/4" Union Tee
10	121429	14"	1" x 2" Wiring Duct
11	143115	14'	1/4" Poly-Flo Tubing (sold by the foot)
12	150109	4	#8-32 x 2" Screw
13	150522	6	1/4-20 x 1/2" Hex Washer TEK
14	150309	5	10-16 x 1/2" Hex Head TEK Screw
15	143153	1	1/4" Poly x 1/4" Male N.P.T. 90° Elbow
16	143156	1	1/4 Poly-Flo Tee
17	143165	2	1/4 M.P.T. x 1/4 Tube Connector
18	143166	4	1/4 M.P.T. x 3/8 Poly Connector
19	143168	1	3/8" Poly x 1/4" Male N.P.T. 90° Elbow
20	121493	6	1/4" Nylon Push In Mount (not shown)
21	121499	6	5-1/2" Wire Tie (not shown)

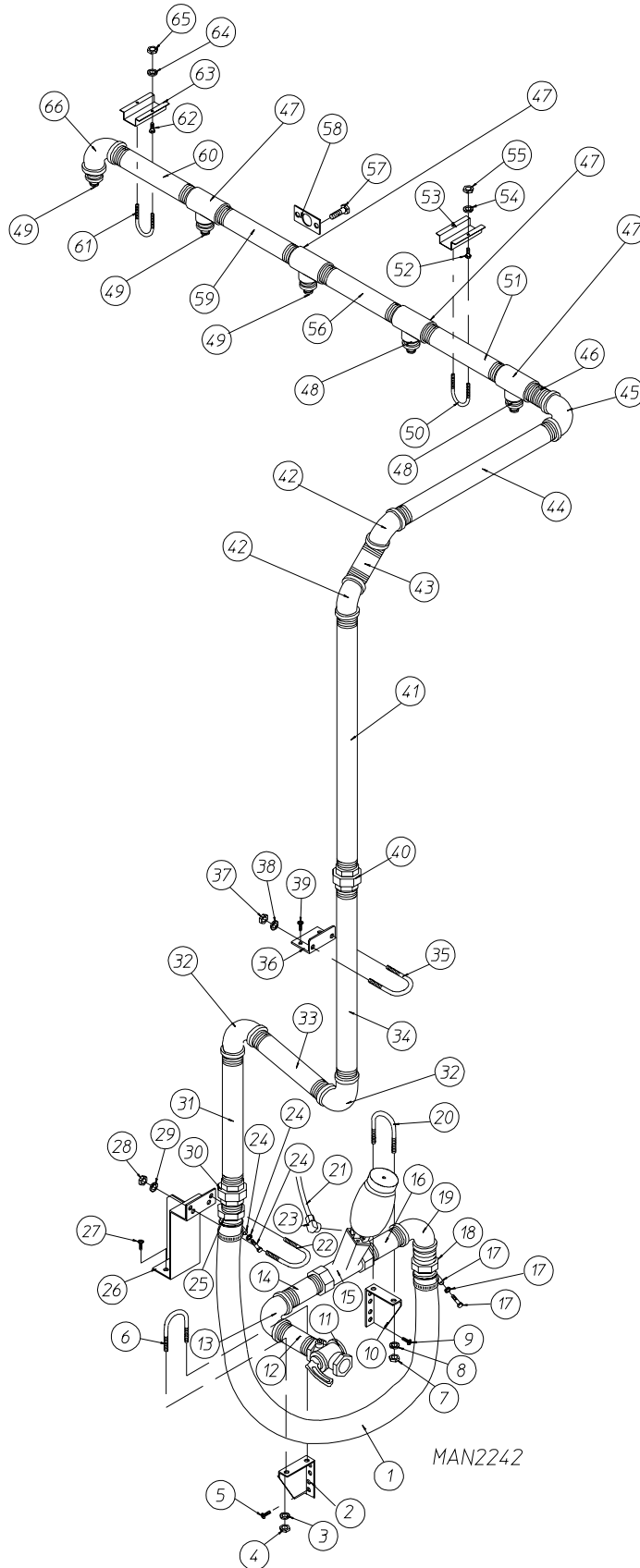

<u>Illus. No.</u>	<u>Part No.</u>	<u>Qty.</u>	<u>Description</u>
1	143135	1	48" Flex Hose
2	331794	1	Inlet Pipe Bracket
3	153007	2	1/4" Lock Washer
4	152002	2	1/4-20 Hex Nut
5	150522	2	1/4-20 x 1/2" Hex Head TEK Screw
6	154350	1	1" Pipe U-Bolt
7	152002	2	1/4-20 Hex Nut
8	153007	2	1/4" Lock Washer
9	150522	2	1/4-20 x 1/2" Hex Head TEK Screw
10	331794	1	Inlet Pipe Bracket
11	143556	1	1" Ball Valve
12	142808	1	1" x 3" Nipple
13	142548	1	1" x 90° Elbow
14	142808	1	1" x 3" Nipple
15	100557	1	1" Air Operated Water Valve
16	142808	1	1" x 3" Nipple
17	143137	1	Hose Clamp
18	143136	1	1" Hose Nipple
19	142548	1	1" x 90° Elbow
20	154350	1	1" Pipe U-Bolt
21	143100	12	1/4" Aluminum Tubing (sold by the foot)
22	154350	1	1" Pipe U-Bolt
23	143210	1	1/4" Compression x 1/4" M.P.T. Elbow
24	143137	1	Hose Clamp
25	143136	1	1" Hose Nipple
26	881232	1	Lower Sprinkler Bracket
27	150522	2	1/4-20 x 1/2" Hex Head TEK Screw
28	152002	2	1/4-20 Hex Nut
29	153007	2	1/4" Lock Washer
30	142602	1	1" Union
31	142585	1	1" x 18" Nipple
32	142548	2	1" x 90° Elbow
33	142579	1	1" x 6" Nipple
34	142744	1	1" x 12" Nipple
35	154350	1	1" Pipe U-Bolt
36	334255	1	Pipe Bracket
37	152002	2	1/4-20 Hex Nut
38	153007	2	1/4" Lock Washer
39	150522	2	1/4-20 x 1/2" Hex Head TEK Screw
40	142602	1	1" Union

continued on page 82

continued from page 81

<u>Illus. No.</u>	<u>Part No.</u>	<u>Qty.</u>	<u>Description</u>
41	142746	1	1" x 24" Nipple
42	142590	2	1" x 45° Elbow
43	142808	1	1" x 3" Nipple
44	142598	1	1" x 17" Nipple
45	142548	1	1" x 90° Elbow
46	142724	1	1" x 2" Nipple
47	142508	4	1" Tee
48	142926	5	1" x 1/4" Reducing Bushing
49	140927	5	1/4" Sprinkler Nozzle
50	154350	1	1" Pipe U-Bolt
51	142579	1	1" x 6" Nipple
52	150522	4	1/4-20 x 1/2" Hex Head TEK Screw
53	332941	1	Sprinkler Pipe Bracket
54	153007	2	1/4" Lock Washer
55	152002	2	1/4-20 Hex Nut
56	142579	1	1" x 6" Nipple
57	150523	2	1/4-20 x 3/4" Hex Head TEK Screw
58	331877	1	Temperature Probe Mounting Plate
59	142579	1	1" x 6" Nipple
60	142579	1	1" x 6" Nipple
61	154350	1	1" Pipe U-Bolt
62	150522	4	1/4-20 x 1/2" Hex Head TEK Screw
63	332941	1	Sprinkler Pipe Bracket
64	153007	2	1/4" Lock Washer
65	152002	2	1/4-20 Hex Nut
66	142548	1	1" x 90° Elbow

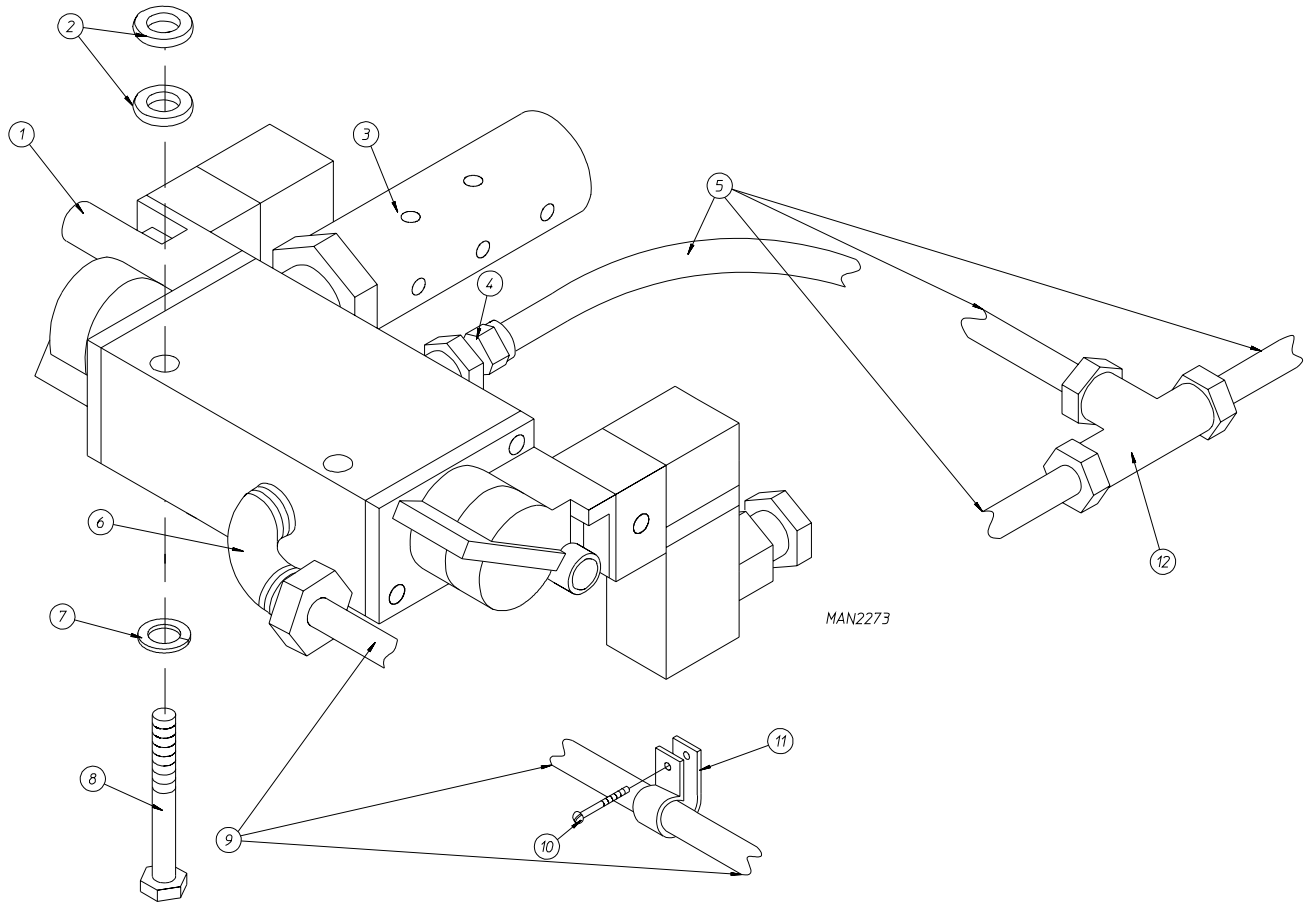

<u>Illus. No.</u>	<u>Part No.</u>	<u>Qty.</u>	<u>Description</u>
1	100556	1	120 VAC Sprinkler Solenoid
2	153018	4	1/4" Flat Washer
3	100462	1	3/8" Valve Muffler
4	143283	1	3/8" Poly x 3/8" M.P.T. Brass Connector
5	143120	6	3/8" Poly-Flo Tubing (sold by the foot)
6	143151	1	1/4" Compression x 3/8" M.P.T. Brass Elbow
7	153007	2	1/4" Lock Washer
8	150524	2	1/4-20 x 2" Hex Head Machine Bolt
9	143100	12	1/4" Aluminum Tubing (sold by the foot)
10	150415	2	#10-16 x 1/2" Phillips Round Head Crimptite Screw
11	154005	2	1/4" Tube Clip
12	143221	1	3/8" Poly Tee

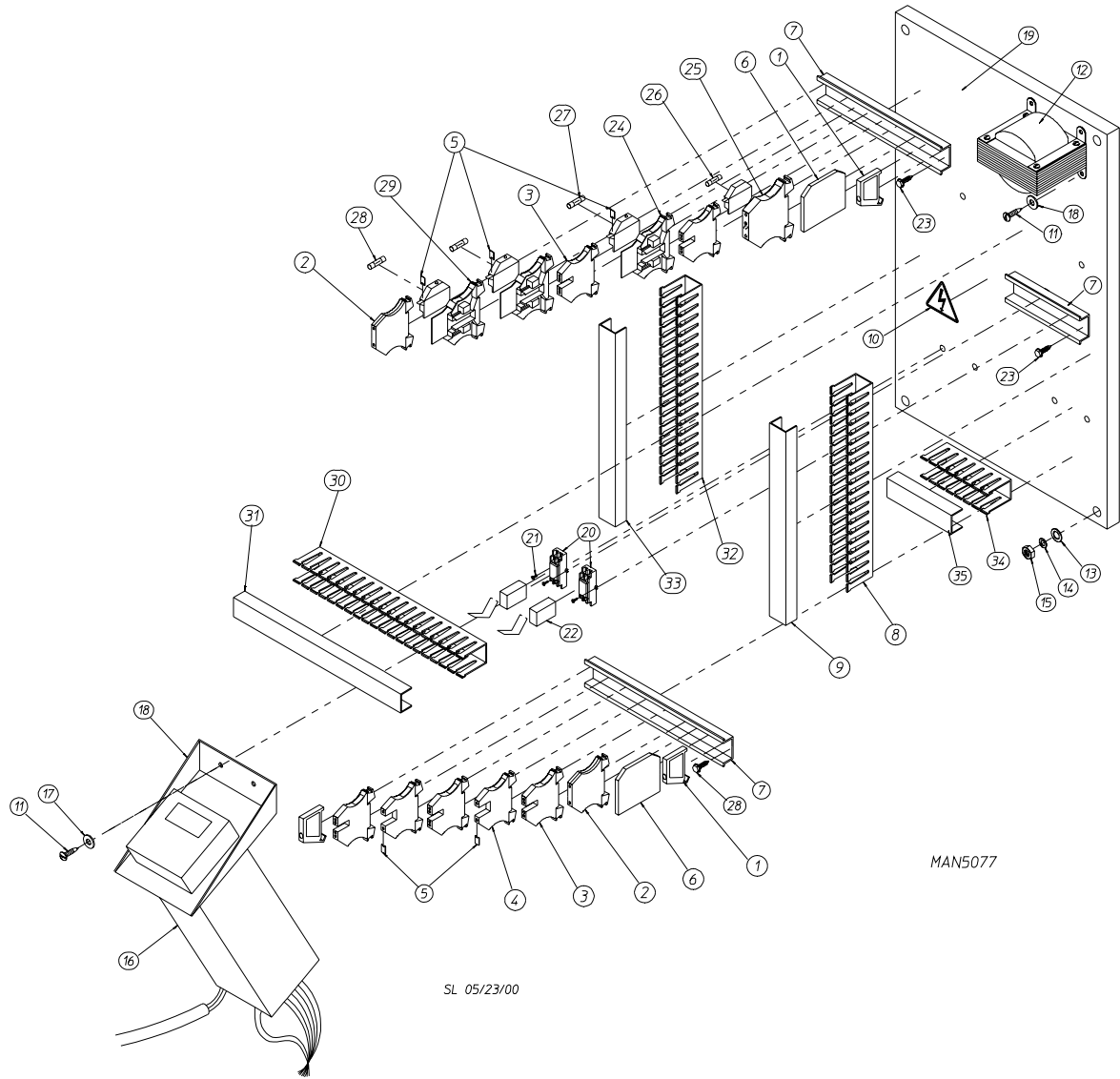

<u>Illus. No.</u>	<u>Part No.</u>	<u>Qty.</u>	<u>Description</u>
1	120765	2	Standard End Stop
2	120750	2	Ground Terminal Block
3	120761	8	4-Position Feed Thru Terminal Block
4	120758	7	Feed Thru Terminal Block
5	120999	5	Blank Marking Tags
6	120766	2	End Section
7	120768	16	35 x 15mm Din Mounting Rail
8	121429	12	Slotted Wall Wire Duct
9	121422	12	1" Wireway Cover
10	122424	1	Power Warning Label
11	150108	6	8-32 x 1/2" Phillips Pan Head Machine Screw
12	132091	1	208/240v to 120v Transformer
	132092	1	380/400v to 120v Transformer
	132006	1	416v to 120v Transformer
	132078	1	480v to 120v Transformer
13	153004	4	3/8" Flat Washer
14	153005	4	3/8" Lock Washer
15	152005	4	3/8-16 Hex Nut
16	881249	1	°C/°F Digital Temperature Controller Assembly
17	153000	6	#8 Flat Washers
18	333002	1	Sprinkler Mounting Bracket
19	334269	1	Sprinkler Panel ONLY
	814332	1	Sprinkler Panel Assembly Complete (includes illus. nos. 1 through 35)
20	131410	2	Double-Pole-Double-Throw (DPDT) Relay Socket
21	131411	4	Hold Down for Double-Pole-Double-Throw (DPDT) Relay
22	131405	2	Double-Pole-Double-Throw (DPDT) Relay with Smoked Case
23	150300	10	#10 x 3/8" Self Drilling Screw
24	120756	1	1/4" Fuse Terminal Block with Light Emmitting Diode (L.E.D.)
25	120754	1	5 x 20mm Fuse Terminal Block with Light Emmitting Diode (L.E.D.)
26	136039	1	1/4-Amp 5 x 20mm Fuse
27	136033	1	3-Amp Fuse
28	136050	1	1-Amp (slo blo) Fuse 208/240v ONLY
	136057	1	5-Amp (slo blo) Fuse 380-460v ONLY
29	120721	2	Fused Disconnect Terminal Block
30	121422	8	1" Wireway Cover
31	121429	8	Slotted Wall Wire Duct
32	121429	14	Slotted Wall Wire Duct
33	121422	14	1" Wireway Cover
34	121429	4	Slotted Wall Wire Duct
35	121422	4	1" Wireway Cover

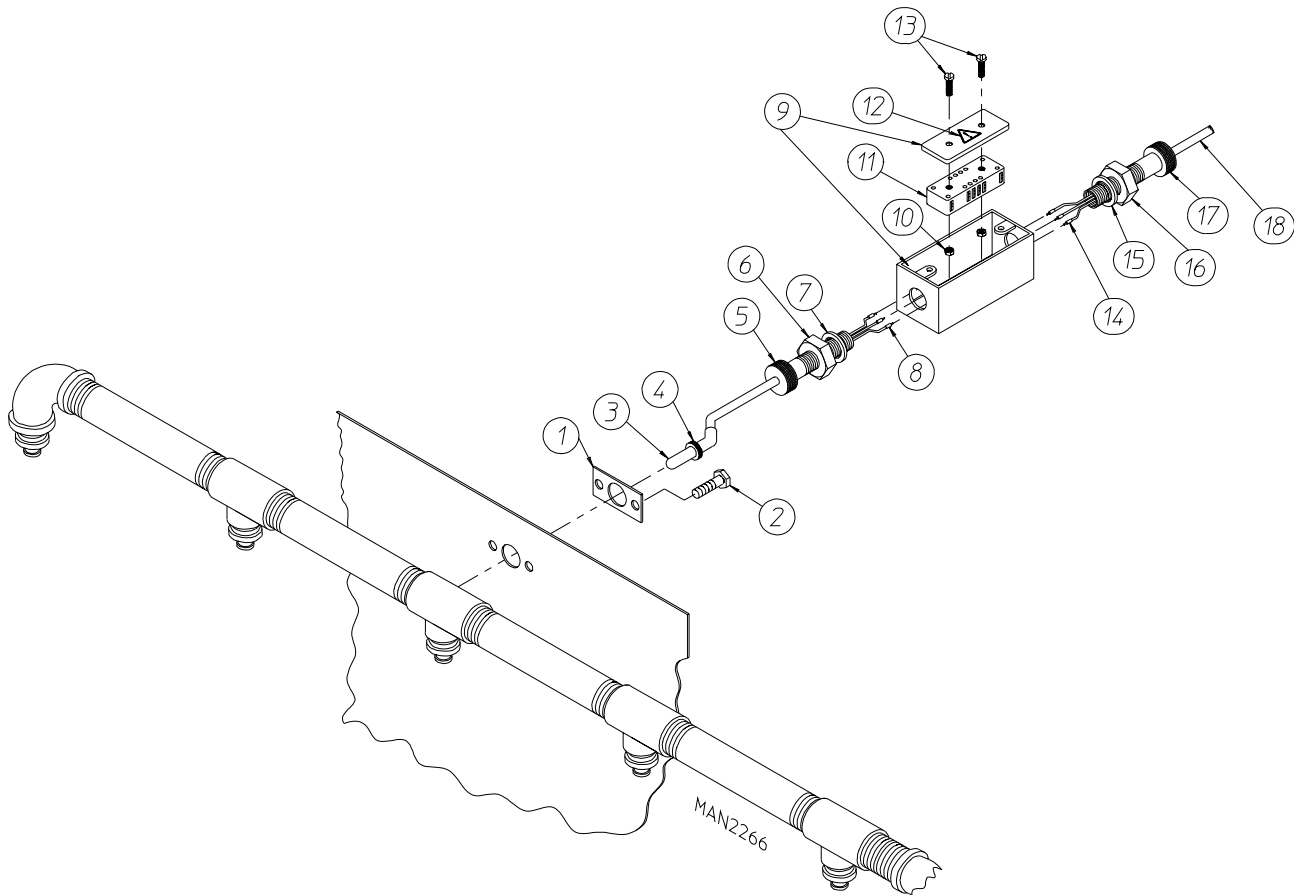

Illus. No.	Part No.	Qty.	Description
1	331877	1	Temperature Sensor Mounting Plate
2	150523	2	1/4-20 x 3/4" Hex Head TEK Screw
3	881227	1	Resistive Temperature Device (RTD) Sprinkler Temperature Probe Assembly (includes illus. nos. 3, 4, and 8)
4	143296	1	1/4" Compression Fitting
5	120652	1	1/2" N.P.T. Cord Grip (Red)
6	120915	1	1/2" N.P.T. Locknut
7	120914	1	1/2" Metal "O" Ring
8	122736	3	Yellow Ferrule
9	881228	1	Sprinkler Temperature Probe Box Assembly (includes illus. nos. 9 and 12)
10	152000	2	6-32 Hex Nut
11	120703	1	6-Position Terminal Block
12	122427	1	"!" Caution Label
13	150008	2	6-32 x 1-1/4" Phillips Round Head Machine Screw
14	122736	3	Yellow Ferrule
15	120914	1	1/2" Metal "O" Ring
16	120915	1	1/2" N.P.T. Locknut
17	120650	1	1/2" N.P.T. Cord Grip (white)
18	881229	1	Sprinkler Temperature Probe Harness

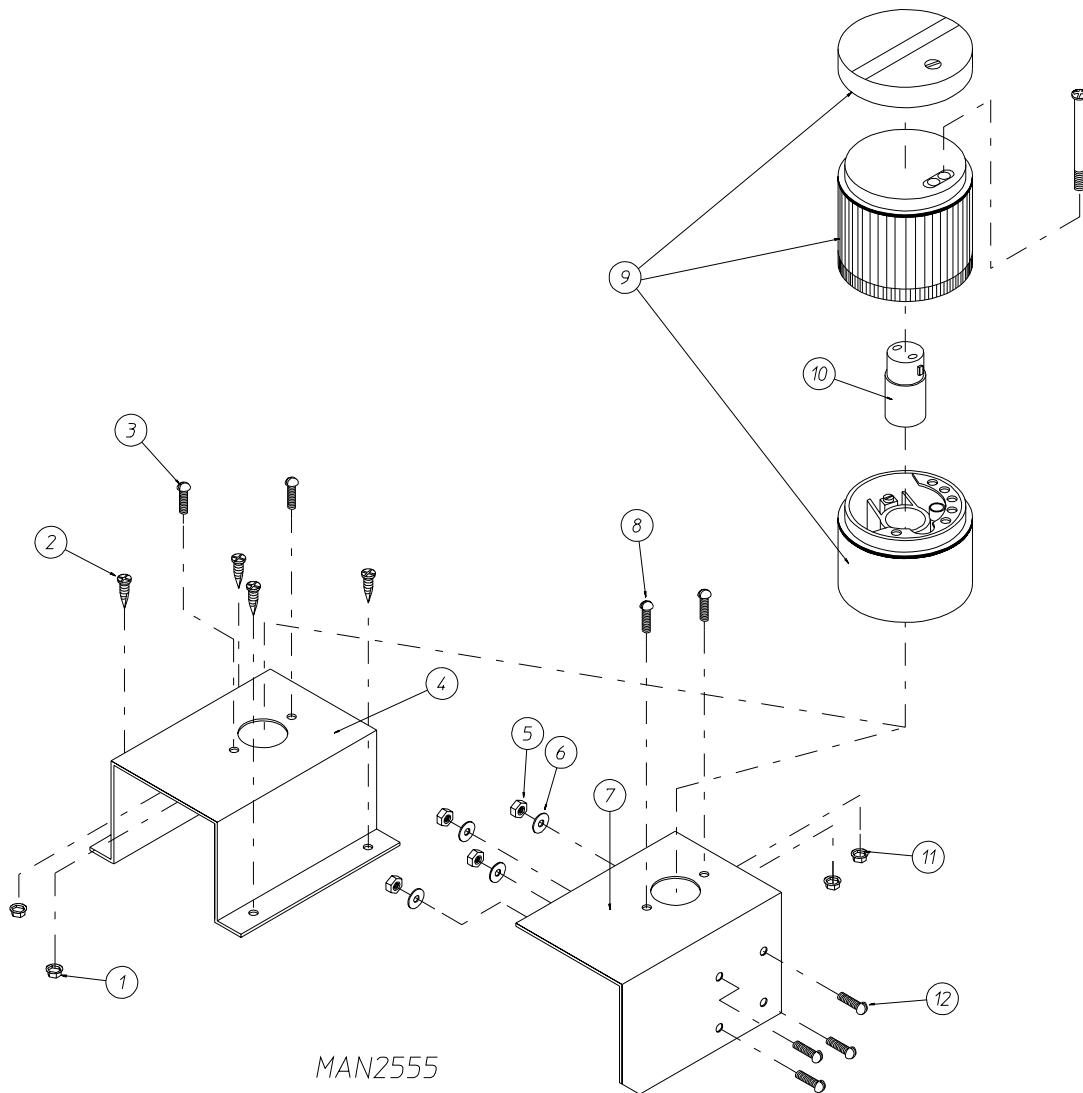

<u>Illus. No.</u>	<u>Part No.</u>	<u>Qty.</u>	<u>Description</u>
1	151001	2	#8-32 Pal Nut
2	150415	4	#10-16 x 1/2" Phillips Round Head Crimptite Screw
3	150108	2	#8-32 x 1/2" Phillips Pan Head Machine Screw
4*	821480	1	Cycle Light Bracket (for steam models Only)
5	152001	4	#8-32 Hex Nut
6	153012	4	#8 Star Washer
7*	332850	1	Cycle Light Bracket (for gas models Only)
8	150108	2	#8-32 x 1/2" Phillips Pan Head Machine Screw
9	123222	1	"Orange" Cycle Light
10	123221	1	Bulb - 24 VAC
11	151001	2	#8-32 Pal Nut
12	150108	4	#8-32 x 1/2" Phillips Pan Head Machine Screw

* Specify color when ordering.

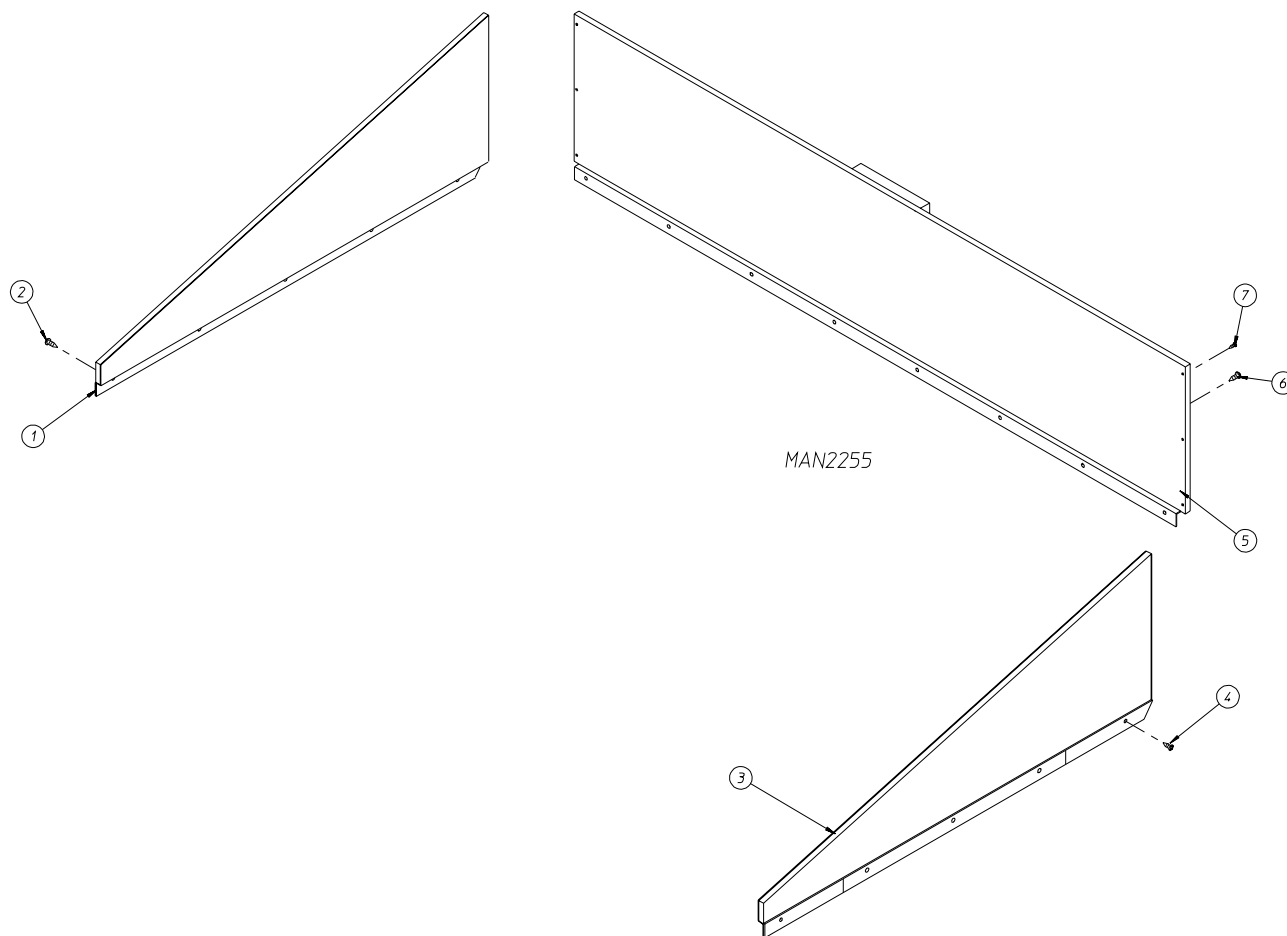

Illus. No.	Part No.	Qty.	Description
1*	881195	1	Forward Tilt Left Guard Assembly
2	150522	5	1/4-20 x 1/2" Hex Head TEK Screw
3*	881194	1	Forward Tilt Right Guard Assembly
4	150522	5	1/4-20 x 1/2" Hex Head TEK Screw
5*	881193	1	Forward Tilt Rear Guard Assembly
6	150522	9	1/4-20 x 1/2" Hex Head TEK Screw
7	150415	6	#10-16 x 1/2" Phillips Round Head Crimptite Screw

* Specify color when ordering.

2-WAY TILT

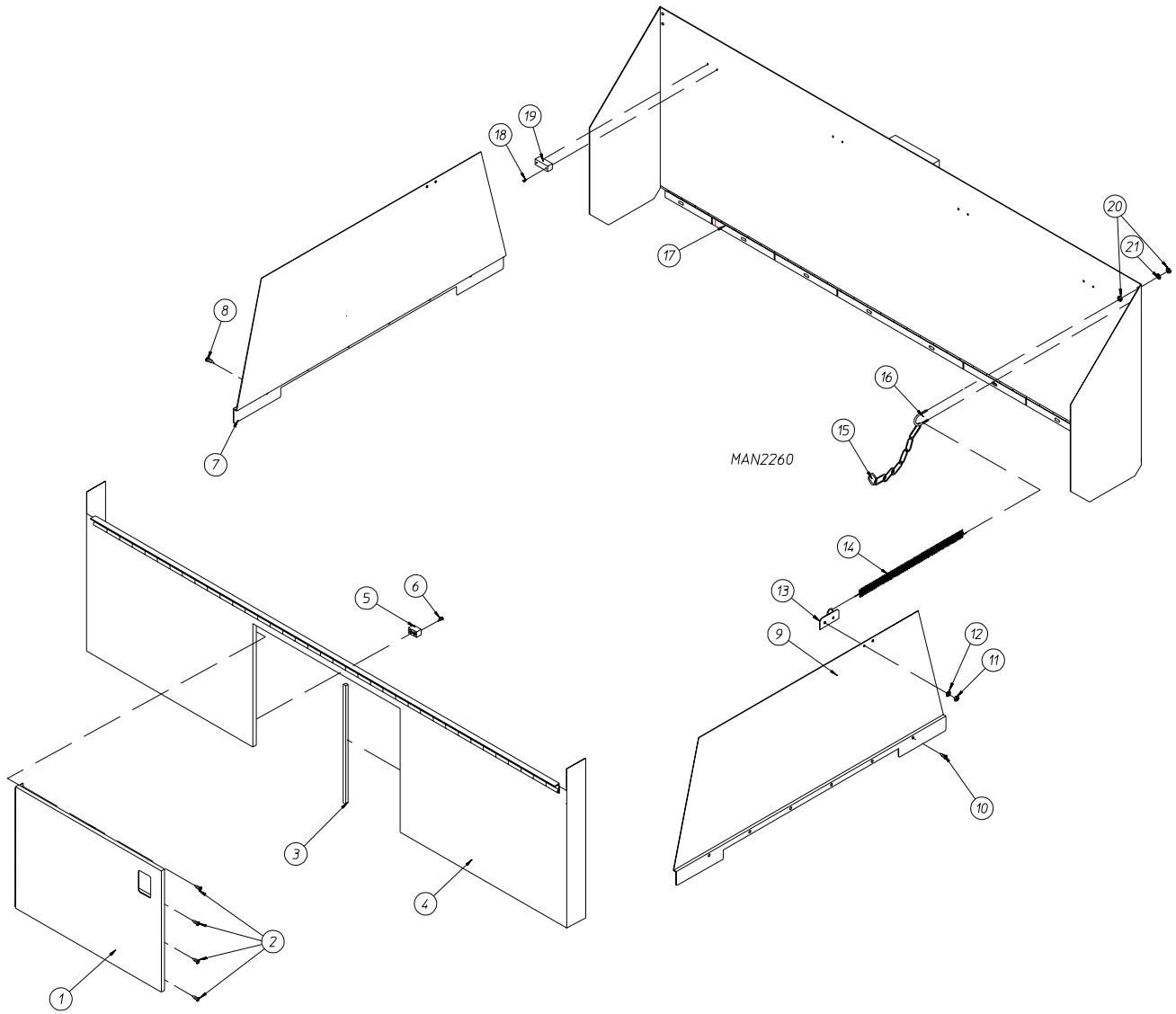

<u>Illus. No.</u>	<u>Part No.</u>	<u>Qty.</u>	<u>Description</u>
1*	881200	1	Front Guard Door ONLY
2	150300	4	#10 x 1/2" Hex Head TEK Screw
3*	170606	1	Door Magnet
4*	881199	1	Front Guard Panel ONLY (includes illus. nos. 3 through 6)
	881201	1	Front Guard Assembly Complete (includes illus. nos. 1 through 6)
5	170348	4	Front Guard Nylon Glide
6	150412	8	#10-16 x 3/4" Phillips Round Head Crimptite Screw
7*	881196	1	Side Shield Assembly
8	150522	6	1/4-20 x 1/2" Hex Head TEK Screw
9	881196	1	Side Shield Assembly
10*	150522	6	1/4-20 x 1/2" Hex Head TEK Screw
11	152002	4	1/4-20 Hex Nut
12	153007	4	1/4" Lock Washer
13	881188	2	Spring Catch Assembly
14	157014	2	Spring
15	108121	2	Rear Panel Chain
16	154354	2	3/4" Pipe U-Bolt
17*	881198	1	Rear Guard Assembly Complete (includes illus. nos. 15 through 21)
	881197	1	Rear Guard ONLY
18	150415	8	#10-16 x 1/2" Phillips Round Head Crimptite Screw
19	170345	4	Rear Guard Nylon Glide
20	152002	8	1/4-20 Hex Nut
21	153007	4	1/4" Lock Washer

* Specify color when ordering.

1-WAY TILT

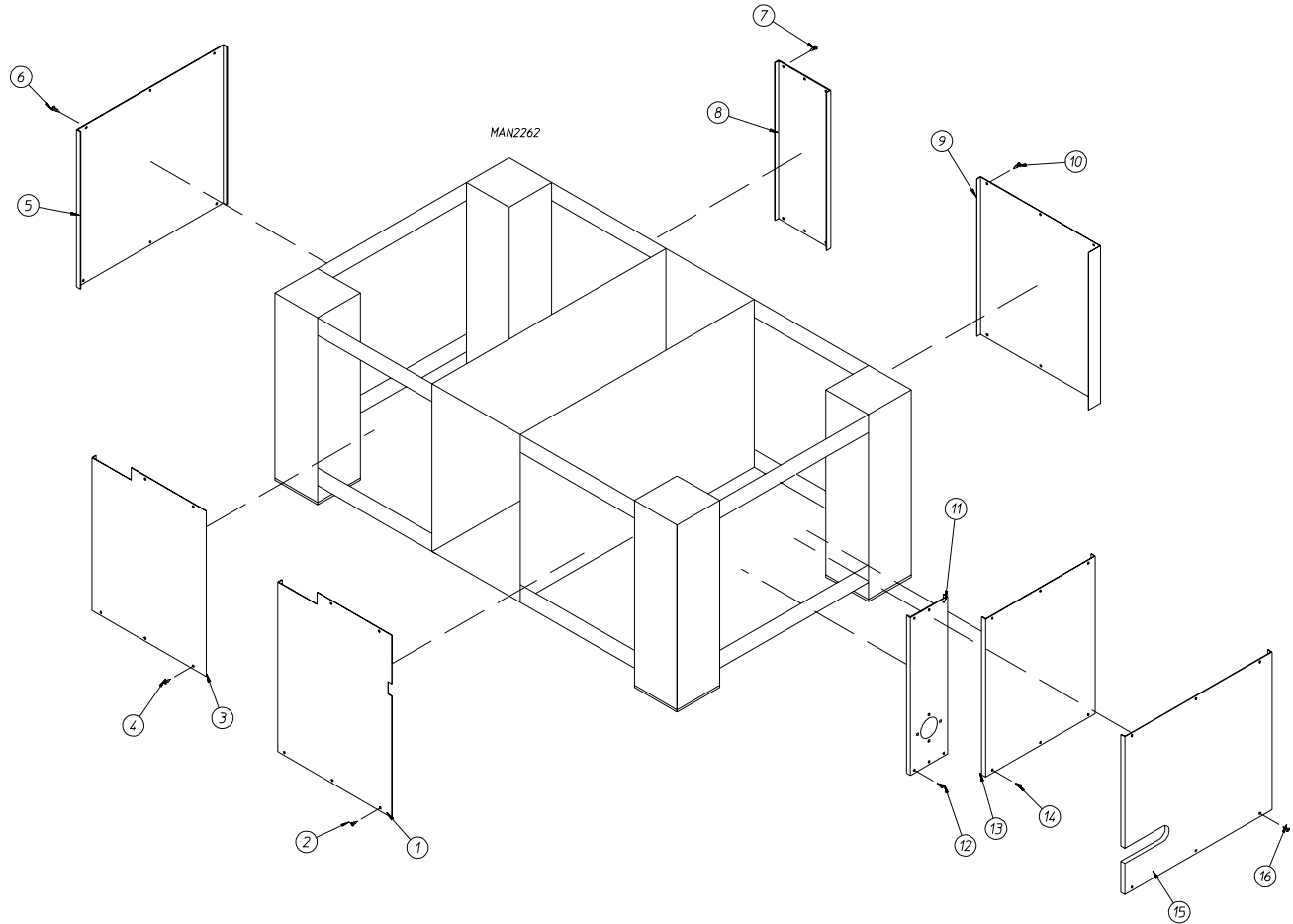

Illus. No.	Part No.	Qty.	Description
1*	332835	1	Front Right Base Panel
2	150522	6	1/4-20 x 1/2" Hex Head TEK Screw
3*	332834	1	Front Left Base Panel
4	150522	6	1/4-20 x 1/2" Hex Head TEK Screw
5*	332790	1	Left Side Base Panel
6	150522	6	1/4-20 x 1/2" Hex Head TEK Screw
7	150522	6	1/4-20 x 1/2" Hex Head TEK Screw
8*	332791	1	Rear Right Base Panel
9*	332738	1	Rear Left Base Panel
10	150522	6	1/4-20 x 1/2" Hex Head TEK Screw
11*	332788	1	Gas Inlet Base Panel (for gas models Only)
12	150522	6	1/4-20 x 1/2" Hex Head TEK Screw
13*	332789	1	Right Side Base Panel (for gas models Only)
14	150522	6	1/4-20 x 1/2" Hex Head TEK Screw
15*	332821	1	Right Side Base Panel (for steam models Only)
16	150522	6	1/4-20 x 1/2" Hex Head TEK Screw

* Specify color when ordering.

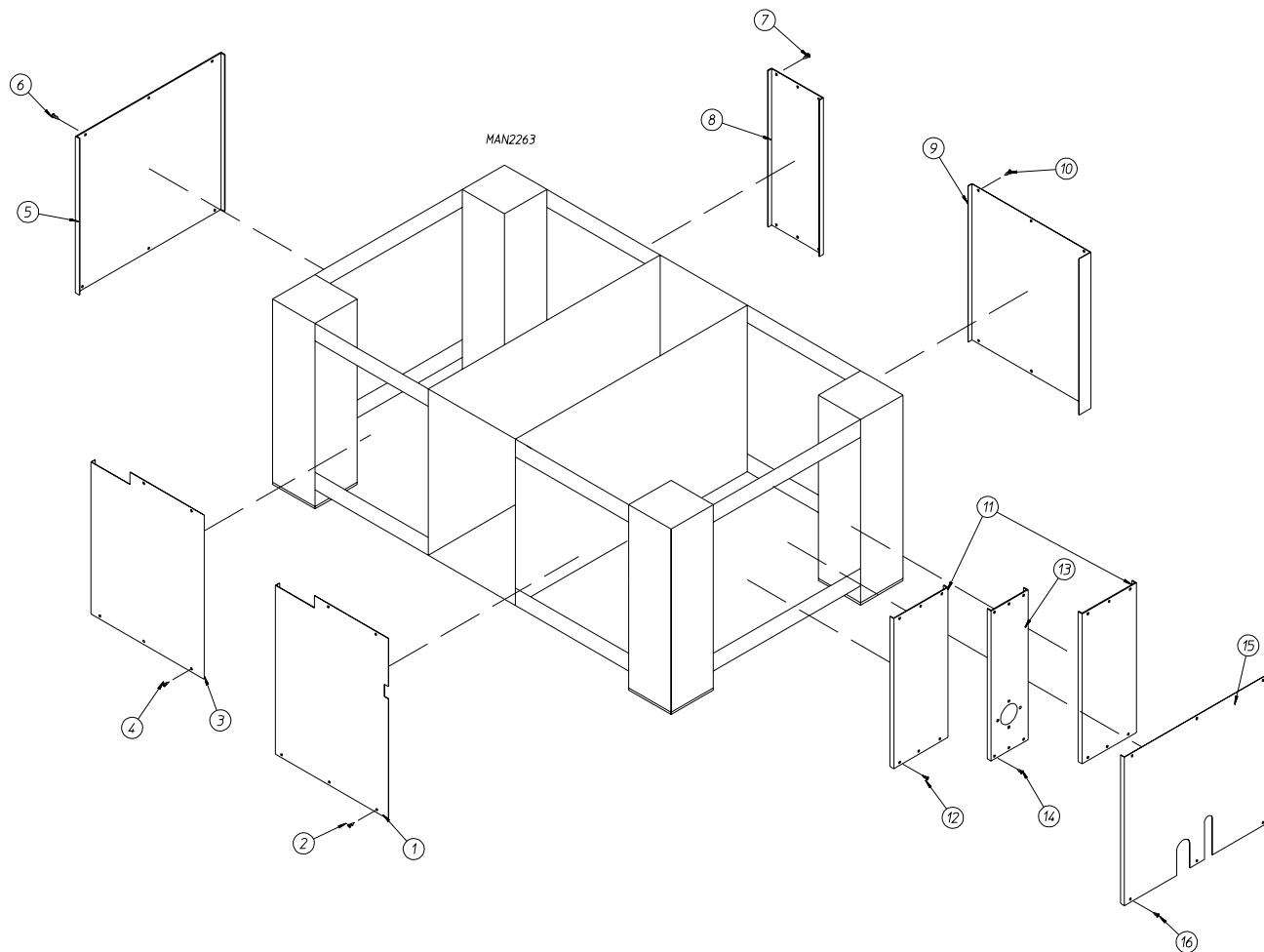

Illus. No.	Part No.	Qty.	Description
1*	332967	1	Front Base Panel
2	150522	6	1/4-20 x 1/2" Hex Head TEK Screw
3*	332967	1	Front Base Panel
4	150522	6	1/4-20 x 1/2" Hex Head TEK Screw
5*	332896	1	Left Side Base Panel
6	150522	6	1/4-20 x 1/2" Hex Head TEK Screw
7	150522	6	1/4-20 x 1/2" Hex Head TEK Screw
8*	332895	1	Right Rear Base Panel
9*	332968	1	Left Rear Base Panel
10	150522	6	1/4-20 x 1/2" Hex Head TEK Screw
11*	332970	2	Right Side Base Panel (for gas models Only)
12	150522	1	1/4-20 x 1/2" Hex Head TEK Screw
13*	332969	1	Gas Inlet Base Panel (for gas models Only)
14	150522	6	1/4-20 x 1/2" Hex Head TEK Screw
15*	332892	1	Right Side Base Panel (for steam models Only)
16	150522	6	1/4-20 x 1/2" Hex Head TEK Screw

* Specify color when ordering.

Selector Switch, Nameplate, and Mounting Base Chart

	Models with 2-Way Tilt Manual/Automatic Doors	Models with Foward Tilt and Manual Doors	Models with Foward Tilt and Automatic Doors	Models with Rear Tilt Manual/Automatic Doors
Illus. No. 13 Selector Switch	ADC Part No. 122348 3-Position Cam Selector Switch	ADC Part No. 122360 2-Position Switch	ADC Part No. 122348 3-Position Cam Selector Switch	ADC Part No. 122348 3-Position Cam Selector Switch
Illus. No. 14 Nameplate	ADC Part No. 122412 “Load-Dry-Unload”	ADC Part No. 122422 Unload “0-1”	ADC Part No. 122412 “Load-Dry-Unload”	ADC Part No. 122435 Load “Level-Off-Tilted”
Illus. No. 37 and Illus. No. 38 Mounting Base	Included with Selector Switch	ADC Part No. 132397 NO-NC Contact Block with Base	Included with Selector Switch	Included with Selector Switch

CONTROL PANEL FOR REAR RIGHT CONTROL DOOR

CHART FOR ITEM# 2	
MACHINE TYPE	SUB NEEDED
2 MANUAL DOOR, NON TILT	821809
2 MANUAL DOOR, FORWARD TILT	821586
2 MANUAL DOOR, REAR TILT	821586
2 MANUAL DOOR, 2 WAY TILT	821586
2 AUTO DOOR, NON TILT	821797
2 AUTO DOOR, FORWARD TILT	821807
2 AUTO DOOR, REAR TILT	821807
2 AUTO DOOR, 2 WAY TILT	821807

CONTROL PANEL FOR FRONT RIGHT CONTROL DOOR

CHART FOR ITEM# 2			
MACHINE TYPE	SUB NEEDED	MACHINE TYPE	SUB NEEDED
1 MANUAL DOOR, FORWARD TILT	821595	1 MANUAL DOOR, FORWARD TILT WITH SPRINKLER	821596
1 MANUAL DOOR, REAR TILT	821595	1 MANUAL DOOR, REAR TILT WITH SPRINKLER	821596
1 MANUAL DOOR, 2 WAY TILT	821595	1 MANUAL DOOR, 2 WAY TILT WITH SPRINKLER	821596
2 MANUAL DOOR, FORWARD TILT	821595	2 MANUAL DOOR, FORWARD TILT WITH SPRINKLER	821596
2 MANUAL DOOR, REAR TILT	821595	2 MANUAL DOOR, REAR TILT WITH SPRINKLER	821596
2 MANUAL DOOR, 2 WAY TILT	821595	2 MANUAL DOOR, 2 WAY TILT WITH SPRINKLER	821596
1 AUTO DOOR, NON TILT	821594	1 AUTO DOOR, NON TILT WITH SPRINKLER	821593
1 AUTO DOOR, FORWARD TILT	821595	1 AUTO DOOR, FORWARD TILT WITH SPRINKLER	832938
1 AUTO DOOR, REAR TILT	821595	1 AUTO DOOR, REAR TILT WITH SPRINKLER	832938
1 AUTO DOOR, 2 WAY TILT	821595	1 AUTO DOOR, 2 WAY TILT WITH SPRINKLER	832938
2 AUTO DOOR, NON TILT	821594	2 AUTO DOOR, NON TILT WITH SPRINKLER	821593
2 AUTO DOOR, FORWARD TILT	821595	2 AUTO DOOR, FORWARD TILT WITH SPRINKLER	821596
2 AUTO DOOR, REAR TILT	821595	2 AUTO DOOR, REAR TILT WITH SPRINKLER	821596
2 AUTO DOOR, 2 WAY TILT	821595	2 AUTO DOOR, 2 WAY TILT WITH SPRINKLER	821596
1 AUTO DOOR, FORWARD TILT WITH STEAM INJECTION	821836	RAR 06/13/00	MAN5305
1 AUTO DOOR, REAR TILT WITH STEAM INJECTION	821836		
1 AUTO DOOR, 2 WAY TILT WITH STEAM INJECTION	821836		
2 AUTO DOOR, NON TILT WITH STEAM INJECTION	821836		
2 AUTO DOOR, FORWARD TILT WITH STEAM INJECTION	821836		
2 AUTO DOOR, REAR TILT WITH STEAM INJECTION	821836		
2 AUTO DOOR, 2 WAY TILT WITH STEAM INJECTION	821836		

CHART FOR RIGHT HAND ELECTRICAL CONTROL PANEL

GAS MACHINE		TRANSFORMER (25)		CB7 (16)		CB6 (17)	
PSF #	VOLTAGE	QTY	P/N	QTY	P/N	QTY	P/N
TBD	190	---	TBD	---	TBD	1	135511
838108	208	1	132071 150VA	1	135512	1	135511
838109	220	1	132082 130VA	1	135512	1	135511
838110	230	1	132072 150VA	1	135512	1	135511
838111	240	1	132072 150VA	1	135512	1	135511
838112	380	1	132073 150VA	1	135512	1	135510
838113	400	1	132088 300VA	1	135513	1	135510
838114	416	1	132074 150VA	1	135512	1	135510
838115	460	1	132075 150VA	1	135512	1	135510
838116	480	1	132075 150VA	1	135512	1	135510
838117	575	1	132089 300VA	1	135513	1	135510
838118	600	1	132076 150VA	1	135512	1	135510
STEAM MACHINE		TRANSFORMER (25)		CB7 (16)		CB6 (17)	
PSF #	VOLTAGE	QTY	P/N	QTY	P/N	QTY	P/N
TBD	190	---	TBD	X	TBD	1	135511
838119	208	1	132087 300VA	1	135513	1	135511
TBD	220	---	TBD	X	TBD	1	135511
838120	230	1	132087 300VA	1	135513	1	135511
838121	240	1	132087 300VA	1	135513	1	135511
838122	380	1	132073 150VA	1	135512	1	135510
838123	400	1	132088 300VA	1	135513	1	135510
838124	416	1	132074 150VA	1	135512	1	135510
838125	460	1	132075 150VA	1	135512	1	135510
838126	480	1	132075 150VA	1	135512	1	135510
838127	575	1	132089 150VA	1	135512	1	135510
838128	600	1	132076 150VA	1	135512	1	135510

SL 05/22/00

MAN5306

