

Published Manual Number/ECN: MAP30C4EAE/2006296A

- Publishing System: TPAS
- Access date: 7/21/2006
- Document ECN's: Latest Available



Service—

30015/30022 C4E



**Read the
separate
safety
manual
before
installing,
operating,
or servicing**

Please Read

About the Manual Identifying Information on the Cover

The front cover displays pertinent identifying information for this manual. Most important, are the published manual number (part number) /ECN (date code). Generally, when a replacement manual is furnished, it will have the same published manual number, but the latest available ECN. This provides the user with the latest information applicable to his machine. Similarly all documents comprising the manual will be the latest available as of the date the manual was printed, **even though older ECN dates for those documents may be listed in the table of contents.**

When communicating with the Milnor factory regarding this manual, please also provide the other identifying information shown on the cover, including the publishing system, access date, and whether the document ECN's are the latest available or exact.

References to Yellow Troubleshooting Pages

This manual may contain references to "yellow pages." Although the pages containing troubleshooting procedures are no longer printed on yellow paper, troubleshooting instructions, if any, will be contained in the easily located "Troubleshooting" chapter or section. See the table of contents.

Trademarks of Pellerin Milnor Corporation

The following, some of which may be used in this manual, are trademarks of Pellerin Milnor Corporation:

Ampsaver [®]	Dye-Extractor [®]	Gear Guardian [®]	Milnet [®]	Staph-Guard [®]
Autolint [®]	Dyextractor [®]	Hands-Off [®]	Milnor [®]	System 4 [®]
Auto-Purge [®]	E-P Express [®]	Hydro-Cushion [®]	Miltrac	System 7 [®]
Autovac	E-P OneTouch [®]	Mildata [®]	Miltron	Totaltrol [®]
CBW [®]	E-P Plus [®]			

Comments and Suggestions

Help us to improve this manual by sending your comments to:

Pellerin Milnor Corporation
Attn: Technical Publications
P. O. Box 400
Kenner, LA 70063-0400

Fax: (504) 469-1849

Table of Contents

for MAP30C4EAE/2006296A

30015/30022 C4E

Page	Description	Document/ECN
1	About This Manual	MHP30RM1AE/9541AV
3	Warranty	BMP720097/92732A
5	How to Order Parts	BMP720097R/72332A
6	Guards & Covers	BMP020067/2002512V
8	About the Forces Transmitted by Milnor Washer-Extractors	BIWUUI02/20001108
10	Glossary of Tag Illustrations-30" G, T and V style WE	MSIUUMTGAE/2004072V
15	Avoiding Damage from Allied Remote Chemical Delivery Systems	BIWUUI03/20030306
21	Section 1: Service and Maintenance	
22	Preventive Maintenance	BIRQUM01/20050302
26	Fastener Torque Requirements	MSSM0101CE/9906AV
45	Section 2: Drive Assemblies	
46	Drive Chart	BMP020055/2002446V
47	Motor Mount	BMP020053/2002446V
49	Clutch Brake	BMP020054/2004103V
51	Section 3: Bearing Assemblies	
52	Replacing Main Bearings and Seals on 30015, 30020, 30022Cxx, Kxx, Sxx, and Mxx Models	MSSM0708BE/9846AV
59	Cylinder, Shell, Bearing, and Console	BMP020001/2002446V
61	Main Bearing Assembly 30015C4A, C4T, C4E, M4x, K5x, S5x	BMP910032/2002446V
63	Main Bearing Assembly 30020 & 30022	BMP910033/2002446V
65	Section 4: Shell and Door Assemblies	
66	Shellfront Assembly, Conduit, & Interlock	BMP920024/2004055V
68	Door Assembly	BMP020002/2004055V
70	Interlock Assembly	BMP020058/2005086V
75	Section 5: Control and Sensing	
76	Switch Panel Assembly	BMP020068/2004055V
78	Coin Acceptor and Vault	BMP020061/2003276V
80	Vibration Safety Switch Adjustments	MSSMA408BE/9273BV
82	Vibration Safety Switch	BMP910038/2006155B
83	Section 6: Chemical Supply	
84	Soap Chute Installation	BMP000040/2004055V
85	Section 7: Water and Drain	
86	Schematic Symbols Key	BMP920008/2000302V
87	Water Schematic	BMP020062/2002446V
88	Water Inlet	BMP020056/2003215V
90	Level Switches	BMP020060/2002446V

Table of Contents, cont.

Page	Description	Document/ECN
91	Drain Sump Installation	BMP920014/2004055V
92	Drain Valve Installation	BMP020057/2004055V
94	3" Electric Drain Valve	BMP920017/2006214B

ABOUT THIS MANUAL

Scope—This instruction manual is intended to provide preventive maintenance procedures, service procedures, and mechanical parts identification for all Milnor[®] 30015, 30020, and 30022 model rigid mount washer-extractors. Measurements are in commonly used US and metric units unless otherwise noted.

See the appropriate programming, operating, and troubleshooting manual for information on the control system. See the schematic manual for electrical parts identification and electrical troubleshooting.

Manual Number/Date Code (When To Discard or Save)—The manual number/date code is located on the inside front cover, upper right corner just above the manual name. Whenever the manual is reprinted with new information, part of this number changes. **If the date code after the “/” changes, the new version applies to all machines covered by the old version, but is improved— thus the old version can be discarded. If the manual number before the “/” changes, the new manual covers only new machines.** Example: Discard MATMODELAE/8739CV when MATMODELAE/8739DV is received (minor improvements). Also, discard MATMODELAE/8739DV when MATMODELAE/8746AV is received (major improvements). But keep MATMODELAE/8746FV when MATMODELBE/8815AV is received, since the new manual no longer applies to machines originally shipped with the old manual.

Documents and Change Bars—The individual documents comprising this manual use the same revision criteria as the manual. Text documents also display change bars. Example: When section MSOP0599AE/9135BV becomes MSOP0599AE/9135CV, change bars with the letter “C” appear next to all changes for this revision. For a major rewrite (e.g., MSOP0599AE/9226AV), all change bars are deleted.

For Assistance—Please call:

Trademarks of Pellerin Milnor Corporation—The following, some of which may be used in this publication, are trademarks of Pellerin Milnor Corporation:

Ampsaver [®]	CBW [®]	Gear Guardian [®]	Milnet [®]	Staph-Guard [®]
Autolint [®]	Dye-Extractor [®]	Hands-Off [®]	Milnor [®]	System 4 [®]
Auto-Purge [®]	Dyextractor [®]	Hydro-Cushion [®]	Miltrac	System 7 [®]
Autovac	E-P Plus [®]	Mildata [®]	Miltron	Totaltrol [®]

PELLERIN MILNOR CORPORATION

LIMITED STANDARD WARRANTY

We warrant to the original purchaser that MILNOR machines including electronic hardware/software (hereafter referred to as "equipment"), will be free from defects in material and workmanship for a period of one year from the date of shipment from our factory with no operating hour limitation. This warranty is contingent upon the equipment being installed, operated and serviced as specified in the operating manual supplied with the equipment, and operated under normal conditions by competent operators.

Providing we receive written notification of a warranted defect within 30 days of its discovery, we will – at our option – repair or replace the defective part or parts, FOB our factory. We retain the right to require inspection of the parts claimed defective in our factory prior to repairing or replacing same. We will not be responsible, or in any way liable, for unauthorized repairs or service to our equipment, and this warranty shall be void if the equipment is repaired or altered in any way without MILNOR's written consent.

Parts which require routine replacement due to normal wear – such as gaskets, contact points, brake and clutch linings and similar parts – are not covered by this warranty, nor are parts damaged by exposure to weather or to chemicals.

We reserve the right to make changes in the design and/or construction of our equipment (including purchased components) without obligation to change any equipment previously supplied.

ANY SALE OR FURNISHING OF ANY EQUIPMENT BY MILNOR IS MADE ONLY UPON THE EXPRESS UNDERSTANDING THAT MILNOR MAKES NO EXPRESSED OR IMPLIED WARRANTIES OF MERCHANTABILITY OR FITNESS FOR ANY PARTICULAR USE OR PURPOSE. MILNOR WILL NOT BE RESPONSIBLE FOR ANY COSTS OR DAMAGES ACTUALLY INCURRED OR REQUIRED AS A RESULT OF: THE FAILURE OF ANY OTHER PERSON OR ENTITY TO PERFORM ITS RESPONSIBILITIES, FIRE OR OTHER HAZARD, ACCIDENT, IMPROPER STORAGE, MISUSE, NEGLIGENCE, POWER OR ENVIRONMENTAL CONTROL MALFUNCTIONS, DAMAGE FROM LIQUIDS, OR ANY OTHER CAUSE BEYOND THE NORMAL RANGE OF USE. REGARDLESS OF HOW CAUSED, IN NO EVENT SHALL MILNOR BE LIABLE FOR SPECIAL, INDIRECT, PUNITIVE, LIQUIDATED, OR CONSEQUENTIAL COSTS OR DAMAGES, OR ANY COSTS OR DAMAGES WHATSOEVER WHICH EXCEED THE PRICE PAID TO MILNOR FOR THE EQUIPMENT IT SELLS OR FURNISHES.

WE NEITHER ASSUME, NOR AUTHORIZE ANY EMPLOYEE OR OTHER PERSON TO ASSUME FOR US, ANY OTHER RESPONSIBILITY AND/OR LIABILITY IN CONNECTION WITH THE SALE OR FURNISHING OF OUR EQUIPMENT TO ANY BUYER.

BMP720097
92732A

How to order repair parts

Repair parts may be ordered either from the authorized dealer who sold you this machine, or directly from the MILNOR factory. In most cases, your dealer will have these parts in stock.

When ordering parts, please be sure to give us the following information:

1. Model and serial number of the machine for which the parts are required
2. Part number
3. Name of the part
4. Quantity needed
5. Method of shipment desired
6. In correspondence regarding motors or electrical controls, please include all nameplate data, including wiring diagram number and the make or manufacturer of the motor or controls.

All parts will be shipped C.O.D. transportation charges collect only.

Please read this manual

It is strongly recommended that you read the installation and operating manual before attempting to install or operate your machine. We suggest that this manual be kept in your business office so that it will not become lost.

PELLERIN MILNOR CORPORATION

P.O. BOX 400, KENNER, LA., 70063-0400, U.S.A.

FAX: Administration 504/468-9307, Engineering 504/469-1849, Service 504/469-9777

BMP720097R
72332A

Guards & Covers
30015 & 30022C4E

BMP020067/2002512V
(Sheet 1 of 2)



Pellerin Milnor Corporation
P. O. Box 400, Kenner, LA 70063-0400

Litho in U.S.A.

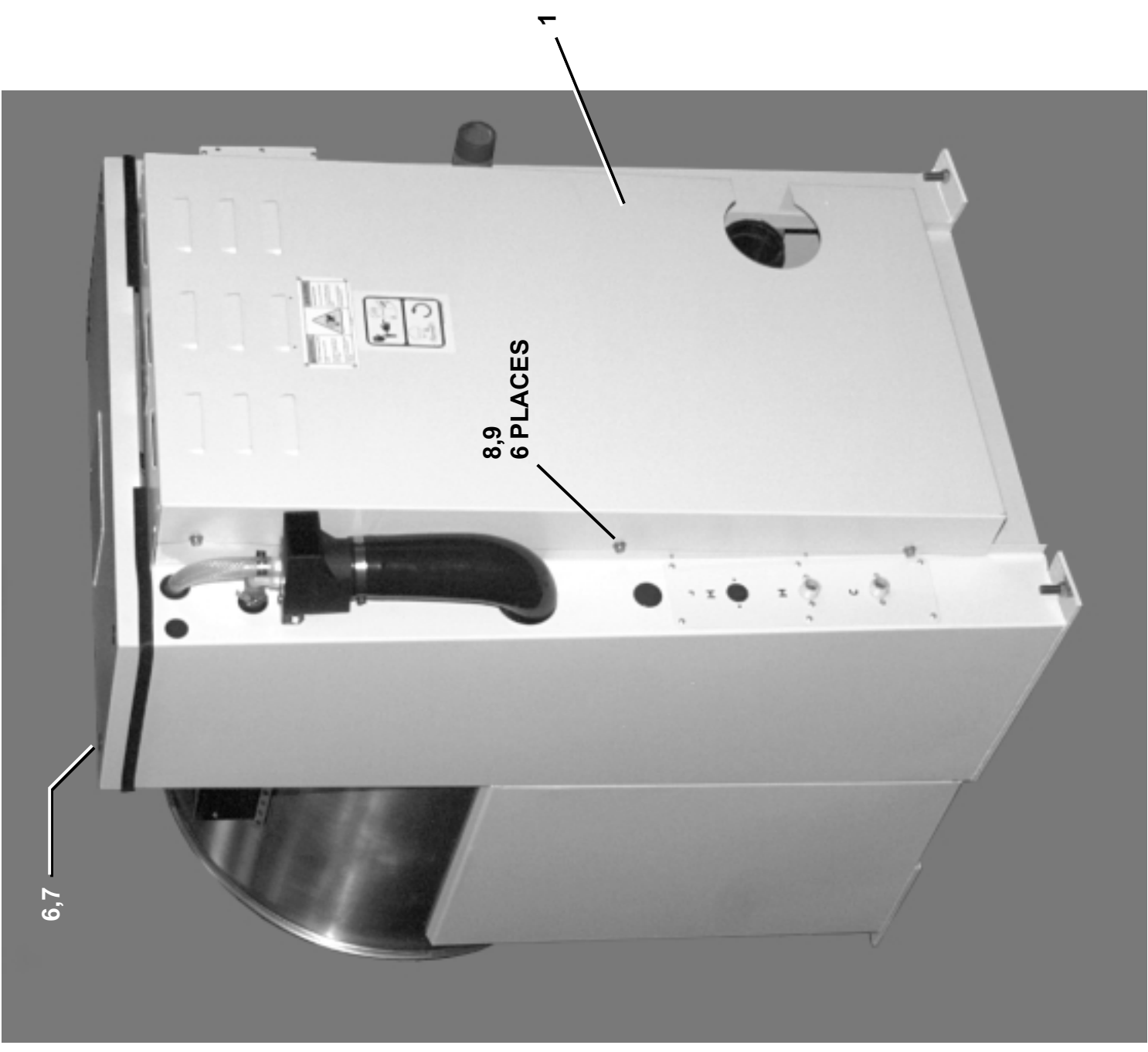

Guards & Covers 30015 & 30022C4E

BMP020067/2002512V
(Sheet 2 of 2)



Pellerin Milnor Corporation
P. O. Box 400, Kenner, LA 70063-0400

Litho in U.S.A.

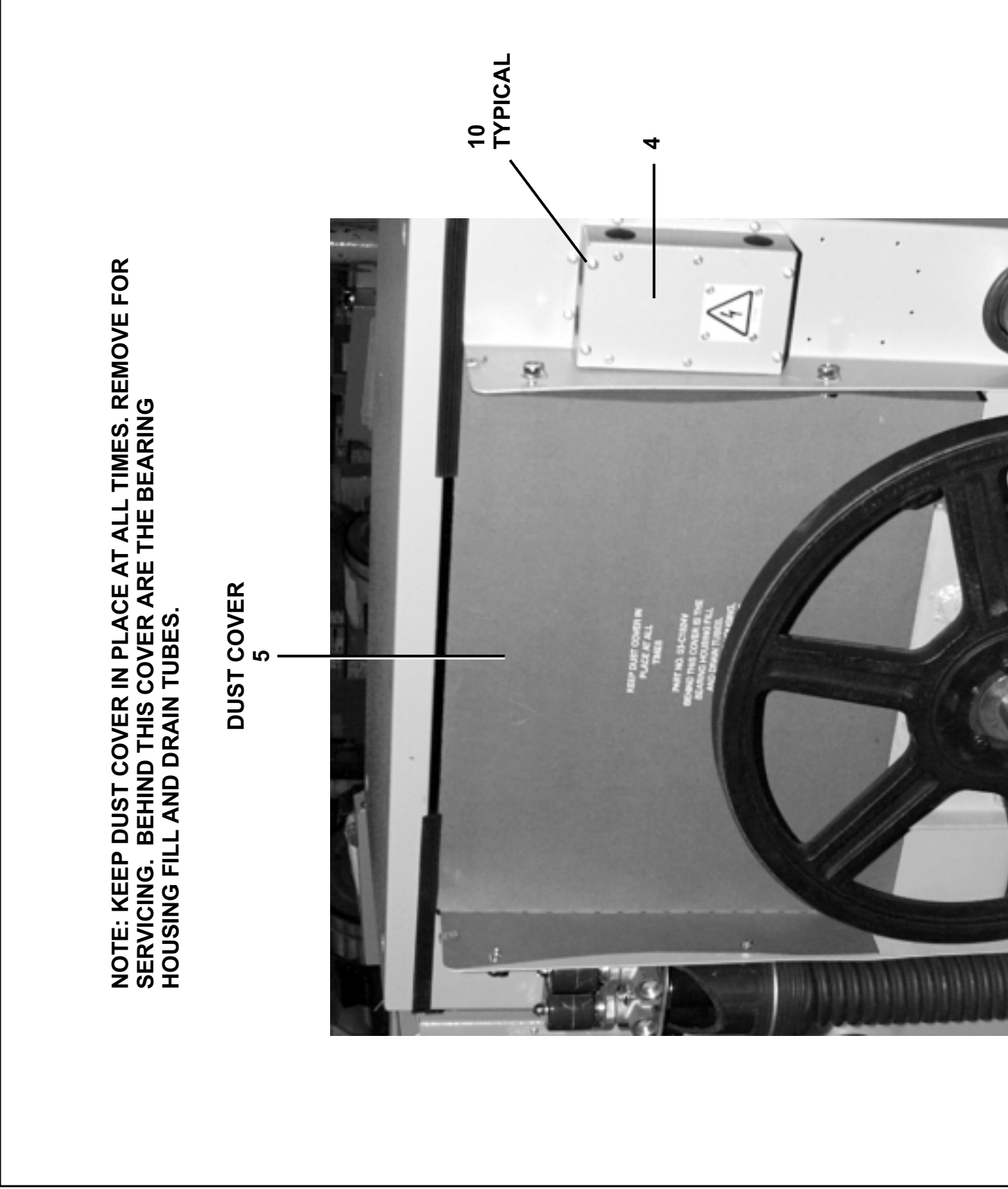

NOTE: KEEP DUST COVER IN PLACE AT ALL TIMES. REMOVE FOR SERVICING. BEHIND THIS COVER ARE THE BEARING HOUSING FILL AND DRAIN TUBES.

DUST COVER
5

10
TYPICAL

4

Used In	Item	Part Number	Description	Comments
			ASSEMBLIES	
A		GGC30001	GUARDS/COVERS INSTALL	
B		ASC30001	3022C4E FRONT/REAR CONSOLE ASY	
			COMPONENTS	
all	1	02 03497B	GUARD REAR BELT FULL	
all	2	W2 03699A	*CONSOLE TOP WELDMENT	
all	3	02 03344	TRIM=REAR CONSOLE TOP 7FT/PC	
all	4	03 C4X7	COVER:SYSTEM 7 LIQUID SUPPLY	
all	5	03 C1824V	DUST COVER-30"V6J BELT	
all	6	15K120	HXCAPSCR 3/8-16UNC2AX2 GR5 ZIN	
all	7	17N070P	RETAIN NUT 3/8-16 #S10100-27	
all	8	15P200	TRDCUT-F HXWASHD 3/8-16X3/4NIK	
all	9	15U346	FLAWASH 7/8X3/8X.030 NATURAL N	
all	10	15P185	TRDCUT-F HXHD 1/4-20UNC2AX3/4	

Parts List- Guards & Covers
Find the correct assembly first, then find the needed components. The item letters (A, B, C, etc.) assigned to assemblies are referred to in the "Used In" column to identify which components belong to an assembly. The item numbers (1, 2, 3, etc.) assigned to components relate the parts list to the illustration.

About the Forces Transmitted by Milnor® Washer-extractors

Document BIWUUI02
Specified Date 20001108
As-of Date 20001108
Access Date 20001108

Applicability.....WUU

During washing and extracting, all washer-extractors transmit both static and dynamic (cyclic) forces to the floor, foundation, or any other supporting structure. During washing, the impact of the goods as they drop imparts forces which are quite difficult to quantify. Size for size, both rigid and flexibly-mounted machines transmit approximately the same forces during washing. During extracting, rigid machines transmit forces up to 30 times greater than equivalent flexibly-mounted models. The actual magnitude of these forces vary according to several factors:

- machine size,
- final extraction speed,
- amount, condition, and type of goods being processed,
- the liquor level and chemical conditions in the bath preceding extraction, and
- other miscellaneous factors.

Estimates of the maximum force normally encountered are available for each Milnor® model and size upon request. Floor or foundation sizes shown on any Milnor® document are only for on-grade situations based only on previous experience without implying any warranty, obligation, or responsibility on our part.

1. Rigid Machines

Size for size, rigid washer-extractors naturally require a stronger, more rigid floor, foundation, or other supporting structure than flexibly-mounted models. If the supporting soil under the slab is itself strong and rigid enough and has not subsided to leave the floor slab suspended without support, on grade installations can often be made directly to an existing floor slab if it has enough strength and rigidity to safely withstand our published forces without transmitting undue vibration. If the subsoil has subsided, or if the floor slab itself has insufficient strength and rigidity, a deeper foundation, poured as to become monolithic with the floor slab, may be required. Support pilings may even be required if the subsoil itself is “springy” (i.e., if its resonant frequency is near the operating speed of the machine). Above-grade installations of rigid machines also require a sufficiently strong and rigid floor or other supporting structure as described below.

2. Flexibly-mounted Machines

Size for size, flexibly-mounted machines generally do not require as strong a floor, foundation, or other supporting structure as do rigid machines. However, a floor or other supporting structure having sufficient strength and rigidity, as described in section 3, is nonetheless vitally important for these models as well.

3. How Strong and Rigid?

Many building codes in the U.S.A. specify that laundry floors must have a minimum live load capacity of 150 pounds per square foot (732 kilograms per square meter). However, even compliance with this or any other standard does not necessarily guarantee sufficient rigidity. In any event, it is the sole responsibility of the owner/user to assure that the floor and/or any other supporting structure exceeds not only all applicable building codes, but also that the floor and/or any other supporting structure for each washer-extractor or group of washer-extractors actually

has sufficient strength and rigidity, plus a reasonable factor of safety for both, to support the weight of all the fully loaded machine(s) including the weight of the water and goods, and including the published 360° rotating sinusoidal RMS forces that are transmitted by the machine(s). Moreover, the floor, foundation, or other supporting structure must have sufficient rigidity (i.e., a natural or resonant frequency many times greater than the machine speed with a reasonable factor of safety); otherwise, the mentioned 360° rotating sinusoidal RMS forces can be multiplied and magnified many times. It is especially important to consider all potential vibration problems that might occur due to all possible combinations of forcing frequencies (rotating speeds) of the machine(s) compared to the natural frequencies of the floor and/or any other supporting structure(s). A qualified soil and/or structural engineer must be engaged for this purpose.

Figure 1: How Rotating Forces Act on the Foundation

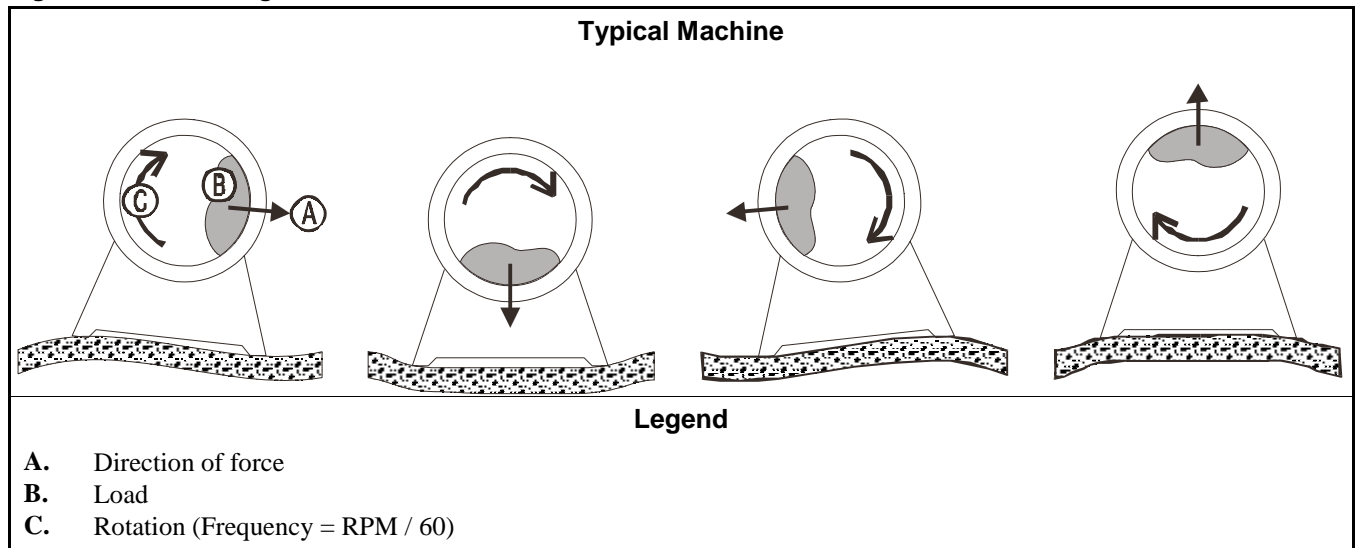
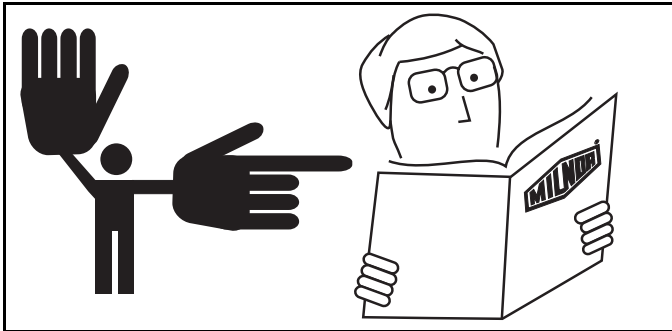
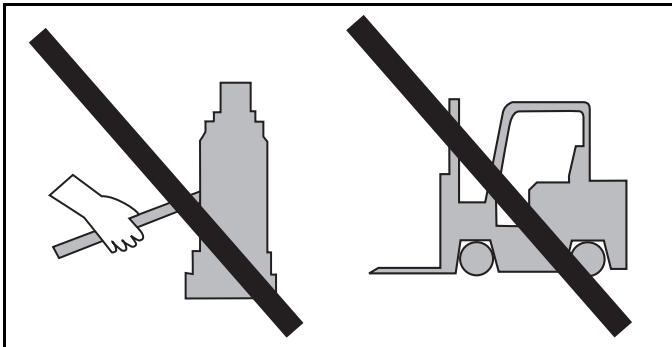
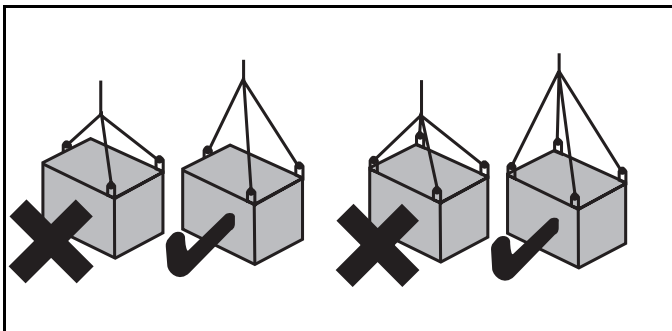
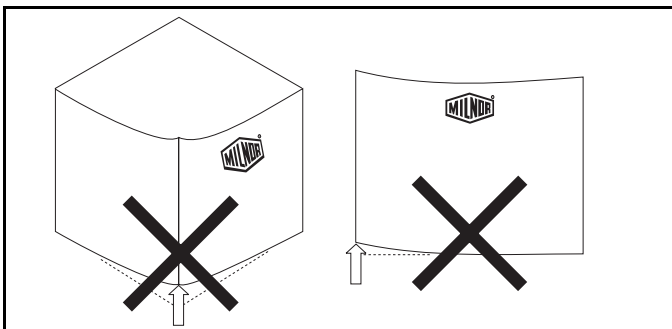

Figure 1 above is intended to depict both on-grade and above-grade installations and is equally applicable to flexibly-mounted washer-extractors, as well as to rigid models installed either directly on a floor slab or on a foundation poured integrally with the slab. Current machine data is available from Milnor® upon request. All data is subject to change without notice and may have changed since last printed. It is the sole responsibility of every potential owner to obtain written confirmation that any data furnished by Milnor® applies for the model(s) and serial number(s) of the specific machines.

Glossary of Tag Illustrations— G-Style, 30" T-Style, & 30" V-Style Washer-Extractors

MSIUUMTGAE/2004072V

Illustration	Explanation
	Stop! Read the manual first for complete instructions before continuing.
	Do not jack the machine here. Do not lift the machine here.
	Use three point or four point lifting as determined by the lifting eyes furnished. Rig the load using lifting cables of sufficient size and length to ensure cables are not over-stressed.
	Do not lift the machine from one corner or one side edge.

Illustration

Explanation

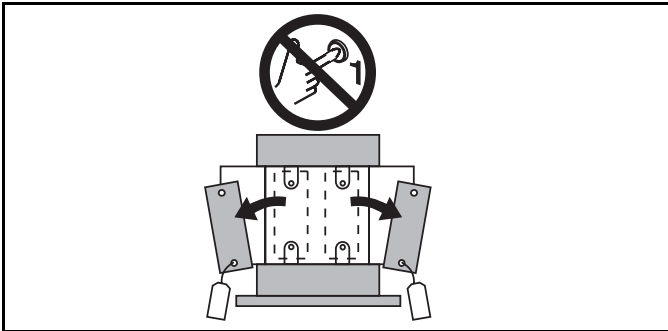

Do not start this machine until the packing materials, lifting brackets, etc. with this tag attached or behind this panel are removed. These materials are painted red. Safety stands or brackets (also painted red) may be provided with this machine. Do not discard safety stands or brackets



This motor or pump should rotate in the direction of the arrow.

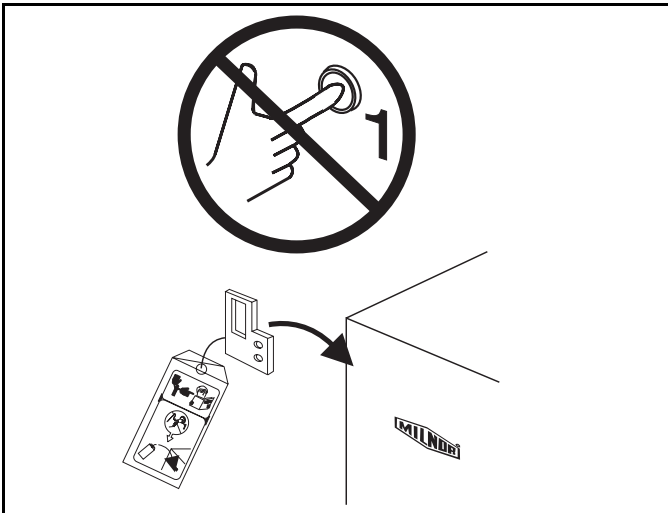

Do not start this machine until the part with this tag is installed on the machine.

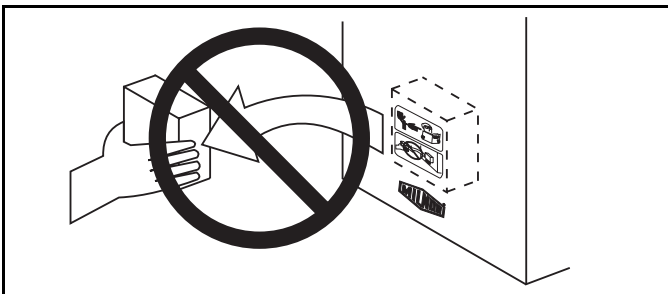

Do not remove this component from the machine.

Illustration

Explanation

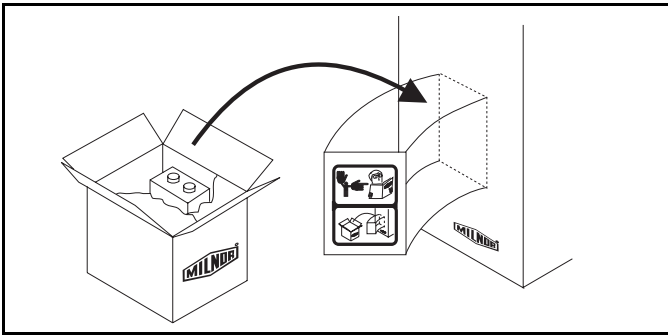

Install the appropriate part here before operating the machine.

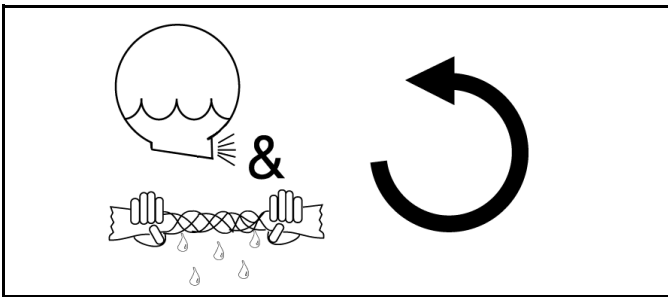

During drain and extract, the cylinder must rotate counterclockwise when viewed from here (rear of machine).

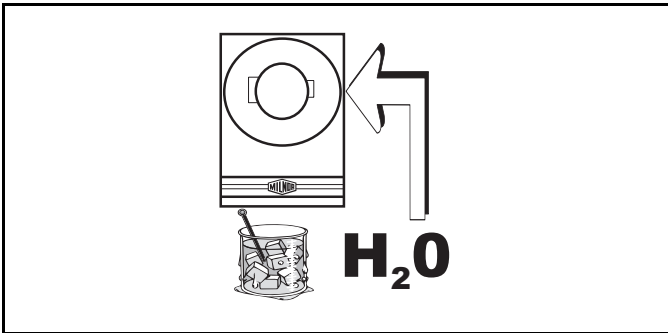

Make cold water connection here.

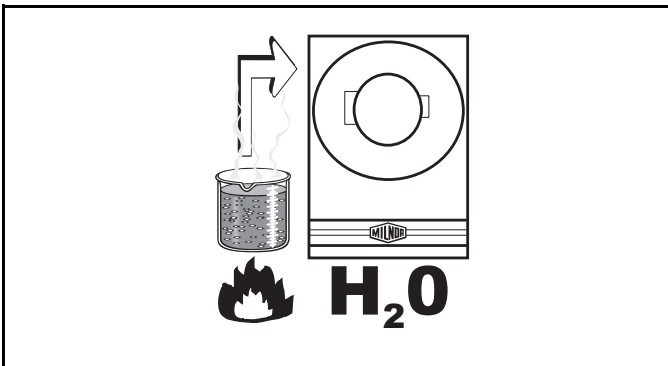

Make hot water connection here.

Illustration

Explanation

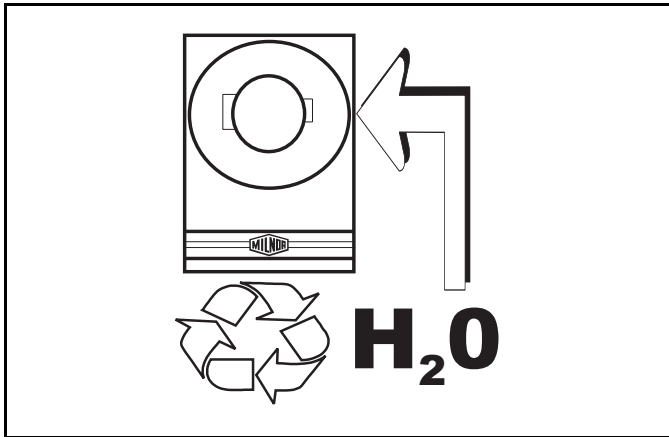

Make third (reuse) water connection here.

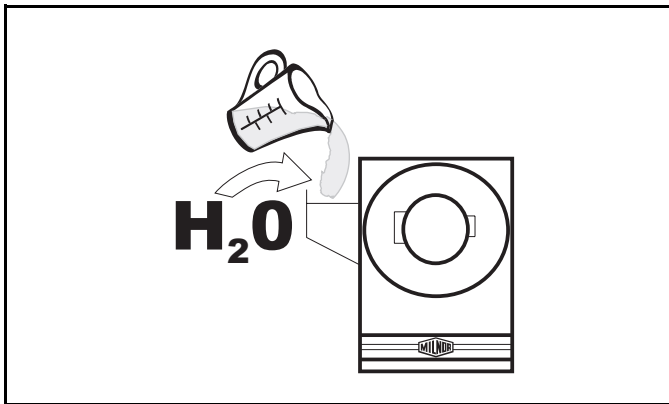

Make flushing water connection here.

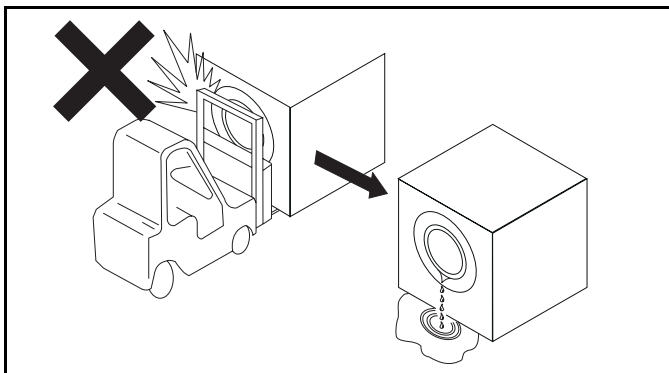

Do not strike shell front of washer-extractors during fork lifting. Striking shell front will cause door to leak.



Water hammer will rupture the water inlet valves on this machine. Eliminate water hammer on waterlines to this machine. Follow all applicable codes when installing water hammer arresters on water lines.

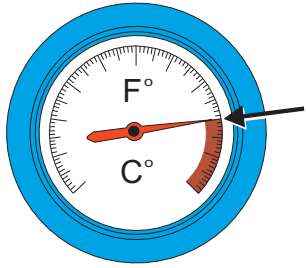

$\leq 160 \text{ F}^\circ$

$\leq 71 \text{ C}^\circ$

Excessive water temperature will damage valves. Do not exceed 160 degrees Fahrenheit (71 degrees Celsius).

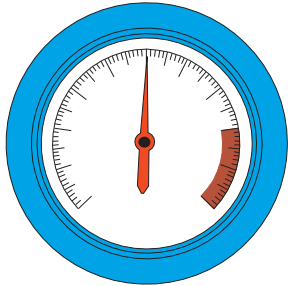

10 - 75 psi

0.7 - 5.1 bar

Excessive air pressure will damage valves. Do not exceed 80 psi (5.5 bar).

Avoiding Damage From Allied Remote Chemical Delivery Systems

Milnor® does not manufacture or supply remote chemical delivery systems and this document is meant only to illustrate some of the possible problems that can be minimized during installation of such systems by the chemical supply company. Milnor washer-extractors and CBW® batch washers (tunnels) are available with convenient inlets for such systems (see Figure 1). Most common of the types of systems currently used in commercial laundering operations are pumped chemical systems. Other types, such as constant pressure, re-circulating ring main systems have also been, and may continue to be used with Milnor equipment.

This document warns about some of the possible hazards posed by chemical systems and lists certain requirements needed to minimize those hazards. The procedures for interfacing with allied chemical systems and information pertinent to chemical use in general are provided elsewhere in the product manuals (see Note 1).

Figure 1: Pumped Chemical Inlets on CBW Batch Washer



Note 1: Misuse of laundering chemicals (such as injecting excessive concentrations of chlorine bleach or permitting acid sours to react with hypo chlorite) due to incorrect formulation can also be hazardous. Information pertinent to chemical use is provided elsewhere in the product manuals.

1. How a Chemical System Can Damage the Machine It Serves

Milnor has manufactured washer-extractors and tunnel washers with the same stainless steel specification since its founding. Every batch of steel used is certified and documented by the steel mill. Testing of samples damaged by corrosion have, in every case, proven the steel to be well within the AISI 304 specification.

Chemical products commonly found in the laundry industry, when used in **established** dosages and proper operating parameters, under the auspices of an experienced chemical specialist, should produce satisfactory results, with no consequential detrimental effects. The industry has published standards in Riggs and Sherrill, “Textile Laundering Technology”. However, the stainless steel can be damaged and even destroyed by **abnormal** contact with chlorine bleach, hydrofluosilicic acid and other commonly used chemicals, as will occur if chemicals are unintentionally leaked into the machine, particularly when it is no longer in use and especially when machine surfaces are dry.

Some chemical systems have been found to permit chemicals to dribble from the supply lines, or worse, to siphon from the supply tank into the machine, during operation and long after the system is shut down—as after working hours and during weekends. If this occurs, **deterioration (rusting) of the stainless steel and damage to any textiles therein will inevitably result. If this condition goes undetected, machine damage is likely to be catastrophic.** No machine is immune to such damage.



CAUTION [1]: Equipment and Textile Damage Hazards—Chemicals leaked into the machine, particularly when it is idle can destroy machine components and textiles left in the machine. **Pellerin Milnor Corporation accepts absolutely no responsibility for damage to its equipment or to textiles therein from abnormal contact with chemicals.**

- Ensure that the chemical system prevents unintentional release of chemicals.
- Inspect regularly for proper operation and evidence of damage.

2. Requirements for Chemical Systems Used With Milnor Machines

It is the responsibility of the chemical system manufacturer and supplier to ensure that their system is safe for personnel and equipment. Some important points are described below.

- 2.1. **Ensure the System Cannot Siphon.**—The supply system must be designed to counteract any siphoning that could occur as a result of having a sealed supply line between the bottom of the chemical tank and the internal machine connection at the drain trough. As shown in the Figure 2 examples, if the pump (P) and/or the valving does not provide positive closure and there is no vacuum breaker protection, siphoning is likely to occur. In each of the Figure 2 illustrations, the volume of chemical in the tank above the siphon level (S), and indicated by shading, will flow into the machine.

Figure 2: Siphoning From the Chemical Tank into the Machine

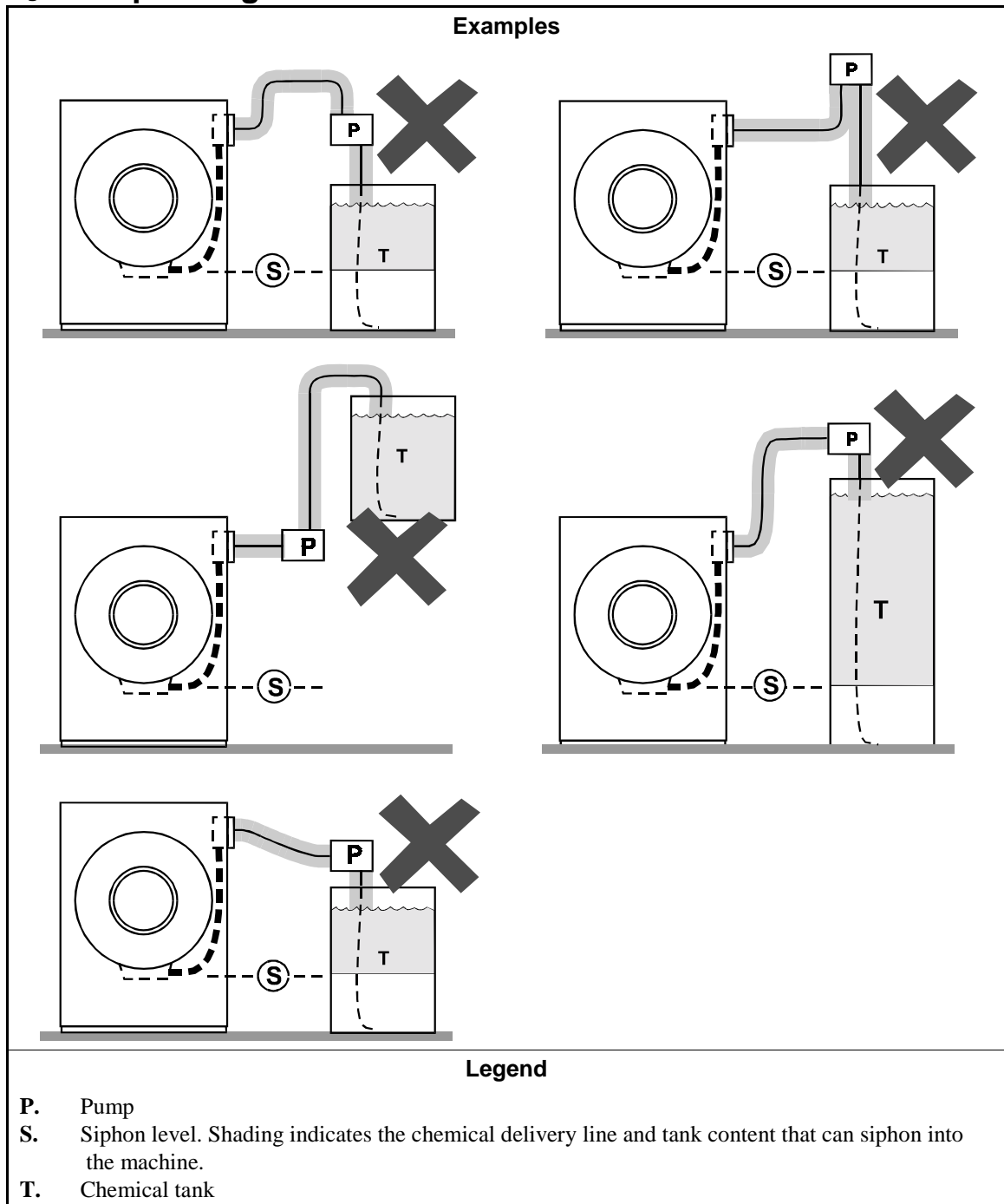

2.2. **Ensure the Chemical Lines Cannot Dribble**—The pumped chemical system may provide a means of positively closing the chemical line at the pump location, but not at the injection site. Hence, any concentrated chemical that remains in the injection line between the pump and the machine is free to flow into the machine. Some examples of this are shown in Figure 3.

Figure 3: Dribbling From Chemical Supply Line Into Machine (assumes positive closure at the pump)

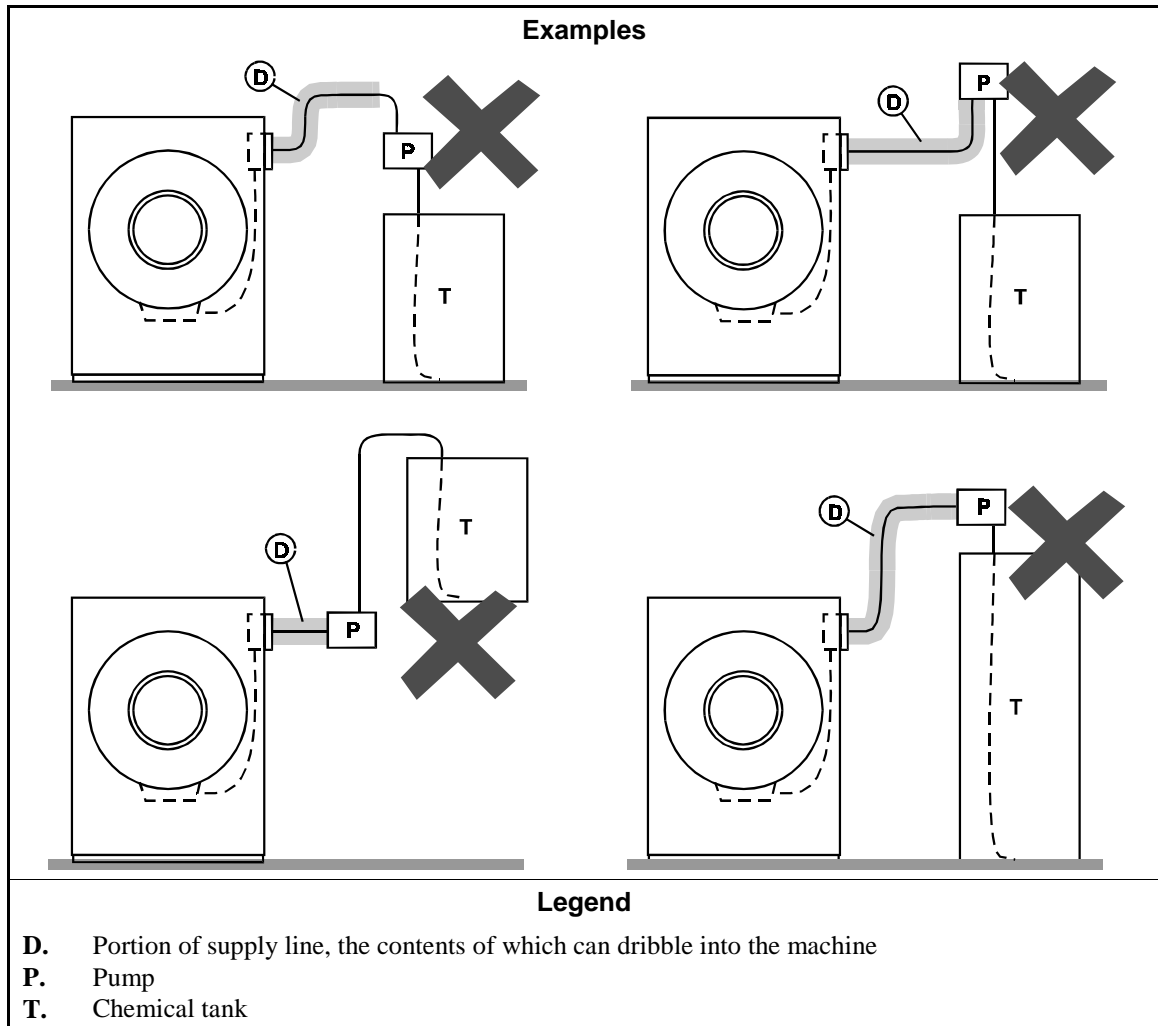

3. Design and Installation Recommendations

It is the responsibility of the chemical system manufacturer and supplier to use whatever measures are necessary to ensure that their system is safe for personnel and equipment. The following are some of the possible methods the manufacturer or supplier may wish to use, as appropriate.

- 3.1. **Siphoning: Positively close the line.**—If the pump does not provide positive closure when the system is off, employ a shutoff valve in the line to serve this purpose.
- 3.2. **Siphoning: Break the siphon.**—Provide an air gap or vacuum breaker in the chemical delivery line. This must be located above the “full” line of the tank.
- 3.3. **Dribbling: Flush the entire chemical delivery line.**—If any concentrated chemical that remains in the injection line between the pump and the machine is free to flow into the machine, employ a system that flushes the entire line between the pump and the injection point with fresh water after each injection.

- 3.4. **Dribbling: Locate the entire chemical line below the machine inlet.**— Assuming the chemical system does not retain any line pressure and that the pump provides positive closure when the system is off, locate the entire chemical delivery line below the level of the chemical inlet. An example of this is shown in Figure 4.

Figure 4: Locating a Pumped Chemical System With Positive Closure To Protect Against Machine Damage

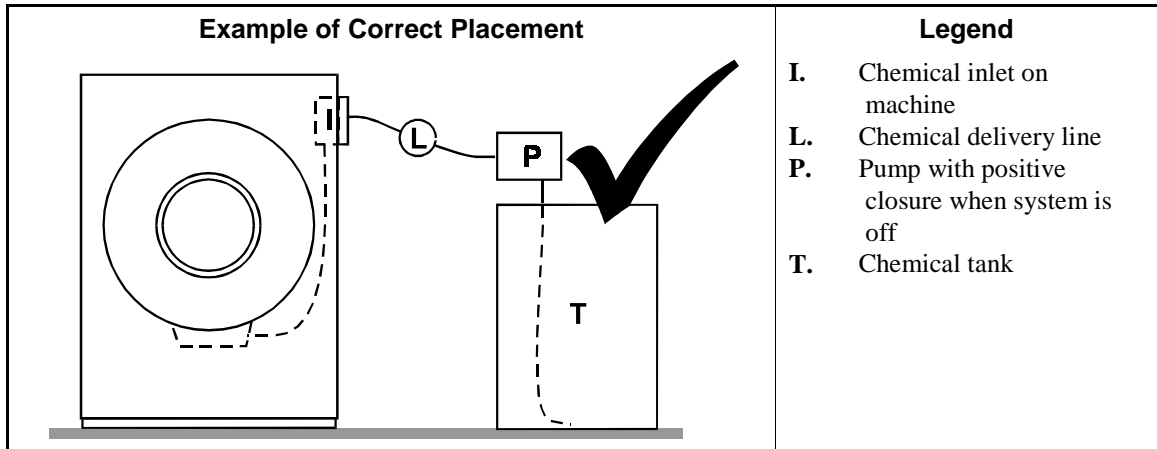

4. Guarding Against Leaks

All personnel who may work with the chemical system (e.g., chemical system manufacturer, chemical system supplier, chemical supplier, operator, maintenance personnel) should be vigilant in observing for leaks in the system. When connecting, or reconnecting chemical lines, whether at installation, after taking samples, or when replacing components, at a minimum ensure that:

1. the proper components are used,
2. all connections are the proper fit, and
3. all components are securely connected.



CAUTION [2]: Injury and Damage Hazards—Chemicals leaking from a chemical system may be corrosive or toxic. Such chemicals can injure personnel and damage equipment.

- Use care when connecting chemical lines.
- Inspect regularly for leaks.

— End of BIWUUI03 —

Section

1

Service and Maintenance

Preventive Maintenance

1. Lubrication Guidelines

As required by the warranty, to ensure safe operation, and to achieve optimum performance and service life from Milnor® washer-extractors, the schedules, instructions, and precautions herein must be strictly followed.



WARNING 1: Entangle and Crush Hazard—Belts and pulleys can entangle and crush body parts.

- Lock OFF and tag out power at the wall disconnect before servicing, except where specifically instructed otherwise in this section.
- Insure belt and pulley guards are in place during service procedures.
- Permit only qualified maintenance personnel to perform these procedures.

2. 36021C4E Main Bearing Maintenance

36021C4E main bearing housings are oil-filled and require periodic draining and refilling (see below).

See the appropriate “MAIN BEARING ASSEMBLY” (see Table of Contents) during this procedure.

1. Remove the drain plug on the bottom of the main bearing housing and allow the bearing housing to drain completely (Figure 1). Inspect the leak-off, drained oil, and magnetic drain plug for water and/or metal particles. Install the drain plug. Water and/or metal particles can indicate worn or damaged seals and bearings.
2. Locate the two 1/2" plastic tubes secured to the electrical control chassis (Figure 2). Clean the surrounding area and remove the cork stoppers from each.
3. Strictly following lubrication specifications, refill the bearing housing. After refilling the bearing housing, re-install the cork stoppers and clean any excess lubricant from the machine.

3. Preventive Maintenance Schedule

Table 1: Preventive Maintenance Checklist

Component		Action	Frequency	Specifications/Figure
Bearing Housing	Oil	Remove fill, vent and drain stoppers. Refill 22 ounces (634 grams)	Every four months	High quality SAE 30 to 50 (ISO 100 - 220) single weight heavy duty motor oil (non-detergent if available). See "Oil Drain and Water Leak-off" and also see "30022C4x,..Fill/Vent Hoses"
	Drive Train	Belts and pulleys	Check for wear, replace as required	Monthly
	Motors (if equipped with grease fittings) (See Note 2)	See "Baldor Motor Maintenance....," in this manual (See Note 3)	Every three Months	See motor nameplate. If not specified, use Shell Alvania (or equivalent). See "Motor Grease Points"
Drive Inverter	Inverter	Verify fan operation. Vacuum out inverter vents.	Monthly	See "Inverter Maintenance Points"
Hoses, Clamps, and Connections	Inlet, drain, and chemical hoses and connections	Check for leaks, cracks and bulges	Monthly	
Bolts	Foundation	Check bolt tightness and wear	Monthly	See dimensional drawings
	Rear bearing reinforcement plate and throughout machine			See "30022C4x,..Rear Reinforcement Plate" for 36021C4E and 36026V5J machines, or "42026V6J Rear Reinforcement Plate" for 42026V6J machines.

Note 1: Monthly/200 hours = Once a month or once every 200 operating hours, whichever comes first.

Note 2: Do not over-lubricate motors. Over-lubrication of a motor can seriously damage it by forcing grease into motor windings.

Note 3: If motor manufacturer's instructions conflict with manual section MSSM0274AE, follow manufacturers instructions. Motors are warranted by the manufacturers, not by Milnor.

4. Maintenance Points

Figure 1: 30022C4x, 30022T5x, 36021C4E and 36026V5J Oil Drain and Water Leak-off

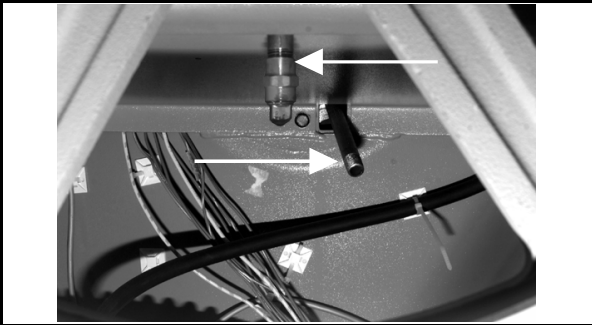

Figure 2: 30022C4x, 30022T5x, 36021C4E and 36026V5J Oil Fill/Vent Hoses (use either hose for filling)

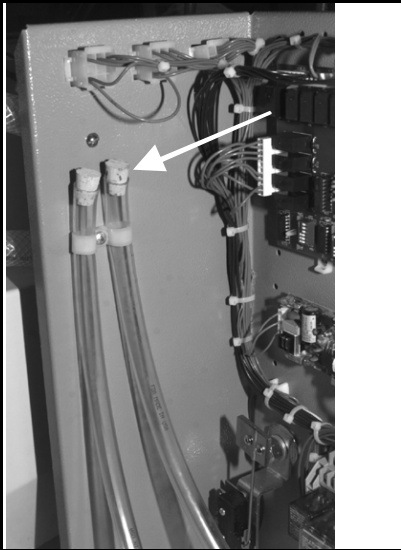

Figure 3: Drive Train Pulleys and Belts (30022V6J shown)

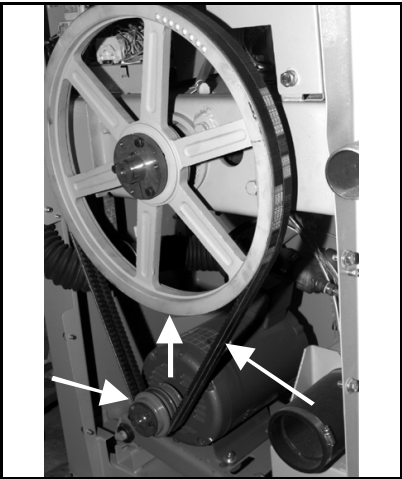

Figure 4: 30022C4x, 30022T5x, 30022V6J, 36021C4E and 36026V5J Rear Bearing Reinforcement Plate (30022VxJ shown)

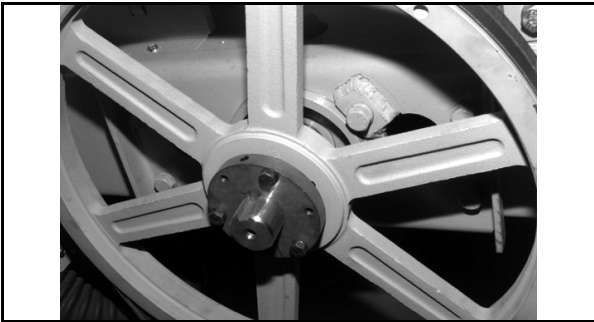
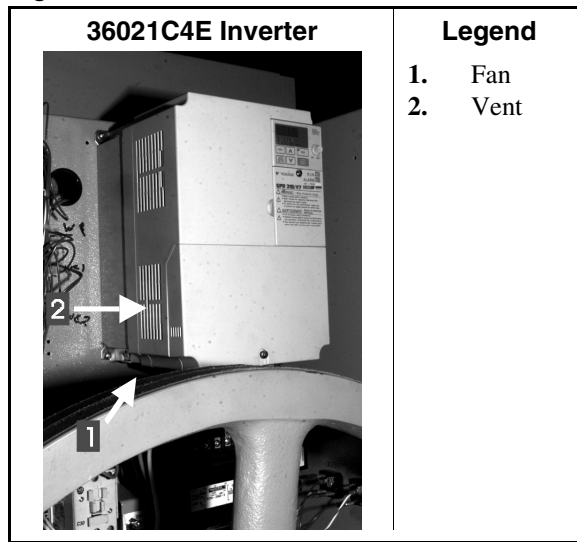

Figure 5: Inverter Maintenance Points



— End of BIRQUM01 —

FASTENER TORQUE REQUIREMENTS

The specifications in this section apply to 1/4 inch and larger Unified National fine and coarse fasteners used on Milnor[®] machines. This information is to be used only when torque specifications are not stated in the installation or service instructions.

When tightening applicable fastener, abide by the following precautions:

1. Always use new fasteners. Replace bolts, nuts, flat washers, and lock washers in the order shown on the parts drawing.
2. Unless otherwise specified, use:
 - Loctite[®] 271 threadlocker or equivalent for bearing housing mounting bolts from one half to one inch in diameter.
 - Loctite[®] 277 threadlocker or equivalent for bearing housing mounting bolts of one inch diameter or larger.
 - Loctite[®] 242 threadlocker for all other fasteners requiring thread locking compound.
3. Use a torque wrench to assure proper tightness.
4. Never lubricate fasteners. The values specified herein are maximum recommended torques and are calculated from published ASTM and SAE data. Actual allowable torques are application dependent and can vary for many reasons, (joint types, gaskets, etc.). Use these values as a guide.
5. Although FIGURE 1 depicts hex head bolts, the table applies to all head types.

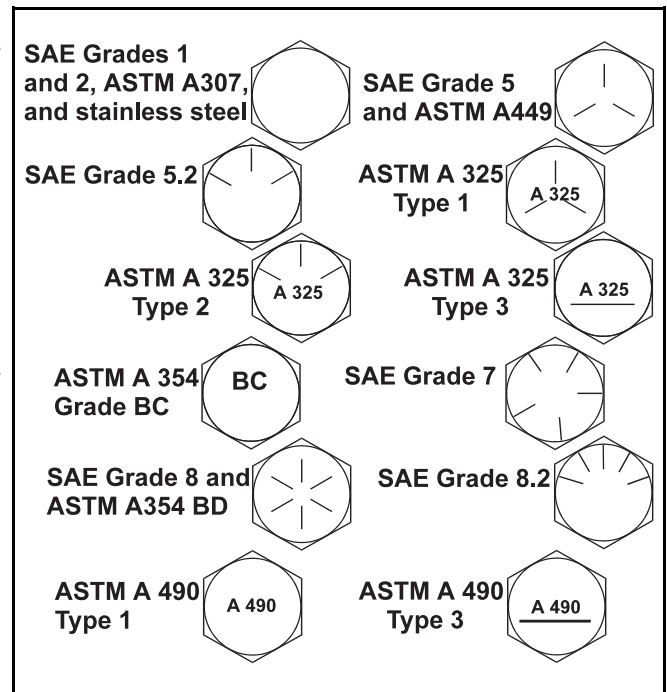

FIGURE 1 (MSSM0101CE)
Fastener Grade Markings

Fasteners and Threadlocker

How Fasteners Loosen—Standard threaded fasteners are manufactured with a clearance fit for easy assembly. With the fastener at the proper torque, 85% of the tightening torque is absorbed in the threads and under the fastener head. The remaining 15% provides the friction that prevents the thread from slipping. When this friction is overcome (by bending, thermal expansion, internal pressures, functional loads, or impact) the thread slips and loosens. Although higher torques reduce the likelihood of thread slippage, if slippage occurs, the threads unwind and the fastener loosens. Once thread slippage begins, vibration increases the rate of loosening.

Preventing Loosening—The most effective way to prevent loosening of threaded parts is by proper application of a threadlocking compound. Threadlocker provides lubrication during assembly, then hardens to seal the threads against corrosion and provide resistance to thread slippage.

Applying Threadlocker

NOTE: The following threadlocker information and illustrations are excerpts from the Loctite® User's Guide and are used with permission.

For maximum strength, threadlocker must fill the thread voids completely, as shown in FIGURE 2. Organic or petroleum solvent will remove excess uncured adhesive from joints. Consult information below for the specific fastener application.

Bolts and Nuts—See FIGURE 3.

1. Clean all threads (bolt and nut) with cleaning solvent.
2. Spray all threads with Loctite® Primer N. Allow to dry.
3. Insert bolt into through hole assembly.
4. Apply several drops of threadlocker onto bolt engagement area.
5. Assemble and tighten nut to correct torque for the threadlocker.

Blind Holes—See FIGURE 4.

1. Clean all threads (bolt and nut) with cleaning solvent.
2. Spray all threads with Loctite® Primer N. Allow to dry.
3. Squirt several drops down female threads into bottom of hole.
4. Apply several drops to bolt.
5. Tighten to correct torque for the threadlocker.

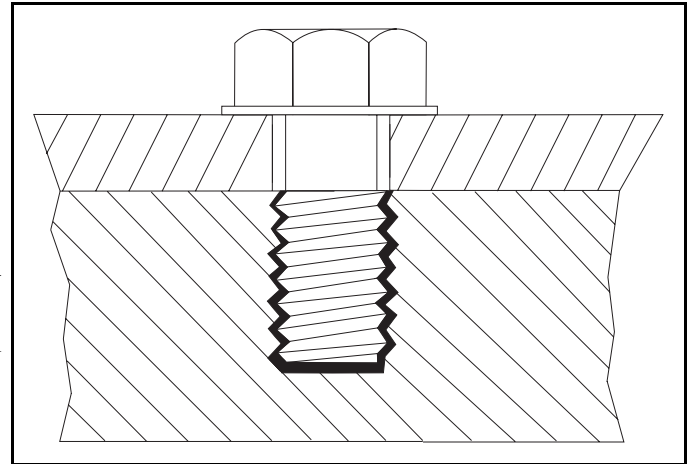

FIGURE 2 (MSSM0101CE)
Correct Threadlocker Use

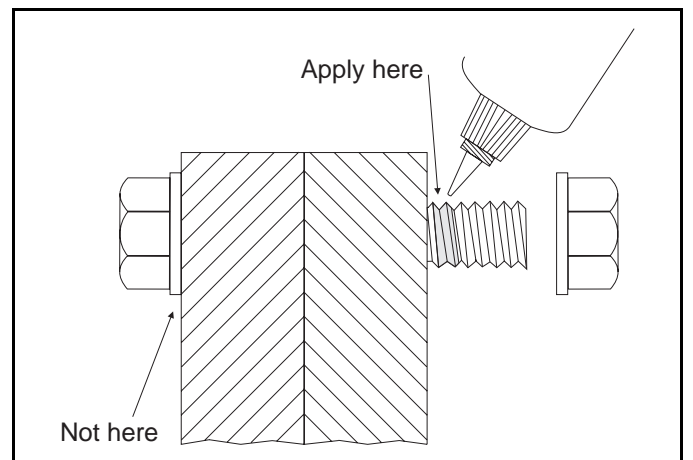

FIGURE 3 (MSSM0101CE)
Applying Threadlocker to Through Hole

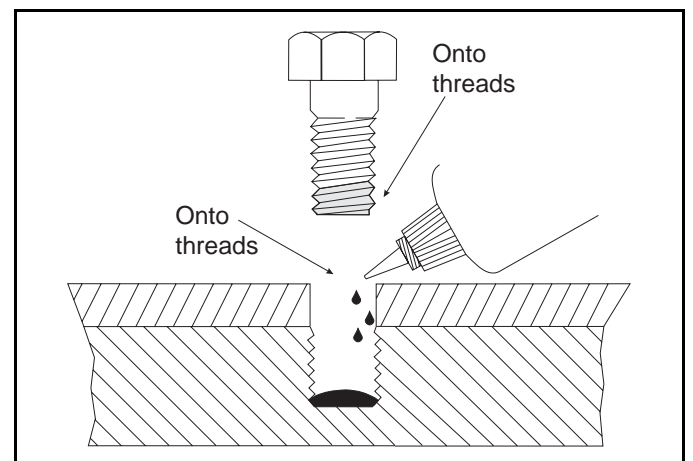

FIGURE 4 (MSSM0101CE)
Applying Threadlocker to Blind Holes

Removing Fasteners

High strength threadlockers like Loctite[®] 271 (or equivalent) may be weakened by heating to at least 500° F (260° C) as follows.

1. Apply localized heat to fastener as shown in FIGURE 5.
2. Disassemble while hot. Once disassembled, the cured adhesive can be removed with Loctite[®] Gasket Remover #790 (or equivalent).

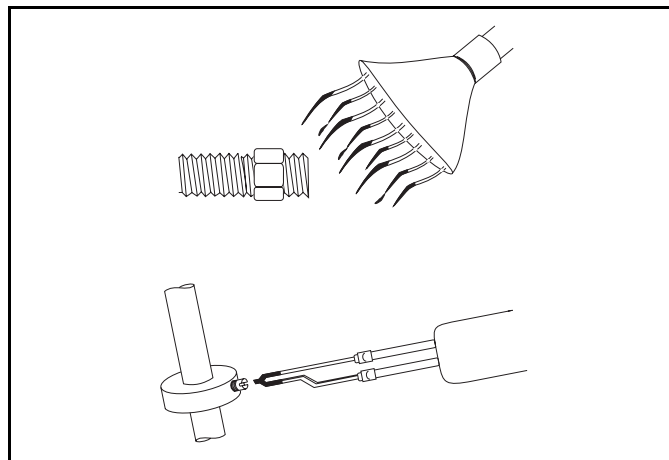

FIGURE 5 (MSSM0101CE)
Removing High Strength Threadlocker

Carbon Steel Fasteners

All values in foot pounds and (Newton meters)

Nominal bolt size	Grade Designation and Standard	Zinc or Cadmium Plated	If instructions call for :					
			Loctite 222 or 262	Loctite 242	Loctite 271	Loctite 272	Loctite 277	Bare
1/4 - 20	SAE Grade 1 ASTM A307	2.5 (3.39)	3.0 (4.06)	3.3 (4.47)	3.6 (4.88)	4.6 (6.23)	4.3 (5.83)	3.3 (4.47)
	SAE Grade 2	4.1 (5.56)	4.9 (6.64)	5.5 (7.45)	6.0 (8.13)	7.7 (10.44)	7.1 (9.63)	5.5 (7.46)
	SAE Grade 4	4.8 (6.50)	5.8 (7.86)	6.4 (8.67)	7.0 (9.49)	9.0 (12.20)	8.3 (11.25)	6.4 (8.67)
	SAE Grade 5 ASTM A449	6.3 (8.54)	7.6 (10.3)	8.4 (11.38)	9.3 (12.60)	11.8 (15.99)	11.0 (14.91)	8.4 (11.39)
	SAE Grade 7	7.9 (10.7)	9.4 (12.7)	10.5 (14.23)	11.5 (15.59)	14.7 (19.93)	13.6 (18.44)	10.5 (14.23)
	SAE Grade 8 ASTM A354 Grade BD	8.9 (12.0)	10.7 (14.5)	11.9 (16.13)	13.1 (17.76)	16.6 (22.50)	15.4 (20.88)	11.9 (16.13)
	ASTM A354 Grade BC	7.9 (10.7)	9.4 (12.7)	10.5 (14.23)	11.5 (15.59)	14.7 (19.93)	13.6 (18.44)	10.5 (14.23)

All values in foot pounds and (Newton meters)

Nominal bolt size	Grade Designation and Standard	Zinc or Cadmium Plated	If instructions call for :					
			Loctite 222 or 262	Loctite 242	Loctite 271	Loctite 272	Loctite 277	Bare
1/4 - 28	SAE Grade 1 ASTM A307	2.8 (3.80)	3.4 (4.61)	3.8 (5.15)	4.1 (5.56)	5.3 (7.18)	4.9 (6.64)	3.8 (5.15)
	SAE Grade 2	4.7 (6.37)	5.6 (7.60)	6.3 (8.54)	6.9 (9.36)	8.8 (11.93)	8.1 (10.98)	6.3 (8.54)
	SAE Grade 4	5.5 (7.46)	6.6 (8.95)	7.3 (9.90)	8.1 (10.98)	10.3 (13.96)	9.5 (12.88)	7.3 (9.90)
	SAE Grade 5 ASTM A449	7.3 (9.90)	8.7 (11.80)	9.7 (13.15)	10.7 (14.50)	13.6 (18.44)	12.6 (17.08)	9.7 (13.15)
	SAE Grade 7	8.9 (12.07)	10.7 (14.50)	11.9 (16.13)	13.1 (17.76)	16.6 (22.51)	15.4 (20.88)	11.9 (16.13)
	SAE Grade 8 ASTM A354 Grade BD	10.2 (13.83)	12.2 (16.54)	13.6 (18.44)	15.0 (20.34)	19.0 (25.76)	17.7 (23.99)	13.6 (18.44)
	ASTM A354 Grade BC	—	—	—	—	—	—	—

All values in foot pounds and (Newton meters)

Nominal bolt size	Grade Designation and Standard	Zinc or Cadmium Plated	If instructions call for :					
			Loctite 222 or 262	Loctite 242	Loctite 271	Loctite 272	Loctite 277	Bare
5/16 - 18	SAE Grade 1 ASTM A307	5.1 (6.91)	6.2 (8.40)	6.8 (9.22)	7.5 (10.17)	9.6 (13.02)	8.9 (12.07)	6.8 (9.22)
	SAE Grade 2	8.5 (11.52)	10.2 (13.83)	11.3 (15.32)	12.5 (16.95)	15.9 (21.56)	14.7 (19.93)	11.3 (15.32)
	SAE Grade 4	10.0 (13.56)	12.0 (16.27)	13.3 (18.03)	14.6 (19.79)	18.6 (25.22)	17.3 (23.46)	13.3 (18.03)
	SAE Grade 5 ASTM A449	13.0 (17.63)	15.6 (21.15)	17.4 (23.60)	19.1 (25.90)	24.3 (32.95)	22.6 (30.64)	17.4 (23.60)
	SAE Grade 7	16.1 (21.83)	19.3 (26.17)	21.5 (29.15)	23.6 (31.99)	30.1 (40.81)	27.9 (37.83)	21.5 (29.15)
	SAE Grade 8 ASTM A354 Grade BD	18.5 (25.08)	22.1 (29.96)	24.6 (33.35)	27.1 (36.74)	34.5 (46.78)	32.0 (43.39)	24.6 (33.35)
	ASTM A354 Grade BC	16.1 (21.83)	19.3 (26.17)	21.5 (29.15)	23.6 (31.99)	30.1 (40.81)	27.9 (37.83)	21.5 (29.15)

All values in foot pounds and (Newton meters)

Nominal bolt size	Grade Designation and Standard	Zinc or Cadmium Plated	If instructions call for :					
			Loctite 222 or 262	Loctite 242	Loctite 271	Loctite 272	Loctite 277	Bare
5/16 - 24	SAE Grade 1 ASTM A307	5.6 (7.59)	6.7 (9.08)	7.4 (10.03)	8.2 (11.12)	10.4 (14.10)	9.6 (13.01)	7.4 (10.03)
	SAE Grade 2	9.4 (12.74)	11.3 (15.32)	12.5 (16.94)	13.8 (18.71)	17.5 (23.73)	16.3 (22.09)	12.5 (16.94)
	SAE Grade 4	11.0 (14.91)	13.2 (17.90)	14.6 (19.79)	16.1 (21.83)	20.5 (27.79)	19.0 (25.76)	14.6 (19.79)
	SAE Grade 5 ASTM A449	14.4 (19.52)	17.2 (23.32)	19.1 (25.90)	21.1 (28.60)	26.8 (36.35)	24.9 (33.76)	19.1 (25.90)
	SAE Grade 7	17.9 (24.27)	21.4 (29.01)	23.8 (32.27)	26.2 (35.52)	33.4 (45.28)	31.0 (42.03)	23.8 (32.27)
	SAE Grade 8 ASTM A354 Grade BD	20.4 (27.66)	24.4 (33.08)	27.1 (36.74)	29.9 (40.54)	38.0 (51.52)	35.3 (47.86)	27.1 (36.74)
	ASTM A354 Grade BC	—	—	—	—	—	—	—

All values in foot pounds and (Newton meters)

Nominal bolt size	Grade Designation and Standard	Zinc or Cadmium Plated	If instructions call for :					
			Loctite 222 or 262	Loctite 242	Loctite 271	Loctite 272	Loctite 277	Bare
3/8 - 16	SAE Grade 1 ASTM A307	9.0 (12.20)	10.8 (14.64)	12.0 (16.27)	13.1 (17.76)	16.7 (22.64)	15.5 (21.01)	12.0 (16.27)
	SAE Grade 2	14.9 (20.20)	17.9 (24.27)	19.9 (26.98)	21.9 (29.69)	27.9 (37.83)	25.9 (35.11)	19.9 (26.98)
	SAE Grade 4	17.8 (24.13)	21.3 (28.88)	23.7 (32.13)	26.0 (35.25)	33.1 (44.87)	30.8 (41.76)	23.7 (32.13)
	SAE Grade 5 ASTM A449	23.2 (31.45)	27.8 (37.69)	30.9 (41.89)	34.0 (46.09)	43.3 (58.70)	40.2 (54.50)	30.9 (41.89)
	SAE Grade 7	28.7 (38.91)	34.4 (46.64)	38.2 (51.79)	42.0 (56.94)	53.5 (72.54)	49.7 (67.39)	38.2 (51.79)
	SAE Grade 8 ASTM A354 Grade BD	32.7 (44.33)	39.2 (53.15)	43.6 (59.11)	48.0 (65.08)	61.0 (82.70)	56.7 (76.87)	43.6 (59.11)
	ASTM A354 Grade BC	28.7 (38.91)	34.4 (46.64)	38.2 (51.79)	42.0 (56.94)	53.5 (72.54)	49.7 (67.39)	38.2 (51.79)

All values in foot pounds and (Newton meters)

Nominal bolt size	Grade Designation and Standard	Zinc or Cadmium Plated	If instructions call for :					
			Loctite 222 or 262	Loctite 242	Loctite 271	Loctite 272	Loctite 277	Bare
3/8 - 24	SAE Grade 1 ASTM A307	10.2 (13.83)	12.2 (16.54)	13.6 (18.44)	15.0 (20.33)	19.0 (25.76)	17.7 (24.00)	13.6 (18.44)
	SAE Grade 2	16.9 (22.91)	20.3 (27.52)	22.5 (30.52)	24.8 (33.62)	31.5 (42.70)	29.3 (39.73)	22.5 (30.50)
	SAE Grade 4	20.0 (27.11)	24.0 (32.54)	26.7 (36.20)	29.4 (39.86)	37.4 (50.70)	34.7 (47.04)	26.7 (36.20)
	SAE Grade 5 ASTM A449	26.2 (35.52)	31.4 (42.57)	34.9 (47.32)	38.4 (52.06)	48.9 (66.30)	45.4 (61.55)	34.9 (47.32)
	SAE Grade 7	32.3 (43.79)	38.8 (52.60)	43.1 (58.44)	47.4 (64.26)	60.4 (81.89)	56.1 (76.06)	43.1 (58.43)
	SAE Grade 8 ASTM A354 Grade BD	36.9 (50.02)	44.3 (60.06)	49.2 (66.70)	54.1 (73.35)	68.9 (93.41)	64.0 (86.77)	49.2 (66.70)
	ASTM A354 Grade BC	—	—	—	—	—	—	—

All values in foot pounds and (Newton meters)

Nominal bolt size	Grade Designation and Standard	Zinc or Cadmium Plated	If instructions call for :					
			Loctite 222 or 262	Loctite 242	Loctite 271	Loctite 272	Loctite 277	Bare
7/16 - 14	SAE Grade 1 ASTM A307	14.0 (18.98)	17.0 (23.04)	19.14 (25.95)	21.0 (28.47)	27.0 (36.60)	25.0 (33.89)	19.0 (25.76)
	SAE Grade 2	24.0 (32.54)	28.8 (39.05)	32.0 (43.39)	35.2 (47.72)	44.8 (60.74)	41.6 (56.40)	32.0 (43.39)
	SAE Grade 4	28.3 (38.37)	34.0 (46.10)	37.7 (51.11)	41.5 (56.27)	52.8 (71.59)	49.1 (66.57)	37.7 (51.11)
	SAE Grade 5 ASTM A449	37.1 (50.30)	44.5 (60.33)	49.5 (67.11)	54.4 (73.76)	69.3 (93.96)	64.3 (87.18)	49.5 (67.11)
	SAE Grade 7	45.9 (62.23)	55.1 (74.70)	61.3 (83.11)	67.4 (91.38)	85.8 (116.33)	79.6 (107.92)	61.3 (83.11)
	SAE Grade 8 ASTM A354 Grade BD	52.5 (71.18)	63.0 (85.41)	70.0 (94.90)	77.0 (104.40)	98.0 (132.87)	91.0 (123.38)	70.0 (94.90)
	ASTM A354 Grade BC	45.7 (61.96)	54.9 (74.43)	61.0 (82.70)	67.1 (90.97)	85.4 (115.79)	79.3 (107.52)	61.0 (82.70)

All values in foot pounds and (Newton meters)

Nominal bolt size	Grade Designation and Standard	Zinc or Cadmium Plated	If instructions call for :					
			Loctite 222 or 262	Loctite 242	Loctite 271	Loctite 272	Loctite 277	Bare
7/16 - 20	SAE Grade 1 ASTM A307	16.0 (21.70)	19.2 (26.03)	21.3 (28.88)	23.5 (31.86)	29.9 (40.54)	27.7 (37.56)	21.3 (28.88)
	SAE Grade 2	26.9 (36.48)	32.2 (43.66)	35.8 (48.54)	39.4 (53.42)	50.1 (67.93)	46.6 (63.18)	35.8 (48.54)
	SAE Grade 4	31.6 (42.84)	37.9 (51.39)	42.1 (57.08)	46.3 (62.77)	59.0 (79.99)	54.7 (74.16)	42.1 (57.08)
	SAE Grade 5 ASTM A449	41.4 (56.13)	49.7 (67.38)	55.2 (74.84)	60.8 (82.43)	77.3 (104.80)	71.8 (97.35)	55.2 (74.84)
	SAE Grade 7	51.3 (69.55)	61.5 (83.38)	68.4 (92.74)	75.2 (101.96)	95.7 (129.75)	88.9 (120.53)	68.4 (92.74)
	SAE Grade 8 ASTM A354 Grade BD	58.2 (78.90)	69.9 (94.77)	77.7 (105.35)	85.4 (115.78)	108.7 (147.37)	101.0 (136.94)	77.7 (105.35)
	ASTM A354 Grade BC	—	—	—	—	—	—	—

All values in foot pounds and (Newton meters)

Nominal bolt size	Grade Designation and Standard	Zinc or Cadmium Plated	If instructions call for :					
			Loctite 222 or 262	Loctite 242	Loctite 271	Loctite 272	Loctite 277	Bare
1/2 - 13	SAE Grade 1 ASTM A307	22.0 (29.83)	26.0 (35.25)	29.38 (39.83)	32.0 (43.39)	41.0 (55.59)	38.0 (51.52)	29.0 (39.32)
	SAE Grade 2	36.6 (49.62)	43.9 (59.52)	48.8 (66.16)	53.6 (72.67)	68.3 (92.60)	63.4 (85.96)	48.8 (66.16)
	SAE Grade 4	43.1 (58.44)	51.8 (70.23)	57.5 (77.96)	63.3 (85.82)	80.5 (109.14)	74.8 (101.42)	57.5 (77.96)
	SAE Grade 5 ASTM A449	56.7 (76.87)	68.1 (92.33)	75.6 (102.5)	83.2 (112.80)	105.9 (143.58)	98.3 (133.27)	75.6 (102.50)
	SAE Grade 7	69.8 (94.64)	83.8 (113.62)	93.1 (126.23)	102.4 (138.84)	130.4 (176.80)	121.1 (164.19)	93.1 (126.23)
	SAE Grade 8 ASTM A354 Grade BD	79.7 (108.05)	95.6 (129.62)	106.3 (144.12)	116.9 (158.50)	148.8 (201.75)	138.1 (187.24)	106.3 (144.12)
	ASTM A354 Grade BC	69.8 (94.64)	83.8 (113.62)	93.1 (126.23)	102.4 (138.84)	130.4 (176.80)	121.1 (164.19)	93.1 (126.23)

All values in foot pounds and (Newton meters)

Nominal bolt size	Standard and Grade Designation	Zinc or Cadmium Plated	If instructions call for :					
			Loctite 222 or 262	Loctite 242	Loctite 271	Loctite 272	Loctite 277	Bare
1/2 - 20	SAE Grade 1 ASTM A307	24.8 (33.62)	29.8 (40.40)	33.1 (44.88)	36.4 (49.35)	46.4 (62.91)	43.1 (58.44)	33.1 (44.88)
	SAE Grade 2	41.3 (56.00)	49.5 (67.11)	55.0 (74.57)	60.5 (82.02)	77.0 (104.40)	71.5 (96.94)	55.0 (74.57)
	SAE Grade 4	48.8 (66.16)	58.5 (79.32)	65.0 (88.13)	71.5 (96.94)	91.0 (123.38)	84.5 (114.57)	65.0 (88.13)
	SAE Grade 5 ASTM A449	63.8 (86.50)	76.5 (103.72)	85.0 (115.24)	93.5 (126.77)	119.0 (161.34)	110.5 (149.82)	85.0 (115.24)
	SAE Grade 7	78.8 (106.84)	94.5 (128.12)	105.0 (142.36)	115.5 (156.60)	147.0 (199.30)	136.5 (185.07)	105.0 (142.36)
	SAE Grade 8 ASTM A354 Grade BD	90.0 (122.02)	108.0 (146.43)	120.0 (162.70)	132.0 (179.00)	168.0 (277.78)	156.0 (211.51)	120.0 (162.70)
	ASTM A354 Grade BC	—	—	—	—	—	—	—

All values in foot pounds and (Newton meters)

Nominal bolt size	Grade Designation and Standard	Zinc or Cadmium Plated	If instructions call for :					
			Loctite 222 or 262	Loctite 242	Loctite 271	Loctite 272	Loctite 277	Bare
9/16 - 12	SAE Grade 1 ASTM A307	32.0 (43.39)	38.0 (51.52)	42.19 (57.20)	46.0 (62.37)	59.0 (80.00)	55.0 (74.57)	42 (56.94)
	SAE Grade 2	52.7 (71.45)	63.3 (85.82)	70.3 (95.31)	77.3 (104.80)	98.4 (133.41)	91.4 (123.92)	70.3 (95.31)
	SAE Grade 4	62.2 (84.33)	74.7 (101.28)	83.0 (112.53)	91.3 (123.79)	116.2 (157.55)	107.9 (146.30)	83.0 (112.53)
	SAE Grade 5 ASTM A449	81.7 (110.77)	98.1 (133.00)	109.0 (147.78)	119.9 (162.56)	152.6 (206.90)	141.7 (192.17)	109.0 (147.78)
	SAE Grade 7	100.7 (136.53)	120.9 (163.92)	134.3 (182.09)	147.7 (200.25)	188.0 (254.89)	174.6 (236.73)	134.3 (182.09)
	SAE Grade 8 ASTM A354 Grade BD	115.0 (155.92)	138.0 (187.10)	153.3 (207.85)	168.6 (228.59)	214.6 (290.96)	199.3 (270.21)	153.3 (207.85)
	ASTM A354 Grade BC	100.7 (136.53)	120.9 (163.92)	134.3 (182.09)	147.7 (200.25)	188.0 (254.89)	174.6 (236.73)	134.3 (182.09)

All values in foot pounds and (Newton meters)

Nominal bolt size	Grade Designation and Standard	Zinc or Cadmium Plated	If instructions call for:					
			Loctite 222 or 262	Loctite 242	Loctite 271	Loctite 272	Loctite 277	Bare
9/16 - 18	SAE Grade 1 ASTM A307	35.3 (47.86)	42.4 (57.49)	47.1 (63.86)	51.8 (70.23)	66.0 (89.48)	61.2 (82.98)	47.1 (63.86)
	SAE Grade 2	59.1 (80.13)	70.9 (96.13)	78.8 (106.84)	86.6 (117.41)	110.3 (149.55)	102.4 (138.84)	78.8 (106.84)
	SAE Grade 4	69.6 (94.36)	83.5 (113.21)	92.8 (125.82)	102.1 (138.43)	129.9 (176.12)	120.7 (163.65)	92.8 (125.85)
	SAE Grade 5 ASTM A449	91.2 (123.65)	109.5 (148.46)	121.6 (164.87)	133.8 (181.40)	170.3 (230.90)	158.1 (214.36)	121.6 (164.87)
	SAE Grade 7	112.3 (152.26)	134.8 (182.76)	149.8 (203.10)	164.7 (223.30)	209.7 (284.32)	194.7 (263.98)	149.8 (203.10)
	SAE Grade 8 ASTM A354 Grade BD	128.7 (174.61)	154.4 (209.34)	171.6 (232.66)	188.7 (255.84)	240.2 (325.67)	223.0 (302.35)	171.6 (232.66)
	ASTM A354 Grade BC	—	—	—	—	—	—	—

All values in foot pounds and (Newton meters)

Nominal bolt size	Grade Designation and Standard	Zinc or Cadmium Plated	If instructions call for:					
			Loctite 222 or 262	Loctite 242	Loctite 271	Loctite 272	Loctite 277	Bare
5/8 - 11	SAE Grade 1 ASTM A307	44 (59.66)	52 (70.50)	58.2 (78.90)	64 (86.77)	81 (109.82)	76 (103.04)	58 (78.64)
	SAE Grade 2	72.7 (98.57)	87.2 (118.23)	96.9 (131.38)	106.6 (144.53)	135.6 (183.85)	125.9 (170.70)	96.9 (131.38)
	SAE Grade 4	86.1 (116.74)	103.4 (140.19)	114.8 (155.65)	126.3 (171.24)	160.8 (218.02)	149.3 (202.42)	114.8 (155.65)
	SAE Grade 5 ASTM A449	112.5 (152.53)	135.0 (183.04)	150.0 (203.37)	165.0 (223.71)	210.0 (284.72)	195.0 (264.38)	150.0 (203.37)
	SAE Grade 7	138.9 (188.32)	166.6 (225.88)	185.2 (251.10)	203.7 (276.18)	259.2 (351.43)	240.7 (326.35)	185.2 (251.10)
	SAE Grade 8 ASTM A354 Grade BD	158.8 (215.30)	190.5 (258.28)	211.7 (287.03)	232.9 (315.77)	296.4 (401.86)	275.2 (373.12)	211.7 (287.03)
	ASTM A354 Grade BC	139.2 (188.73)	167.0 (226.42)	185.5 (251.50)	204.1 (276.72)	259.8 (352.24)	241.2 (327.02)	185.5 (251.50)

All values in foot pounds and (Newton meters)

Nominal bolt size	Grade Designation and Standard	Zinc or Cadmium Plated	If instructions call for:					
			Loctite 222 or 262	Loctite 242	Loctite 271	Loctite 272	Loctite 277	Bare
5/8 - 18	SAE Grade 1 ASTM A307	49.5 (67.11)	59.4 (80.54)	66.0 (89.48)	72.6 (98.43)	92.4 (125.27)	85.8 (116.33)	66.0 (89.48)
	SAE Grade 2	82.6 (112.00)	99.1 (134.36)	110.2 (149.41)	121.2 (164.33)	154.2 (209.07)	143.2 (194.15)	110.2 (149.41)
	SAE Grade 4	97.3 (131.92)	116.7 (158.22)	129.7 (175.85)	142.7 (193.48)	181.6 (246.22)	168.6 (228.59)	129.7 (175.85)
	SAE Grade 5 ASTM A449	127.7 (173.14)	153.3 (207.85)	170.3 (230.90)	187.3 (253.95)	238.4 (323.23)	221.4 (300.18)	170.3 (230.90)
	SAE Grade 7	157.6 (213.68)	189.1 (256.39)	210.2 (285.00)	231.2 (313.47)	294.2 (398.88)	273.2 (370.41)	210.2 (285.00)
	SAE Grade 8 ASTM A354 Grade BD	179.9 (243.91)	215.9 (292.72)	239.8 (325.13)	263.8 (357.66)	335.8 (455.28)	311.8 (422.74)	239.8 (325.13)
	ASTM A354 Grade BC	—	—	—	—	—	—	—

All values in foot pounds and (Newton meters)

Nominal bolt size	Grade Designation and Standard	Zinc or Cadmium Plated	If instructions call for:					
			Loctite 222 or 262	Loctite 242	Loctite 271	Loctite 272	Loctite 277	Bare
3/4 - 10	SAE Grade 1 ASTM A307	77 (104.40)	93 (126.09)	103.1 (139.78)	113 (153.20)	144 (195.24)	134 (181.68)	103 (139.65)
	SAE Grade 2	129.4 (175.44)	155.3 (210.55)	172.5 (233.88)	189.8 (257.33)	241.5 (327.43)	224.3 (304.11)	172.5 (233.88)
	SAE Grade 4	152.6 (206.90)	183.1 (248.25)	203.4 (275.77)	223.8 (303.43)	284.8 (386.14)	264.5 (358.61)	203.4 (275.77)
	SAE Grade 5 ASTM A449	199.7 (270.76)	239.6 (324.85)	266.3 (361.05)	292.9 (397.12)	372.8 (505.45)	346.1 (469.25)	266.3 (361.05)
	SAE Grade 7	246.8 (334.62)	296.2 (401.60)	329.1 (446.20)	362.0 (490.13)	460.7 (624.63)	427.8 (580.02)	329.1 (446.20)
	SAE Grade 8 ASTM A354 Grade BD	282.0 (382.34)	338.3 (458.67)	375.9 (509.65)	413.5 (560.63)	526.3 (713.57)	488.7 (662.59)	375.9 (509.65)
	ASTM A354 Grade BC	246.4 (334.07)	295.7 (400.92)	328.6 (445.53)	361.5 (490.13)	460.0 (623.67)	427.2 (579.20)	328.6 (445.53)

All values in foot pounds and (Newton meters)

Nominal bolt size	Grade Designation and Standard	Zinc or Cadmium Plated	If instructions call for:					
			Loctite 222 or 262	Loctite 242	Loctite 271	Loctite 272	Loctite 277	Bare
3/4 - 16	SAE Grade 1 ASTM A307	86.5 (117.28)	103.8 (140.73)	115.3 (156.33)	126.8 (171.92)	161.4 (218.83)	149.9 (203.24)	115.3 (156.33)
	SAE Grade 2	144.1 (195.37)	173.0 (234.56)	192.2 (260.59)	211.4 (286.62)	269.1 (364.85)	249.8 (338.68)	192.2 (260.59)
	SAE Grade 4	170.2 (230.76)	204.2 (276.86)	226.9 (307.64)	249.6 (338.41)	317.6 (430.61)	294.9 (399.15)	226.9 (307.64)
	SAE Grade 5 ASTM A449	222.9 (302.21)	267.5 (362.68)	297.2 (402.95)	326.9 (443.22)	416.1 (564.16)	386.3 (523.75)	297.2 (402.95)
	SAE Grade 7	275.6 (373.66)	330.8 (448.50)	367.5 (498.26)	404.3 (548.16)	514.5 (697.57)	477.8 (647.81)	367.5 (498.26)
	SAE Grade 8 ASTM A354 Grade BD	315.0 (427.08)	378.0 (512.50)	420.0 (569.44)	462.0 (626.39)	588.0 (797.22)	546.0 (740.28)	420.0 (569.44)
	ASTM A354 Grade BC	—	—	—	—	—	—	—

All values in foot pounds and (Newton meters)

Nominal bolt size	Grade Designation and Standard	Zinc or Cadmium Plated	If instructions call for:					
			Loctite 222 or 262	Loctite 242	Loctite 271	Loctite 272	Loctite 277	Bare
7/8 - 9	SAE Grade 1 ASTM A307	124.7 (169.07)	149.6 (202.83)	166.3 (225.47)	182.9 (247.98)	232.8 (315.63)	216.1 (293.0)	166.3 (225.47)
	SAE Grade 2	124.7 (169.07)	149.6 (202.83)	166.3 (225.47)	182.9 (247.98)	232.8 (315.63)	216.1 (293.00)	166.3 (225.47)
	SAE Grade 4	246.1 (333.67)	295.3 (400.37)	328.1 (444.84)	360.9 (489.32)	459.4 (622.86)	426.6 (578.40)	328.1 (444.84)
	SAE Grade 5 ASTM A449	322.4 (437.11)	386.9 (524.57)	429.8 (582.73)	472.8 (641.03)	601.8 (815.93)	558.8 (757.63)	429.8 (582.73)
	SAE Grade 7	397.9 (539.48)	477.4 (647.27)	530.5 (719.26)	583.5 (791.12)	742.7 (1007.00)	689.6 (935.00)	530.5 (719.26)
	SAE Grade 8 ASTM A354 Grade BD	454.5 (616.22)	545.3 (739.33)	605.9 (821.49)	666.5 (903.65)	848.3 (1150.14)	787.7 (1067.98)	605.9 (821.49)
	ASTM A354 Grade BC	397.9 (539.48)	477.4 (647.27)	530.5 (719.26)	583.5 (791.12)	742.7 (1007.00)	689.6 (935.00)	530.5 (719.26)

All values in foot pounds and (Newton meters)

Nominal bolt size	Grade Designation and Standard	Zinc or Cadmium Plated	If instructions call for:					
			Loctite 222 or 262	Loctite 242	Loctite 271	Loctite 272	Loctite 277	Bare
7/8 - 14	SAE Grade 1 ASTM A307	137.8 (186.83)	165.4 (224.25)	183.8 (249.20)	202.1 (274.01)	257.3 (348.85)	238.9 (323.90)	183.8 (249.20)
	SAE Grade 2	137.8 (186.83)	165.4 (224.25)	183.8 (249.20)	202.1 (274.01)	257.3 (348.85)	238.9 (323.90)	183.8 (249.20)
	SAE Grade 4	271.5 (368.11)	325.8 (441.73)	362.0 (490.80)	398.2 (539.89)	506.8 (687.13)	470.6 (638.05)	362.0 (490.80)
	SAE Grade 5 ASTM A449	355.2 (481.59)	426.2 (577.85)	473.6 (642.12)	521.0 (706.38)	663.0 (898.91)	615.7 (834.78)	473.6 (642.12)
	SAE Grade 7	438.0 (593.85)	525.7 (712.75)	584.1 (791.93)	642.5 (871.11)	817.7 (1108.65)	759.3 (1029.47)	584.1 (791.93)
	SAE Grade 8 ASTM A354 Grade BD	501.2 (679.54)	601.5 (815.53)	668.3 (906.09)	735.1 (996.66)	935.6 (1268.50)	868.8 (1177.94)	668.3 (906.09)
	ASTM A354 Grade BC	—	—	—	—	—	—	—

All values in foot pounds and (Newton meters)

Nominal bolt size	Grade Designation and Standard	Zinc or Cadmium Plated	If instructions call for:					
			Loctite 222 or 262	Loctite 242	Loctite 271	Loctite 272	Loctite 277	Bare
1 - 8	SAE Grade 1 ASTM A307	187.5 (254.22)	225.0 (305.06)	250.0 (338.95)	275.0 (372.85)	350.0 (474.54)	325.0 (440.64)	250.0 (338.95)
	SAE Grade 2	187.5 (254.22)	225.0 (305.06)	250.0 (338.95)	275.0 (372.85)	350.0 (474.54)	325.0 (440.64)	250.0 (338.95)
	SAE Grade 4	369.4 (500.84)	443.3 (601.03)	492.5 (667.74)	541.8 (734.58)	689.5 (934.84)	640.3 (868.13)	492.5 (667.74)
	SAE Grade 5 ASTM A449	482.8 (654.59)	579.4 (785.56)	643.8 (872.88)	708.1 (960.05)	901.3 (1222.00)	836.9 (1134.69)	643.8 (872.88)
	SAE Grade 7	596.3 (808.47)	715.5 (970.09)	795.0 (1077.88)	874.5 (1185.66)	1113.0 (1509.03)	1033.5 (1401.24)	795.0 (1077.88)
	SAE Grade 8 ASTM A354 Grade BD	681.6 (924.13)	817.9 (1108.92)	908.8 (1232.17)	999.6 (1355.28)	1272.3 (1725.00)	1181.4 (1601.77)	908.8 (1232.17)
	ASTM A354 Grade BC	596.7 (809.01)	716.1 (970.90)	795.6 (1078.69)	875.2 (1186.61)	1113.9 (1510.25)	1034.3 (1402.32)	795.6 (1078.69)

All values in foot pounds and (Newton meters)

Nominal bolt size	Grade Designation and Standard	Zinc or Cadmium Plated	If instructions call for :					
			Loctite 222 or 262	Loctite 242	Loctite 271	Loctite 272	Loctite 277	Bare
1 - 12	SAE Grade 1 ASTM A307	205.3 278.35	246.4 (334.07)	273.8 (371.22)	301.1 (408.24)	383.3 (519.69)	355.9 (482.54)	273.8 (371.22)
	SAE Grade 2	205.3 (278.35)	246.4 (334.07)	273.8 (371.22)	301.1 (408.24)	383.3 (519.69)	355.9 (482.54)	273.8 (371.22)
	SAE Grade 4	404.1 (547.88)	484.9 (657.44)	538.8 (730.52)	592.6 (803.46)	754.3 (1022.70)	700.4 (949.62)	538.8 (730.52)
	SAE Grade 5 ASTM A449	528.8 (716.96)	634.5 (860.27)	705.0 (955.85)	775.5 (1051.44)	987.0 (1338.19)	916.5 (1242.61)	705.0 (955.85)
	SAE Grade 7	652.5 (884.67)	783.0 (1061.60)	870.0 (1179.56)	957.0 (1297.52)	1218.0 (1651.39)	1131.0 (1533.42)	870.0 (1179.56)
	SAE Grade 8 ASTM A354 Grade BD	746.3 (1011.85)	895.5 (1214.14)	995.0 (1349.04)	1094.5 (1483.49)	1393.0 (1888.66)	1293.5 (1753.73)	995.0 (1349.04)
	ASTM A354 Grade BC	—	—	—	—	—	—	—

All values in foot pounds and (Newton meters)

Nominal bolt size	Grade Designation and Standard	Zinc or Cadmium Plated	If instructions call for :					
			Loctite 222 or 262	Loctite 242	Loctite 271	Loctite 272	Loctite 277	Bare
1 - 14	SAE Grade 1 ASTM A307	210.0 (284.72)	252.0 (341.66)	280.0 (379.63)	308.0 (417.60)	392.0 (531.48)	364.0 (493.52)	280.0 (379.63)
	SAE Grade 2	210.0 (284.72)	252.0 (341.66)	280.0 (379.63)	308.0 (417.60)	392.0 (531.48)	364.0 (493.52)	280.0 (379.63)
	SAE Grade 4	413.4 (560.50)	496.1 (672.62)	551.3 (747.46)	606.4 (822.17)	771.8 (1046.42)	716.6 (971.58)	551.3 (747.46)
	SAE Grade 5 ASTM A449	540.9 (733.36)	649.1 (880.06)	721.3 (977.95)	793.4 (1075.70)	1009.8 (1369.10)	937.6 (1271.22)	721.3 (977.95)
	SAE Grade 7	668.4 (906.23)	802.1 (1087.50)	891.3 (1208.44)	980.4 (1329.25)	1247.8 (1691.79)	1158.6 (1570.85)	891.3 (1208.44)
	SAE Grade 8 ASTM A354 Grade BD	764.1 (1035.98)	916.9 (1243.15)	1018.8 (1381.31)	1120.6 (1519.33)	1426.3 (1933.80)	1324.4 (1795.65)	1018.8 (1381.30)
	ASTM A354 Grade BC	—	—	—	—	—	—	—

All values in foot pounds and (Newton meters)

Nominal bolt size	Grade Designation and Standard	Zinc or Cadmium Plated	If instructions call for :					
			Loctite 222 or 262	Loctite 242	Loctite 271	Loctite 272	Loctite 277	Bare
1-1/8 • 7	SAE Grade 1 ASTM A307	265.8 (360.37)	318.9 (432.37)	354.4 (480.50)	389.8 (528.50)	496.1 (672.62)	460.7 (624.63)	354.4 (480.50)
	SAE Grade 2	265.8 (360.37)	318.9 (432.37)	354.4 (480.50)	389.8 (528.50)	496.1 (672.62)	460.7 (624.63)	354.4 (480.50)
	SAE Grade 4	523.1 (709.23)	627.8 (851.18)	697.5 (945.68)	767.3 (1040.32)	976.5 (1323.96)	906.8 (1229.46)	697.5 (945.68)
	SAE Grade 5 ASTM A449	595.9 (807.93)	715.1 (969.55)	794.5 (1077.20)	874.0 (1184.99)	1112.3 (1508.07)	1032.9 (1400.43)	794.5 (1077.20)
	SAE Grade 7	844.8 (1145.40)	1013.8 (1374.53)	1126.4 (1527.20)	1239.0 (1679.86)	1577.0 (2138.13)	1464.3 (1985.33)	1126.4 (1527.20)
	SAE Grade 8 ASTM A354 Grade BD	966.1 (1309.86)	1159.3 (1571.80)	1288.1 (1746.43)	1416.9 (1921.06)	1803.4 (2445.08)	1674.6 (2270.46)	1288.1 (1746.43)
	ASTM A354 Grade BC	844.8 (1145.40)	1013.8 (1374.53)	1126.4 (1527.20)	1239.0 (1679.86)	1577.0 (2138.13)	1464.3 (1985.33)	1126.4 (1527.20)

All values in foot pounds and (Newton meters)

Nominal bolt size	Grade Designation and Standard	Zinc or Cadmium Plated	If instructions call for :					
			Loctite 222 or 262	Loctite 242	Loctite 271	Loctite 272	Loctite 277	Bare
1-1/8 • 12	SAE Grade 1 ASTM A307	297.4 (403.22)	356.9 (483.89)	396.6 (537.72)	436.2 (591.40)	555.2 (752.75)	515.5 (698.93)	396.6 (537.72)
	SAE Grade 2	297.4 (403.22)	356.9 (483.89)	396.6 (537.72)	436.2 (591.40)	555.2 (752.75)	515.5 (698.93)	396.6 (537.72)
	SAE Grade 4	586.4 (795.05)	703.7 (954.09)	781.9 (1060.12)	860.1 (1166.14)	1094.6 (1484.08)	1016.4 (1378.06)	781.9 (1060.12)
	SAE Grade 5 ASTM A449	667.6 (905.14)	801.1 (1086.15)	890.2 (1206.95)	979.2 (1327.62)	1246.2 (1689.62)	1157.2 (1568.95)	890.2 (1206.95)
	SAE Grade 7	948.2 (1285.58)	1137.8 (1542.65)	1264.2 (1714.02)	1390.6 (1855.40)	1769.9 (2399.66)	1643.5 (2228.30)	1264.2 (1714.02)
	SAE Grade 8 ASTM A354 Grade BD	1083.2 (1468.62)	1299.8 (1762.30)	1444.2 (1958.07)	1588.6 (2153.85)	2021.9 (2741.33)	1877.5 (2545.55)	1444.2 (1958.07)
	ASTM A354 Grade BC	—	—	—	—	—	—	—

All values in foot pounds and (Newton meters)

Nominal bolt size	Grade Designation and Standard	Zinc or Cadmium Plated	If instructions call for :					
			Loctite 222 or 262	Loctite 242	Loctite 271	Loctite 272	Loctite 277	Bare
1-1/4 • 7	SAE Grade 1 ASTM A307	375.0 (508.43)	450.0 (610.11)	500.0 (677.91)	550.0 (745.70)	700.0 (949.07)	650.0 (881.28)	500.0 (677.91)
	SAE Grade 2	375.0 (508.43)	450.0 (610.11)	500.0 (677.91)	550.0 (745.70)	700.0 (949.07)	650.0 (881.28)	500.0 (677.91)
	SAE Grade 4	738.3 (1001.00)	885.9 (1201.12)	984.4 (1334.67)	1082.8 (1468.08)	1378.1 (1868.45)	1279.7 (1735.04)	984.4 (1334.67)
	SAE Grade 5 ASTM A449	840.2 (1139.16)	1008.3 (1367.07)	1120.3 (1518.93)	1232.3 (1670.78)	1568.4 (2126.47)	1456.4 (1974.62)	1120.3 (1518.93)
	SAE Grade 7	1191.8 (1615.87)	1430.2 (1939.09)	1589.1 (2154.53)	1748.0 (2369.97)	2224.7 (3016.30)	2065.8 (2800.85)	1589.1 (2154.53)
	SAE Grade 8 ASTM A354 Grade BD	1362.9 (1847.85)	1635.5 (2217.44)	1817.2 (2463.80)	1998.9 (2710.15)	2544.1 (3449.34)	2362.3 (3202.85)	1817.2 (2463.80)
	ASTM A354 Grade BC	1192.4 (1616.68)	1430.9 (1940.04)	1589.8 (2155.48)	1748.8 (2371.05)	2225.8 (3017.78)	2066.8 (2802.20)	1589.8 (2155.48)

All values in foot pounds and (Newton meters)

Nominal bolt size	Grade Designation and Standard	Zinc or Cadmium Plated	If instructions call for :					
			Loctite 222 or 262	Loctite 242	Loctite 271	Loctite 272	Loctite 277	Bare
1-1/4 • 12	SAE Grade 1 ASTM A307	414.8 (562.40)	497.8 (674.93)	553.1 (749.90)	608.4 (824.88)	774.4 (1049.95)	719.1 (974.97)	553.1 (749.90)
	SAE Grade 2	414.8 (562.40)	497.8 (674.93)	553.1 (749.90)	608.4 (824.88)	774.4 (1049.95)	719.1 (974.97)	553.1 (749.90)
	SAE Grade 4	816.8 (1107.43)	980.2 (1328.97)	1089.1 (1476.62)	1198.0 (1624.27)	1524.7 (2067.22)	1415.8 (1919.57)	1089.1 (1476.62)
	SAE Grade 5 ASTM A449	930.5 (1261.60)	1116.6 (1513.90)	1240.6 (1682.03)	1364.7 (1850.29)	1736.9 (2354.92)	1612.8 (2186.66)	1240.6 (1682.03)
	SAE Grade 7	1320.7 (1790.63)	1584.8 (2148.70)	1760.9 (2387.46)	1937.0 (2626.22)	2465.3 (3342.50)	2289.2 (3103.74)	1760.9 (2387.46)
	SAE Grade 8 ASTM A354 Grade BD	1509.4 (2046.47)	1811.3 (2455.80)	2012.5 (2728.59)	2213.8 (3001.51)	2817.5 (3820.02)	2616.3 (3547.23)	2012.5 (2728.58)
	ASTM A354 Grade BC	—	—	—	—	—	—	—

All values in foot pounds and (Newton meters)

Nominal bolt size	Grade Designation and Standard	Zinc or Cadmium Plated	If instructions call for :					
			Loctite 222 or 262	Loctite 242	Loctite 271	Loctite 272	Loctite 277	Bare
1-3/8 • 6	SAE Grade 1 ASTM A307	491.1 (665.84)	589.4 (799.12)	654.8 (887.79)	720.3 (976.60)	916.8 (1243.00)	851.3 (1154.21)	654.8 (887.80)
	SAE Grade 2	491.1 (665.84)	589.4 (799.12)	654.8 (887.79)	720.3 (976.60)	916.8 (1243.00)	851.3 (1154.21)	654.8 (887.80)
	SAE Grade 4	968.1 (1312.57)	1161.7 (1575.06)	1290.8 (1750.10)	1419.9 (1925.13)	1807.1 (2450.10)	1678.0 (2275.07)	1290.8 (1750.09)
	SAE Grade 5 ASTM A449	1102.1 (1494.25)	1322.6 (1793.20)	1469.5 (1992.38)	1616.5 (2191.68)	2057.3 (2789.33)	1910.4 (2590.16)	1469.5 (1992.38)
	SAE Grade 7	1563.6 (2119.96)	1876.4 (2544.06)	2084.8 (2826.61)	2293.3 (3109.30)	2918.8 (3957.37)	2710.3 (3674.68)	2084.8 (2826.61)
	SAE Grade 8 ASTM A354 Grade BD	1786.6 (2422.30)	2144.0 (2906.88)	2382.2 (3229.83)	2620.4 (3552.79)	3335.1 (4521.80)	3096.8 (4198.70)	2382.2 (3229.83)
	ASTM A354 Grade BC	1563.6 (2119.96)	1876.4 (2544.06)	2084.8 (2826.61)	2293.3 (3109.30)	2918.8 (3957.37)	2710.3 (3674.68)	2084.8 (2826.61)

All values in foot pounds and (Newton meters)

Nominal bolt size	Grade Designation and Standard	Zinc or Cadmium Plated	If instructions call for :					
			Loctite 222 or 262	Loctite 242	Loctite 271	Loctite 272	Loctite 277	Bare
1-3/8 • 12	SAE Grade 1 ASTM A307	559.5 (758.58)	671.3 (910.16)	745.9 (1011.30)	820.5 (1112.45)	1044.3 (1415.88)	969.7 (1314.74)	745.9 (1011.30)
	SAE Grade 2	559.5 (758.58)	671.3 (910.16)	745.9 (1011.30)	820.5 (1112.45)	1044.3 (1415.88)	969.7 (1314.74)	745.9 (1011.30)
	SAE Grade 4	1102.1 (1494.25)	1322.6 (1793.21)	1469.5 (1992.38)	1616.5 (2191.68)	2057.3 (2789.33)	1910.4 (2590.16)	1469.5 (1992.38)
	SAE Grade 5 ASTM A449	1254.3 (1700.60)	1505.1 (2040.64)	1672.3 (2267.34)	1839.6 (2494.16)	2341.3 (3174.38)	2174.0 (2947.55)	1672.3 (2267.34)
	SAE Grade 7	1780.2 (2413.63)	2136.2 (2896.30)	2373.6 (3218.17)	2611.0 (3540.04)	3323.0 (4505.39)	3085.7 (4183.65)	2373.6 (3218.17)
	SAE Grade 8 ASTM A354 Grade BD	2034.1 (2757.87)	2441.0 (3309.56)	2712.2 (3677.25)	2983.4 (4044.95)	3797.1 (5148.18)	3525.8 (4780.35)	2712.2 (3677.25)
	ASTM A354 Grade BC	—	—	—	—	—	—	—

All values in foot pounds and (Newton meters)

Nominal bolt size	Grade Designation and Standard	Zinc or Cadmium Plated	If instructions call for :					
			Loctite 222 or 262	Loctite 242	Loctite 271	Loctite 272	Loctite 277	Bare
1-1/2 • 6	SAE Grade 1 ASTM A307	652.5 (884.67)	783.0 (1061.60)	870.0 (1179.56)	957.0 (1297.52)	1218.0 (1651.39)	1131.0 (1533.43)	870.0 (1179.56)
	SAE Grade 2	652.5 (884.67)	783.0 (1061.60)	870.0 (1179.56)	957.0 (1297.52)	1218.0 (1651.39)	1131.0 (1533.43)	870.0 (1179.56)
	SAE Grade 4	1283.9 (1740.74)	1540.7 (2088.91)	1711.9 (2321.03)	1883.1 (2553.14)	2396.6 (3249.36)	2225.4 (3017.24)	1711.9 (2321.03)
	SAE Grade 5 ASTM A449	1462.5 (1982.88)	1755.0 (2379.46)	1950.0 (2643.85)	2145.0 (2908.23)	2730.0 (3701.39)	2535.0 (3437.00)	1950.0 (2643.85)
	SAE Grade 7	2074.2 (2812.24)	2489.1 (3374.77)	2765.6 (3749.66)	3042.2 (4124.67)	3871.9 (5249.60)	3595.3 (4874.58)	2765.6 (3749.66)
	SAE Grade 8 ASTM A354 Grade BD	2370.9 (3214.51)	2845.1 (3857.44)	3161.3 (4286.15)	3477.4 (4714.73)	4425.8 (6000.58)	4109.6 (5571.88)	3161.3 (4286.15)
	ASTM A354 Grade BC	2074.9 (2813.20)	2489.9 (3375.85)	2766.6 (3751.01)	3043.2 (4126.03)	3873.2 (5251.36)	3596.5 (4876.20)	2766.6 (3751.01)

All values in foot pounds and (Newton meters)

Nominal bolt size	Grade Designation and Standard	Zinc or Cadmium Plated	If instructions call for :					
			Loctite 222 or 262	Loctite 242	Loctite 271	Loctite 272	Loctite 277	Bare
1-1/2 • 12	SAE Grade 1 ASTM A307	734.1 (995.30)	880.9 (1194.34)	978.8 (1327.07)	1076.6 (1459.67)	1370.3 (1857.88)	1272.4 (1725.14)	978.8 (1327.07)
	SAE Grade 2	734.1 (995.30)	880.9 (1194.34)	978.8 (1327.07)	1076.6 (1459.67)	1370.3 (1857.88)	1272.4 (1725.14)	978.8 (1327.07)
	SAE Grade 4	1445.6 (1959.97)	1734.8 (2352.07)	1927.5 (2613.34)	2120.3 (2874.33)	2698.5 (3658.68)	2505.8 (3397.41)	1927.5 (2613.34)
	SAE Grade 5 ASTM A449	1645.3 (2230.73)	1974.4 (2676.93)	2193.8 (2974.40)	2413.1 (3271.73)	3071.3 (4164.13)	2851.9 (3866.66)	2193.8 (2974.40)
	SAE Grade 7	2334.4 (3165.02)	2801.3 (3798.06)	3112.5 (4219.99)	3423.8 (4642.05)	4357.5 (5907.98)	4046.3 (5486.05)	3112.5 (4219.99)
	SAE Grade 8 ASTM A354 Grade BD	2667.7 (3616.92)	3201.2 (4340.25)	3556.9 (4822.51)	3912.6 (5304.78)	4979.6 (6751.44)	4623.9 (6269.17)	3556.9 (4822.51)
	ASTM A354 Grade BC	—	—	—	—	—	—	—

Other Fastener Torque Specifications

All values in foot-pounds and (Newton-meters)

Nominal bolt size	18 - 8 Stainless Steel	316 Stainless Steel	Brass	Aluminum 2024 - T4
1/4 - 20	6.3 (8.54)	6.6 (8.95)	5.1 (6.91)	3.8 (5.15)
1/4 - 28	7.8 (10.57)	8.3 (11.25)	6.4 (8.67)	4.8 (6.50)
5/16 - 18	11.0 (14.90)	11.5 (15.60)	8.9 (12.06)	6.7 (9.08)
5/16 - 24	11.8 (16.00)	12.3 (16.67)	9.7 (13.15)	7.2 (9.76)
3/8 - 16	19.7 (26.71)	20.6 (27.93)	16.0 (21.70)	11.9 (16.13)
3/8 - 24	21.6 (29.28)	22.6 (30.64)	17.7 (24.00)	13.1 (17.76)
7/16 - 14	31.3 (42.44)	32.8 (44.47)	26.4 (35.80)	19.0 (25.76)
7/16 - 20	33.3 (45.15)	34.8 (47.18)	27.3 (37.00)	20.2 (27.38)
1/2 - 13	43.1 (58.43)	45.2 (61.28)	35.2 (47.72)	26.1 (35.38)
1/2 - 20	45.1 (61.14)	47.1 (63.86)	36.9 (50.00)	27.3 (37.00)
9/16 - 12	56.8 (77.00)	59.4 (80.53)	46.5 (63.04)	34.4 (46.64)
9/16 - 18	62.7 (85.00)	65.6 (88.94)	51.3 (69.55)	38.0 (51.52)
5/8 - 11	92.5 (125.41)	96.7 (131.10)	75.6 (102.50)	59.6 (80.80)
5/8 - 18	103.7 (140.60)	108.4 (146.97)	84.7 (114.84)	66.5 (90.16)
3/4 - 10	127.5 (172.86)	131.8 (178.70)	104.1 (141.14)	81.7 (110.77)
3/4 - 16	124.2 (168.39)	129.8 (175.98)	101.7 (137.88)	79.8 (108.19)

Other Fastener Torque Specifications

All values in foot-pounds and (Newton-meters)

Nominal bolt size	18 - 8 Stainless Steel	316 Stainless Steel	Brass	Aluminum 2024 - T4
7/8 - 9	194.0 (263.03)	202.5 (274.55)	158.8 (215.30)	124.6 (168.93)
7/8 - 14	193.2 (261.94)	201.7 (273.47)	157.9 (214.08)	124.2 (168.40)
1 - 8	286.7 (388.71)	299.6 (406.20)	234.6 (318.07)	183.8 (249.20)
1 - 14	259.2 (351.43)	270.8 (367.16)	212.1 (287.57)	166.3 (225.47)
1-1/8 • 7	413.0 (559.95)	432.0 (585.71)	337.0 (456.91)	265.0 (359.29)
1-1/8 • 12	390.0 (528.77)	408.0 (553.17)	318.0 (431.15)	251.0 (340.31)
1-1/4 • 7	523.0 (709.09)	546.0 (740.28)	428.0 (580.30)	336.0 (455.55)
1-1/4 • 12	480.0 (650.80)	504.0 (683.33)	394.0 (534.19)	308.0 (417.60)
1-1/2 • 6	888.0 (1203.97)	930.0 (1260.91)	727.0 (985.68)	570.0 (772.82)
1-1/2 • 12	703.0 (953.14)	732.0 (992.46)	575.0 (779.60)	450.0 (610.12)

Section
Drive Assemblies

2

Drive Chart

30015 & 30022C4E

BMP020055/2002446V
(Sheet 1 of 1)



Pellerin Milnor Corporation
P. O. Box 400, Kenner, LA 70063-0400

Litho in U.S.A.

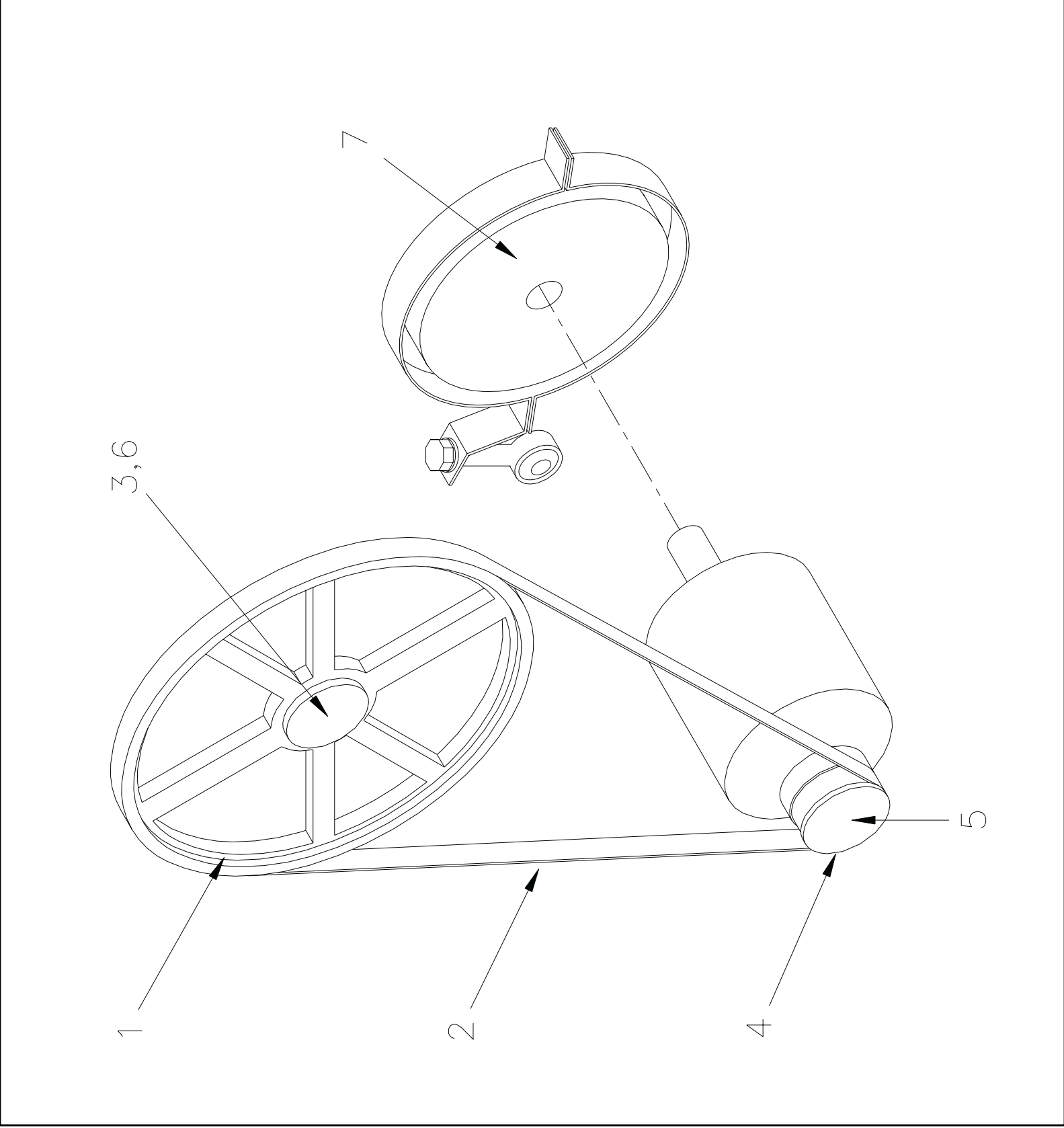

Parts List—Drive Chart
Find the correct assembly first, then find the needed components. The item letters (A, B, C, etc.) assigned to assemblies are referred to in the "Used In" column to identify which components belong to an assembly. The item numbers (1, 2, 3, etc.) assigned to components relate the parts list to the illustration.

Used In	Item	Part Number	Description	Comments
	A	D33 03260	ASSEMBLIES DRIVE CHART=3015/22V4 60CYC	
			COMPONENTS	
all	1	562240R3SF	VPUL 3G3V22.4 (SF) MTO SPECIAL	
all	2	56VR082XB3	VBAND 3R3VX820 EA = 1 BELT	
all	3	56Q1KSF	1+1/2" BUSH VPUL QD TYPE SF	
all	4	560260R3JA	VPUL 3G3V2.60 QD TYPE JA	
all	5	56Q0RJA	7/8" BUSHING VPUL QD TYPE "JA"	
all	6	15E230	STRMACHKEY 3/8SQX2+1/2 TOL.+0	
all	7	54H164A	CLUTCH 12VDC MAPM02	

**Motor Mount
30015 & 30022C4E**



Pellerin Milnor Corporation
P. O. Box 400, Kenner, LA 70063-0400

Litho in U.S.A.

BMP020053/2002446V
(Sheet 1 of 2)

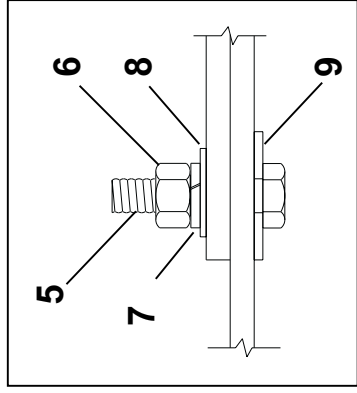

**DETAIL A
(4 PLACES)**

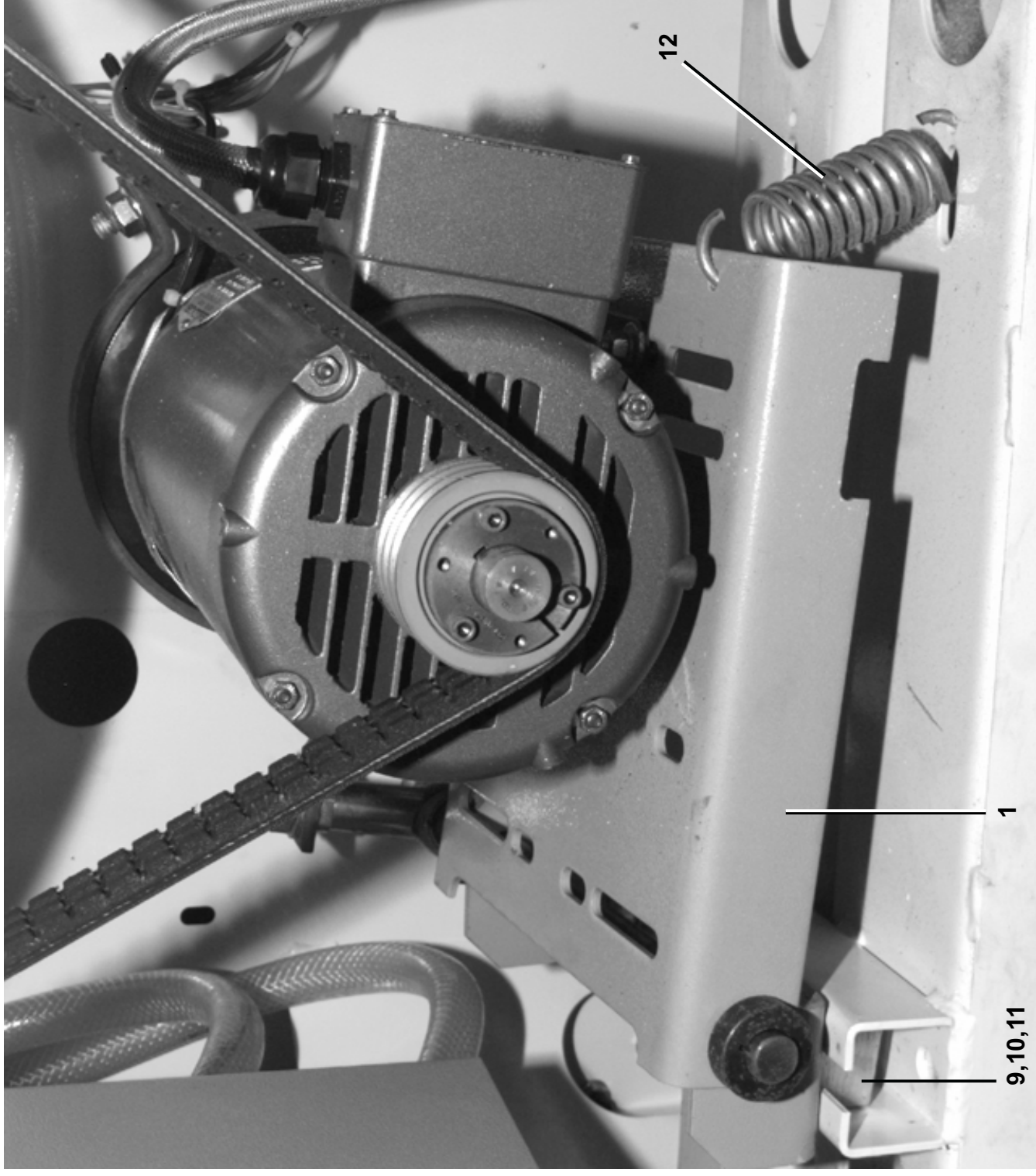
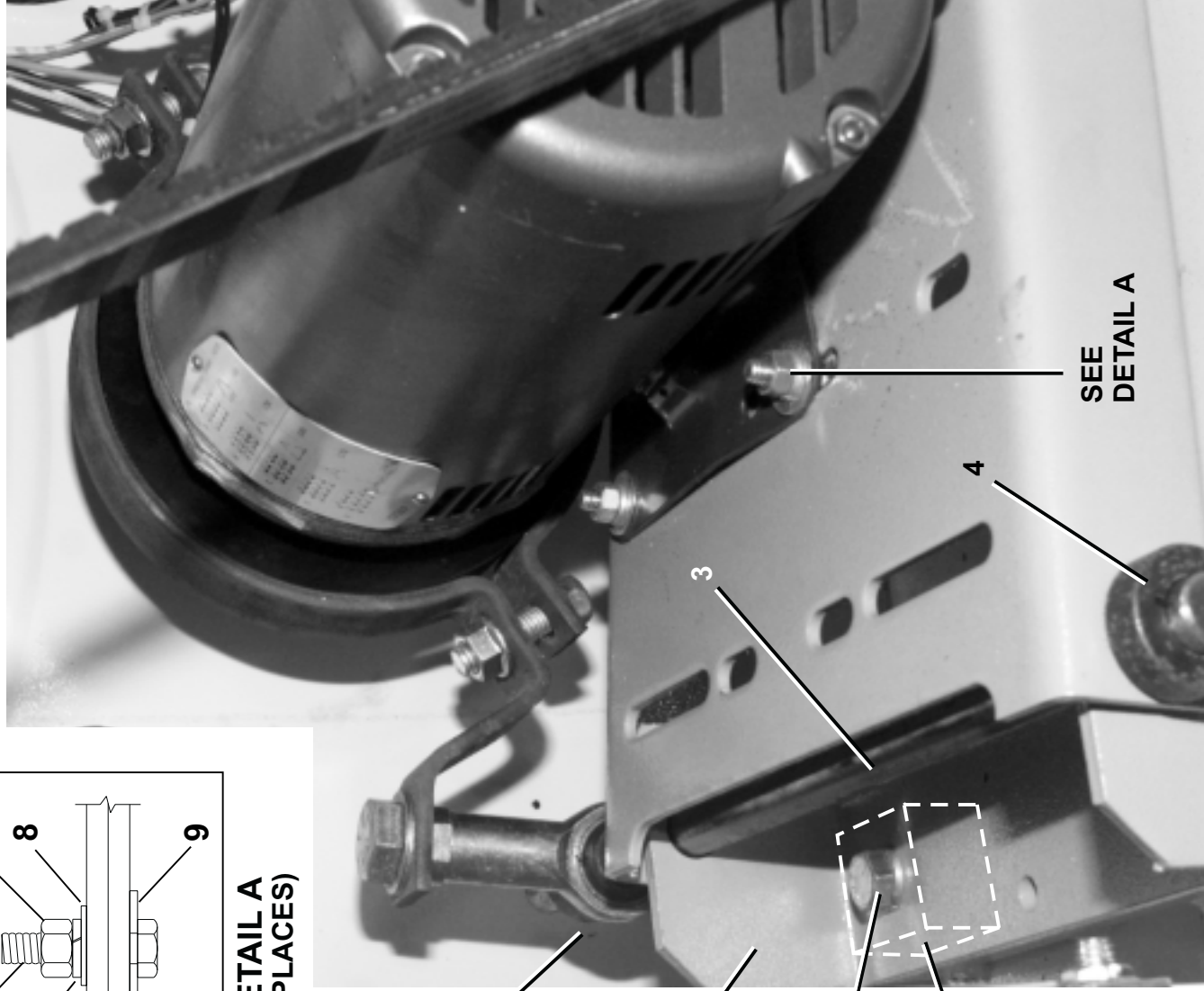



Pellerin Milnor Corporation
P. O. Box 400, Kenner, LA 70063-0400

Litho in U.S.A.

Parts List—Motor Mount

Find the correct assembly first, then find the needed components. The item letters (A, B, C, etc.) assigned to assemblies are referred to in the "Used In" column to identify which components belong to an assembly. The item numbers (1, 2, 3, etc.) assigned to components relate the parts list to the illustration.

Used In	Item	Part Number	Description	Comments
			-----ASSEMBLIES-----	
	A	GDB30001	30" DRIVE BASE SNGL MTR INSTAL	
			-----COMPONENTS-----	
all	1	02 04256	PLATE=MOTOR MNT, 3022S4	
all	2	02 04257A	BRKT=MOTOR MOUNT 30V	
all	3	02 04258	SHAFT=MOTOR MOUNT, 3022S4	
all	4	54JH10750C	SHFTCOLLAR 3/4" CLPTYP CFG#12S	
all	5	15K092Z	HEXFLGSCR 3/8-16X1 GR5 ZINC	
all	6	15G198	HXFLGNUT 3/8-16 ZINC	
all	7	15U255	LOCKWASHER MEDIUM 3/8 ZINCPL	
all	8	15U240	FLATWASHER(USS STD) 3/8" ZNC P	
all	9	15U241	FLATWASHER 13/32IDX1+3/4ODX14G	
all	10	02 19283	NUT=1/2-13UNCX1+1/2SQ SPEC	
all	11	15K162	HXCAPSCR 1/2-13UNC2AX1.5 GR5 P	
all	12	15U300	LOKWASHER REGULAR 1/2 ZINC PLT	
all	13	02 04259	SPRNG/MOT MOUNT/3022S4#SPC2690	

Clutch Brake

3010, 3015CGE ; 30015, 30022C4E



Pellerin Milnor Corporation
P. O. Box 400, Kenner, LA 70063-0400

BMP020054/2004103V
(Sheet 1 of 1)

Litho in U.S.A.

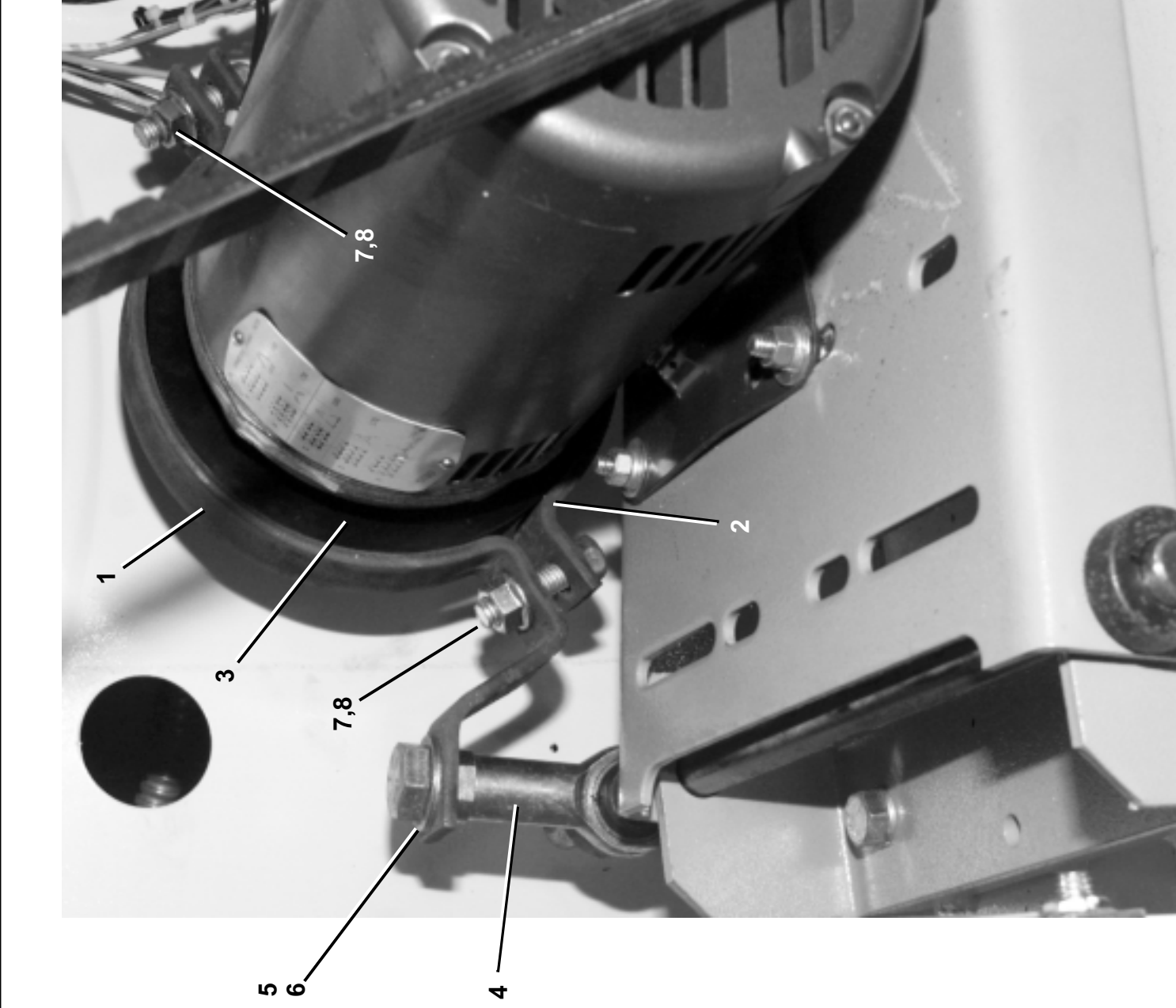

Parts List—Clutch Brake
Find the correct assembly first, then find the needed components. The item letters (A, B, C, etc.) assigned to assemblies are referred to in the "Used In" column to identify which components belong to an assembly. The item numbers (1, 2, 3, etc.) assigned to components relate the parts list to the illustration.

Used In	Item	Part Number	Description	Comments
			-----ASSEMBLIES-----	
A		GBR30001	3022C4E BRAKE INSTALL	
			-----COMPONENTS-----	
	1	04 20257	BRAKE SHOE-TOP -SHUTTLE	
all				
	2	04 20369A	BRAKE SHOE-BOTTOM 30XX COIN	
all				
	3	54AA00PFRE	FEM ROD END ALIN#VF-12G 3/4"	
all				
	4	54H164A	CLUTCH 12VDC MAPM02	
all				
	5	15K230	HXCPC-3/4-16X1+3/4 GR8 ZINC	
all				
	6	15U321H	FLTWASH 3/4 HARD ASTM F436	
all				
	7	15K154H	INDHEXFLGSCR 1/2-13X1+3/4GR8ZN	
all				
	8	15G225H	HEXFLGNUT 1/2-13 SERRATED 18-8	

Section
Bearing Assemblies

3

REPLACING MAIN BEARINGS AND SEALS ON 30015, 30020, 30022Cxx, Kxx, Sxx, AND Mxx MODELS

⚠ DANGER ⚠



ELECTROCUTION HAZARD—High voltage is present inside electric boxes, motors, and many other components, even when Master switch is off and/or any emergency stop is off. You can be killed or seriously injured on contact with high voltage.

- ☞ **Lock OFF and tag out power at the wall disconnect before servicing.**
- ☞ **Maintenance must be performed by qualified, authorized service personnel.**

Oil or water dripping from the leak-off, or water in the bearing oil indicates leaking seals. Bearing oil containing metal particles indicates damaged bearings. Ordinarily, only the shell front and cylinder need to be removed to replace the seals and bearings. Replacing the entire bearing housing assembly or a major bearing housing component requires removal of the shell.

Maintenance procedures require:

- Cylinder puller kit P/N PK33-008 (or equivalent) available from Milnor[®] on a rental or purchase basis.
- Loctite 242, 271, and 504 adhesives, Dow Corning RTV 732, and Permatex 2 (or equivalents).
- Shell clamps.

Removing the Shell Front and Cylinder

Refer to “CYLINDER + SHELL + BEARING + CONSOLE INSTALLATION . . .” (see Table of Contents) and proceed as follows:

1. Remove the door interlock housing cover. Mark the terminal position of the wires and remove the wires from the *interlock switch*. Loosen the two conduit connections and move the conduit so the shell front can be removed.
2. Remove all shell attachments including pipes, hoses, and optional equipment. Drain oil from the bearing housing and inspect.
3. Remove the shell mount ring clip guard located on the top of the shell clamp ring, then mark the position of the shell front with respect to the shell.
4. Support the shell front and remove the bolts, shell clamp ring, rubber extrusion, and shell front.
5. Remove the shaft retainer bolt, cover, spacer, and the two allen screws covering the puller mounting holes. Mount the puller and remove the cylinder.

Replacing Seals with Bearing Housing In Place

NOTE: See the appropriate bearing assembly drawing.

If no water or metal particles are present in drained oil, replace seals and o-rings as follows. If bearing oil contains water or metal particles, see “Replacing Bearings with Bearing Housing in Place” below.

1. Remove front shaft seal holder (push-off holes are provided).
2. Inspect the shaft seal sleeve for nicks, gouges, or excessive wear. If a replacement is necessary, heat and tap the damaged sleeve off of the shaft. Before installing the new sleeve, ensure that the shaft and sleeve are clean and free from oil. Apply Loctite 271 to the inside of the sleeve, tap sleeve onto the shaft, then remove excess Loctite.
3. Replace the seals and o-rings. Apply Loctite 271 to the outside of the seals and install in shaft seal holder. Ensure that the new seals are parallel within the shaft seal holder. Use Loctite 242 when re-installing the front seal holder bolts.

Replacing Bearings with Bearing Housing In Place

NOTE: Set bearing clearances only if major components of the original bearing housing (front shaft seal holder, rear seal/bearing holder, shaft, or shims) are replaced. See “Setting Clearances” in this section after replacing major components.

Often, the bearing housing does not need to be removed to change the bearings. Remove the shell and bearing housing only if insufficient space exists for the following procedures, or if the bearing housing (or housing major components) must be replaced:

1. Remove the front shaft seal holder and rear seal/bearing holder (containing the rear bearing). Note the position and number of shims under the rear seal/bearing holder. **The shims must be installed exactly as removed.**
2. Remove the main shaft, front bearing, and bearing cup through the front of the bearing housing. Remove and discard used bearings, cups, seals, and o-rings.
3. Install a new seal, bearing, and cup in the rear seal/bearing holder. Install the shims and rear seal/bearing holder.
4. Press a new front bearing on the shaft then guide the shaft into the rear seal/bearing holder. **Do not scrape the new bearings against the inside of the bearing housing.**
5. Center the shaft within the housing, then gently tap in the front bearing cup. Install the front shaft seal holder. The shaft should turn in the housing.

Setting Clearances

NOTE: This procedure is required only when a major bearing housing component is replaced. See “Removing and Re-installing the Shell and Bearing Housing” below.

1. Remove all shims from the rear seal/bearing holder. Install the rear seal/bearing holder. Leave a small gap between the bearing housing and the rear seal/bearing holder.
2. Insert a lead wire (e.g., soldering wire) in the gap between flanges. Tighten each bolt slowly while turning the shaft. Stop tightening when the shaft just begins to drag or bind. Remove the rear seal/bearing holder, **being careful not to mark or damage the lead wire.**
3. Using a micrometer, measure the thickness of the lead wire. Add .002" (.050 millimeters) to the thickness of the lead wire and install the rear seal/bearing holder using this amount of shims. The shaft should turn in the housing.

Removing and Re-installing the Shell and Bearing Housing

Replacing the entire bearing housing assembly or a major bearing housing component requires removal of the shell.

Removing the Shell

NOTE 1: 30015 front bearing housing bolts are provided with self-locking nuts.

NOTE 2: 30020 and 30022 shell back clamp rings have three push-off holes to aid in removal. Replace the three plastic set screws with three bolts then tighten evenly to separate the ring from the shell.

1. Clamp the shell to the frame before removing the shell bolts (as shown in FIGURE 1).
2. Remove the self-locking nut and clamp used to secure the level switch sensor hose to the shell mounting screw. Remove all shell bolts, front bearing housing bolts (do not remove the rear bearing housing bolts), and shell back clamp ring, then remove the shell (and bearing housing reinforcing plate if so equipped) from the frame.
3. Remove the belt guard and the top console cover by prying out the four plugs and removing the bolts. Loosen and remove the main drive belts (and *centrifugal switch* if so equipped), and the main drive pulley. For further information see “DRIVE TRAIN SERVICE” (see Table of Contents).

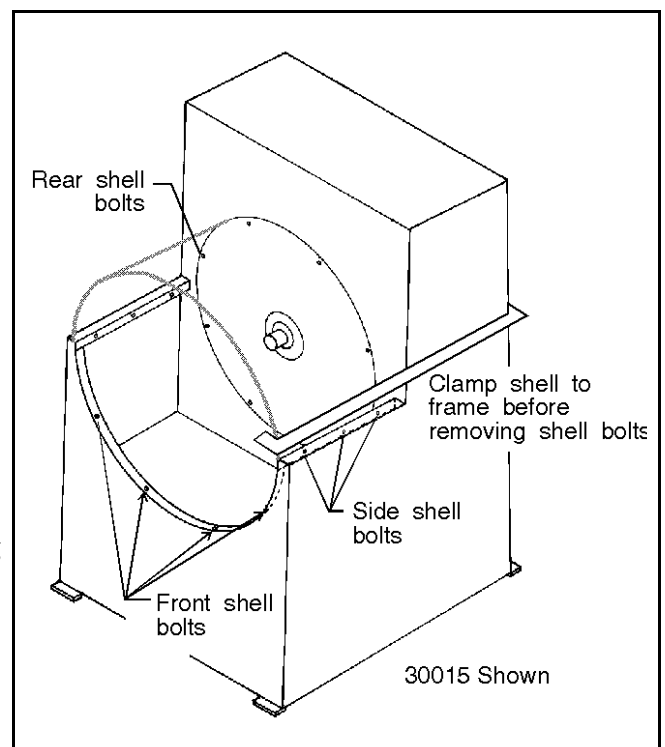

FIGURE 1 (MSSM0708BE)
Clamping the Shell

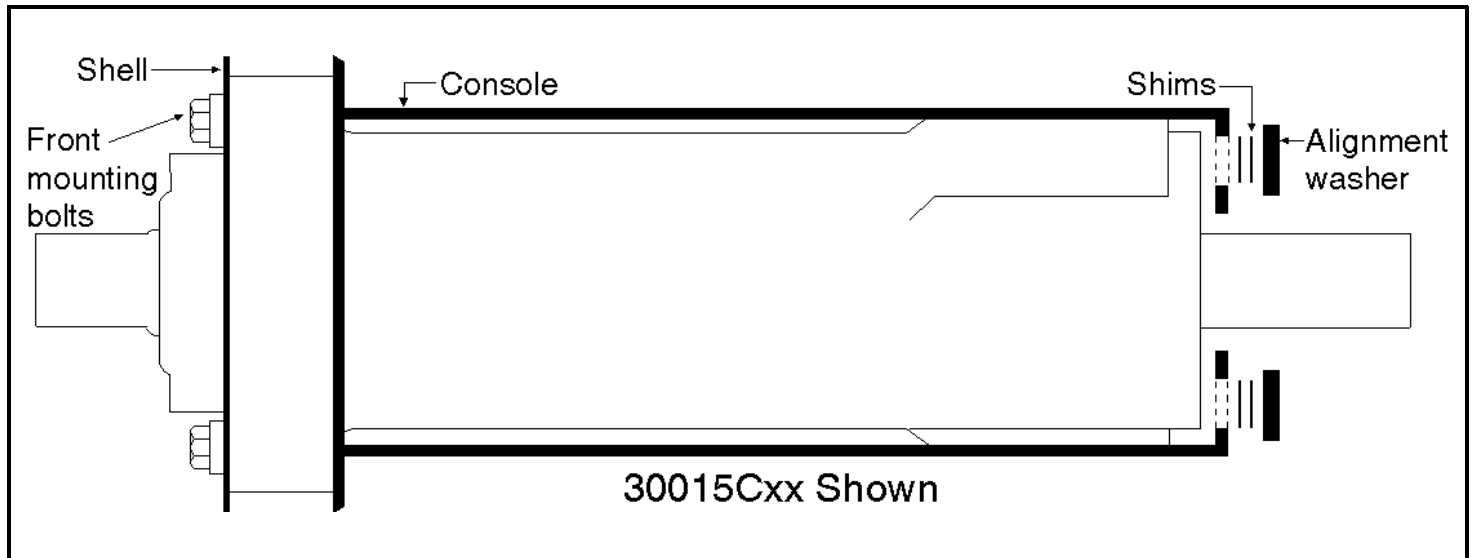

FIGURE 2 (MSSM0708BE)
Typical Main Bearing Mounting

Removing the Bearing Housing

NOTE 1: Shims (shown in FIGURE 2) are factory installed between the bearing housing and the alignment washers. **These shims must be removed and replaced in their exact original positions.**

NOTE 2: 30015M6 models are equipped with a rear reinforcing plate (see FIGURES 4 and 6). Use 30020 and 30022 instructions when removing and installing the bearing housings on these models.

Drain the oil from the bearing housing and remove all fittings and connections from the top and bottom of the bearing housing; then follow the procedure for your machine.

On 30015 Machines—Considerably loosen, but do not fully remove the two rear bearing housing mounting bolts.

1. Pry the bearing housing out of the console until the rear mounting bolts bottom out.
2. Remove the rear mounting bolts one at a time and catch the shims with your fingers through the holes in the rear console member (next to the bearing housing). **Note the position of the shims; they must be replaced in the same position.**
3. Remove the bearing housing from the frame. Grind off the alignment washers as shown in FIGURE 3 and discard old alignment washers.
4. Grind the rear console smooth in preparation for main bearing re-installation.

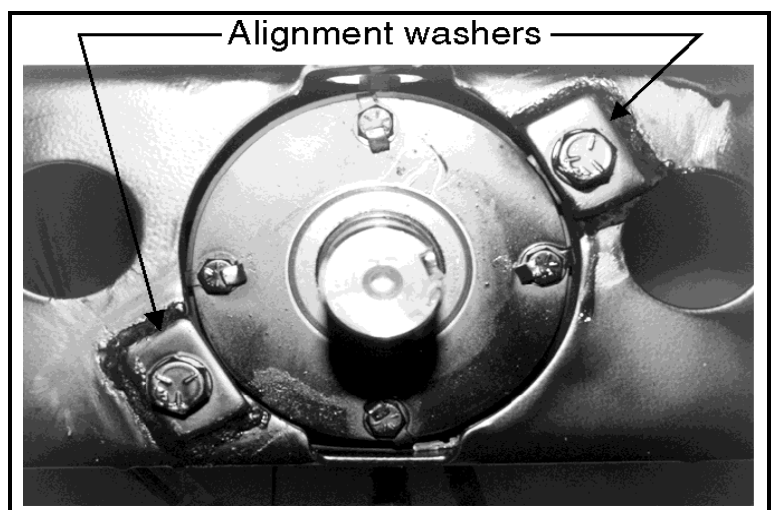

FIGURE 3 (MSSM0708BE)
Alignment Washers
30015 Models (see Note 2 above)

On 30020 and 30022 Machines—Remove the rear bearing housing and rear reinforcing plate mounting bolts.

1. Remove the rear reinforcing plate very carefully, noting the position of bearing support tap strips and shims. **Note the position of the shims; they must be replaced in the same position.**
2. Remove the bearing housing from the frame. Remove plate and grind off the alignment washers (as shown in FIGURE 4). and discard old alignment washers.
3. Grind rear reinforcing plate smooth in preparation for main bearing re-installation.

Installing the Bearing Housing and Shell

NOTE 1: Use new bolts when reassembling the machine.

NOTE 2: Apply Permatex 2C adhesive (or equivalent) to both sides of the new bearing housing gaskets.

NOTE 3: Install a new NYLTITE washer and nut gasket on each new shell bolt (see FIGURE 5).

On 30015 Machines—Replace the four J-type nuts along the rim of the front console with new clips.

1. Determine that all threaded holes are clean and in good condition by screwing a new bolt into each hole (if necessary, tap out any damaged threads).
2. Position the bearing housing in the console.
3. Mount the gasket on the front of the bearing housing.
4. Determine that the shell is clean and free from any old gasket material, then mount the shell onto the console using new shell bolts (FIGURE 5).
5. Using drift pins, install the rear shell bolts first (FIGURE 1), then tighten to draw the shell into place.
6. Install all other shell bolts and tighten evenly. Liberally apply Dow Corning RTV 732 sealant over the inside shell bolts and washers.
7. Mount the gasket and the new ring to the inside of the shell.
8. Install the front bearing mounting bolts through the ring and bearing housing, and tighten front bolts. Install new alignment washers and original shims on rear mounting bolts (FIGURE 2). **Replace the shims on rear mounting bolts exactly as removed.**

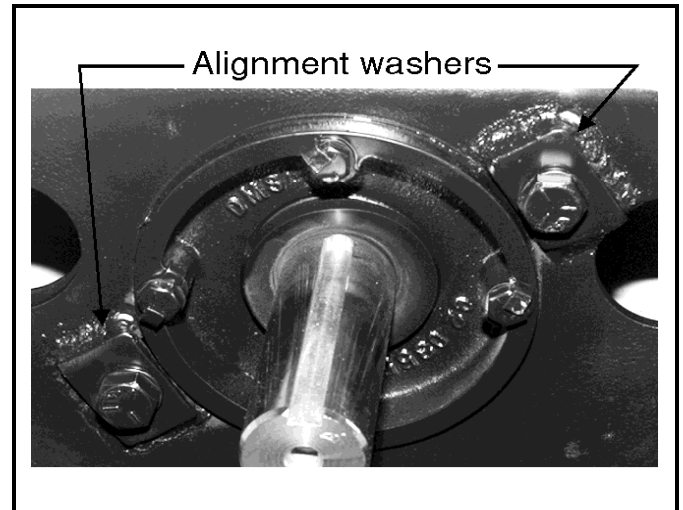

FIGURE 4 (MSSM0708BE)
Alignment Washers
30020 and 30022 Models

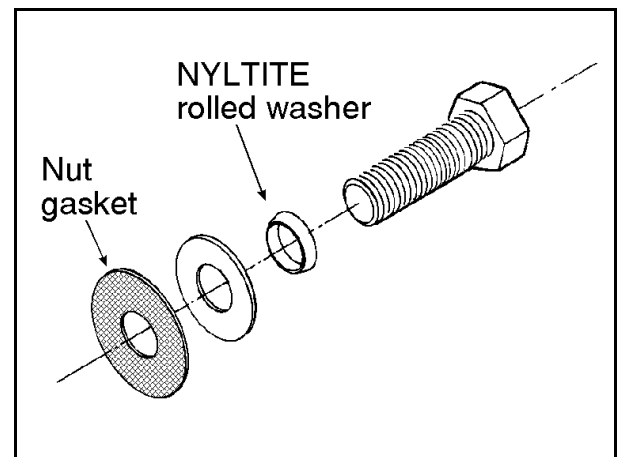

FIGURE 5 (MSSM0708BE)
Shell Bolt

9. Tighten bolts. Insure there is approximately .0625 inch (1.6 mm) clearance between the alignment washers and the console as shown in FIGURE 7. Add or subtract shims as required to obtain the specified clearance. Weld the new alignment washers to the console.
10. Install all of the original lubrication fittings and connections to the new bearing housing.
11. Secure the level switch sensor hose using a new clip and self-locking nut.

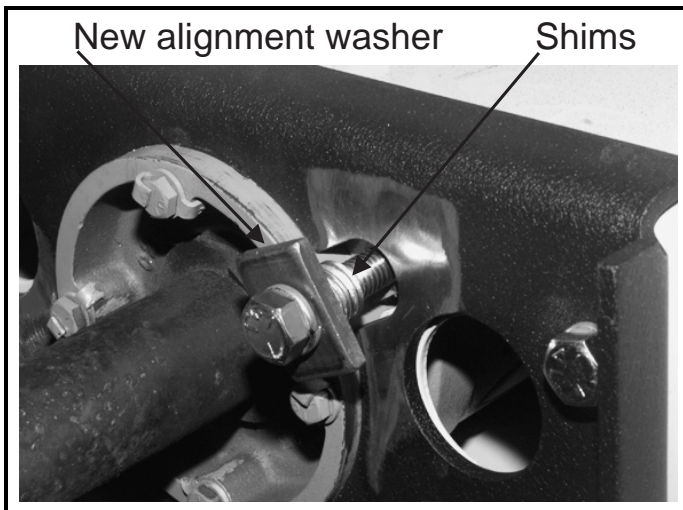

FIGURE 6 (MSSM0708BE)
Installing New Alignment Washers

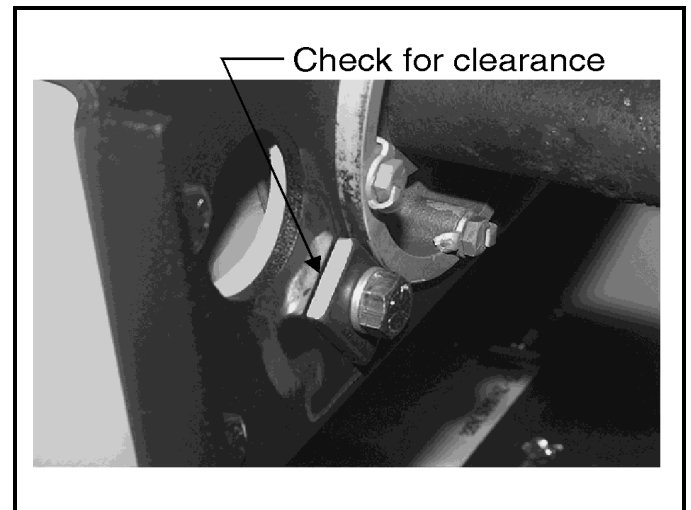

FIGURE 7 (MSSM0708BE)
Alignment Washer to Console

On 30020 and 30022 Machines—Replace the four J-type nuts and determine that all threaded holes are clean and in good condition.

1. Position the bearing housing in the console.
2. Mount the gasket, housing reinforcing plate, and second gasket.
3. Determine that the shell is clean and free from any old gasket material, then using new shell bolts (FIGURE 5), mount the shell onto the console.
4. Mount the gasket and ring to the inside of the shell.
5. Using Loctite 504, install the front bearing housing bolts and lockstraps through the ring and the bearing housing. Tighten the bolts and bend the lockstraps as applicable.
6. Pre-position the two bearing support tap strips, then install the rear reinforcing plate. Install new alignment washers and original shims on rear mounting bolts (FIGURE 6). **Replace the shims on rear mounting bolts exactly as removed.**
7. Tighten bolts. Insure there is approximately .0625 inch (1.6 mm) clearance between the alignment washer and the reinforcing plate as shown in FIGURE 7. Add or subtract shims as required to obtain specified clearance. Weld the new alignment washers to the reinforcing plate.
8. Install all of the original lubrication fittings and connections to the new bearing housing.
9. Secure the level switch sensor hose.

Installing the Cylinder and Shell Front

1. Screw two new allen screws into the cylinder puller mounting holes; **do not obstruct the shaft retainer spacer seat.**
2. Determine that the main shaft is clean and free from any foreign material and that the key is properly seated.

⚠ CAUTION ⚠

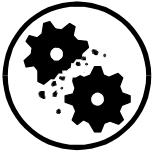

Failure to properly install cylinder may cause it to loosen during machine operation. This will cause damage to the cylinder, shell, and main bearing shaft surfaces.

☞ **Carefully follow cylinder installation step below.**

3. Slide the cylinder onto the shaft, and install a new 3/4" inch long 3/4-10 grade 8 zinc plated bolt and washer. Carefully tighten this bolt, using it to pull the cylinder up the tapered main bearing shaft. After cylinder is in place, torque the bolt to 282 foot pounds (382 Newton meters).

Remove the grade 8 bolt and replace with a new 3/4" inch 18-8 stainless steel retainer bolt and washer with the original cover and spacer. Torque the retainer bolt to 150 foot pounds.

4. Determine that the shell front and front lip of the shell is clean and free from burrs, sharp edges, or sealants.

⚠ CAUTION ⚠

A metal hammer can crack stainless steel components.

☞ **Do not use a metal hammer to seat the shell front or install the ring.**

5. Using clamps, mount and support the shell front in place (align it with the mark made before it was removed). If necessary, use a rubber or rawhide maul to strike the shell front so it seats within the shell. After the shell front is seated properly on the shell, check the gap between the shell front and the lip on the shell. If necessary, use a rubber or rawhide maul on the shell lip to close the gap.
6. Pack a small amount of Permatex 2 adhesive (or similar) into the top center gap of the shell front and shell, two inches on both sides of the shell weld.
7. Install the new rubber extrusion starting at the 10 o'clock position. Trim off any excess.
8. Install the shell clamp ring on the shell front with the ring gap at the top center of the shell. Tap around the ring (bottom to top) with a rubber maul until a clamp can be installed on the ends of the shell clamp ring. Repeat this procedure and tighten the clamp until the bolt can be installed. Tap around the ring again, and tighten the bolt. Install the shell mount ring clip guard.
9. Reconnect door interlock conduit and wires.
10. See "DRIVE TRAIN SERVICE" (see Table of Contents) to replace pulleys, belts, and to set belt tension.

Cylinder, Shell, Bearing, and Console Installation

30015 & 30022 Rigid Mount Washer Extractors

BMP020001/2002446V
(Sheet 1 of 2)



Pellerin Milnor Corporation
P. O. Box 400, Kenner, LA 70063-0400

Litho in U.S.A.

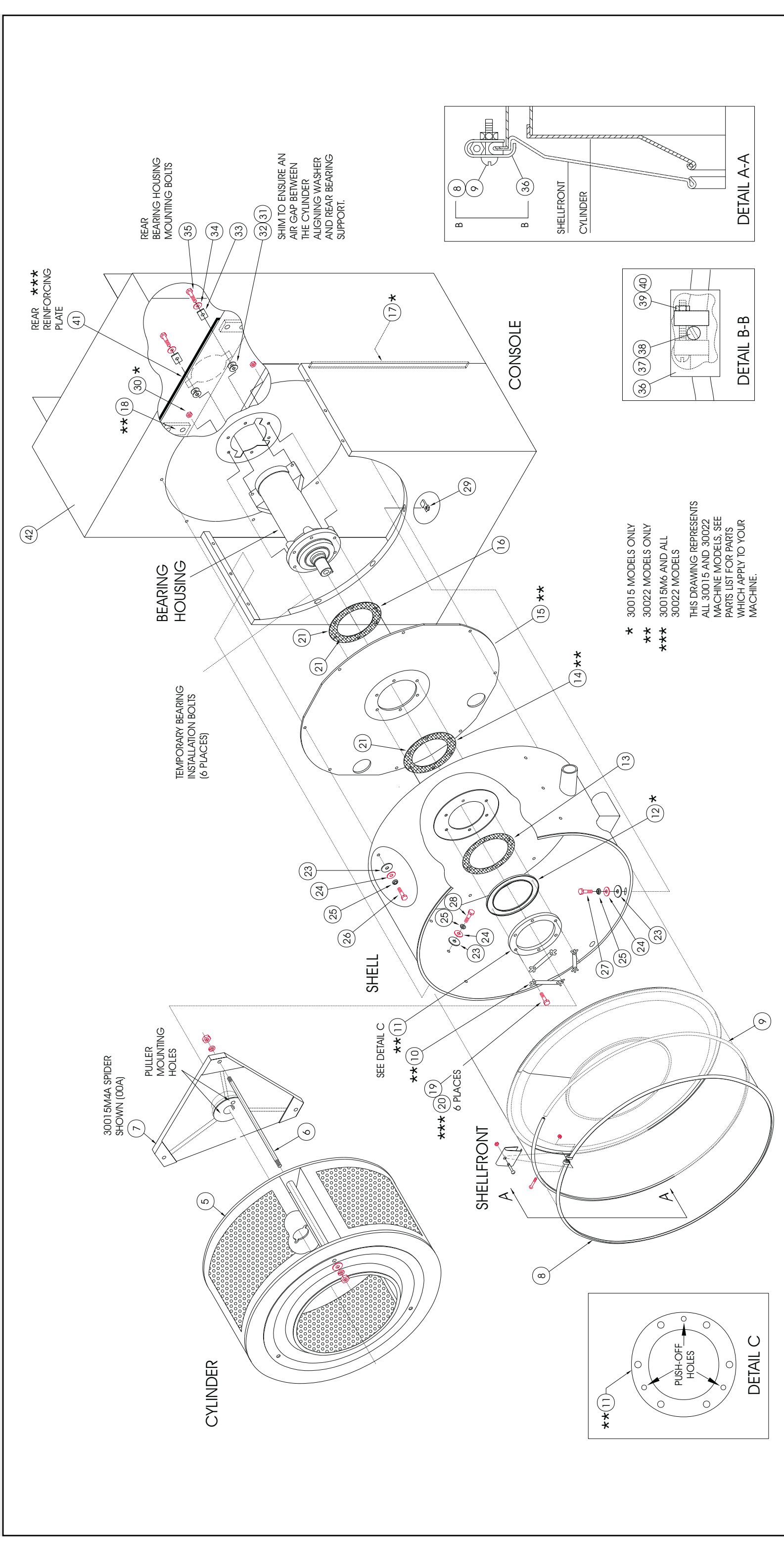

* 30015 MODELS ONLY
 ** 30022 MODELS ONLY
 *** 30015M6 AND ALL 30022 MODELS

THIS DRAWING REPRESENTS ALL 30015 AND 30022 MACHINE MODELS. SEE PARTS LIST FOR PARTS WHICH APPLY TO YOUR MACHINE.



Parts List—Cylinder, Shell, Bearing, Console Installation
Find the correct assembly first, then find the needed components. The item letters (A, B, C, etc.) assigned to assemblies are referred to in the "Used In" column to identify which components belong to an assembly. The item numbers (1, 2, 3, etc.) assigned to components relate the parts list to the illustration.

Used In	Item	Part Number	Description	Comments
			ASSEMBLIES	
	A	ACA02CWE	CYL ASSY=3015CWE/NMA/C4M/OE	30015C4A,C4T,C4E
	B	ACA33C6M	* CYL ASSY=3015C6M	30015T5J,T5E
	C	ACA3022M5	*CYL ASSY=3022 M5/C/K/S	30015V7J
	D	ASH33008	SHELL+CONSOLE 3015C4-MICRO	30022C4A,C4T,C4E
	E	ASH33035	SHELL+CONSOLE 3022C4	30022V6J,30022T5J
	F	ASH3022V5	ASSY=SHELL+CONSOLE, 3022V5	30015C4A,C4T
	G	ASH33040	SHELL+CONSOLE 3015V7	30022C5X
	H	ASC30001	3022C4E FRONT/REAR CONSOLE ASY	30022V5J,T5J
	J	ASC30002	3015C4E FRONT/REAR CONSOLE ASY	30015V7J,30015T5J
			COMPONENTS	30022C4E
				30015C4E
all	1	15B200	HEXCAPSCR 3/4-10X1+3/4 SS18-8	
all	2	15U350	LOCKWASHER 3/4 MED SS18-8	
all	3	02 11196	COVER=SHAFT RETAINER=304S/S	
all	4	02 14359A	SHAFT RETNR SPACER 2+3/4" SQ	
A	5	ACA02CWE	CYL ASSY=3015CWE/NMA/C4M/OE	
B	5	ACA33C6M	* CYL ASSY=3015C6M	
C	5	ACA3022M5	*CYL ASSY=3022 M5/C/K/S	
all	6	02 02138A	CYLTIEROD-3/3015W+CWU 18-8SS	
all	6	02 03703J	CYLINDER TIE ROD 3022S5	
all	7	X2 02758	SPIDER=1/CWU+25W	
all	7	X2 03561	SPIDER=C6M ONLY-CASTIRON	
all	7	X2 03561A	SPIDER C5M	
all	8	Y2 02059	*SHELL CLAMP RING=30" MACHINE	
all	9	02 02087C	EXTRUS*ION-SHELL=30" MACHINES (
all	10	02 03629	LOCKSTRAP=BEAR HOUS S/S	
all	11	X2 03576	RING=SHELL BACK CLAMP=1/C6M	
all	12	02 03444	RING=SHELL BACK CLAMP	
all	13	02 03446	1 GASKET=SHELLBACK CLAMP RING	
All	13	02 03575	GASKET=SHELLBACKCLAMP RING=CWM	
all	14	02 03574	GASKET=MAIN BEARINGHOUSE=CWM	
all	15	02 03568	PLATE-BG HOUSING REINFORCING	
all	16	02 03574	GASKET=MAIN BEARINGHOUSE=CWM	
all	16	02 03335	GASKET BEARING HOUSING CWE	
all	17	02 03749	BAR=REINF STRIP 3015	
all	18	02 03560	TAPSTRIP=BEARING SUPPORT	
all	19	15K126	HEXCAPSCR 3/8-16NCX2+1/2SS18-8	
all	19	15K196	HEXCAPSCR 1/2-13UNC2X3 18-8SS	
All	20	20C013C	GSKT ELIM.250CC LCT#504-41	
all	21	20C036A	PERMATEX NO 2C IN 11 OZ TUBES	
all	22	15K182	HEXTAPSCR 1/2-13XZINC GR5 FUL	
all	23	02 02293	DOOR HANDLE NUT GASKET	

Used In	Item	Part Number	Description	Comments
all	24	15U245	FLT WASH 3/8 STD COMM 18-8 SS	
all	25	24G030N	ROLLED WASH.379ID NYLTITE 37W	
all	26	15K096	HEXCAPSCR 3/8-16UNC2X1SS18-8	30015
all	26	15K100	HEXCAPSCR 3/8-16X1+1/4 SS18-8	30022
All	27	15K086	HXCAPSCR 3/8-16NCX3/4 SS18-8	
all	28	15K086	HXCAPSCR 3/8-16NCX3/4 SS18-8	30015
all	29	17N071	NUT J-TYPE T#C33952-3816-3B 3/	
all	30	15G218	HXLK NUT NYL 3/8-16 STL/ZNC	30015
all	31	15U245	FLT WASH 3/8 STD COMM 18-8 SS	
all	32	15U312	FLAWASHER 3/4ODX33/64IDX11GA Z	
all	33	02 03397	CYLINDER ALIGNING WASHER	
all	34	15U300	LOK WASHER REGULAR 1/2 ZINC PLT	
all	35	15K182	HEXTAPSCR 1/2-13XZINC GR5 FUL	
all	36	02 02181	GUARD=SHELL MOUNT RING CLIP	
all	37	15K046S	HEXCAPSCR 1/4-20UNC2A X 2.25 S	
all	38	15G168	SQ NUT 1/4-20UNC2 SS18-8	
all	39	15N146	RDMACHSCR 10-24UNC2X1 SS18-8	
all	40	15G130	HEXMACHSCR NUT 10-24UNC2 SS18-8	
all	41	02 03559	SUPPORT=REAR BRG HOUSE	
D	42	W2 03769B	WLMT=REARCNLSLE 3015C4 REAR H2O	
E	42	W2 03771B	WLMT=CONSOLE 3020C4A REAR H2O	
F,G	42	W2 03770B	WLMT=REAR CONSOLE, 3022V5	
H	42	W2 03771C	WLMT=3022C4E REAR CONSOLE	
J	42	W2 03769C	3015C4E REAR CONSOLE WELD	

Main Bearing Assembly
30015C4A, C4T, C4E, M4x, K5x, S5x

BMP910032/2002446V
 (Sheet 1 of 2)



Pellerin Milnor Corporation
 P. O. Box 400, Kenner, LA 70063-0400

Litho in U.S.A.

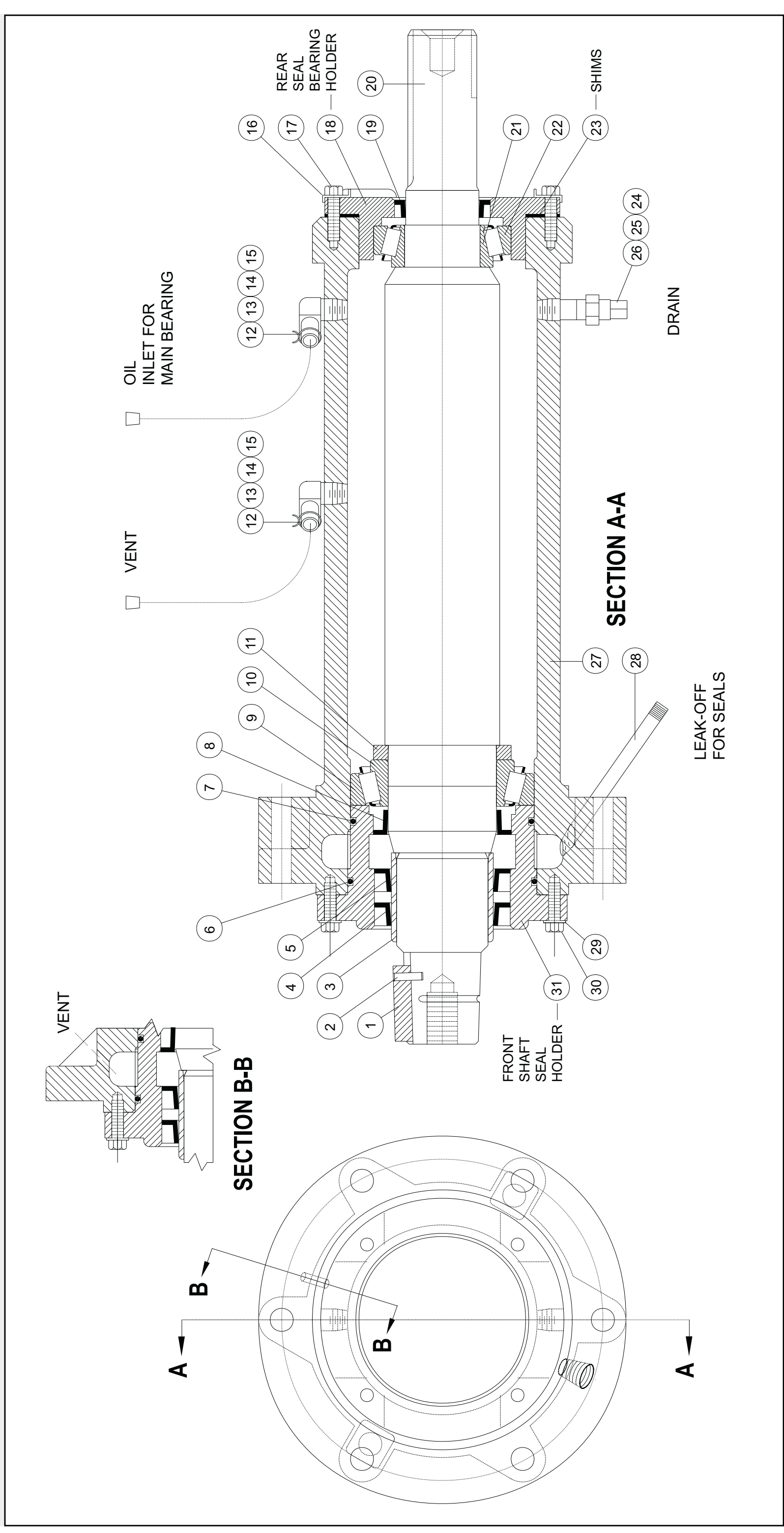



Pellerin Milnor Corporation
P. O. Box 400, Kenner, LA 70063-0400

Litho in U.S.A.

Parts List—Main Bearing Assembly
Find the correct assembly first, then find the needed components. The item letters (A, B, C, etc.) assigned to assemblies are referred to in the "Used In" column to identify which components belong to an assembly. The item numbers (1, 2, 3, etc.) assigned to components relate the parts list to the illustration.

Used In	Item	Part Number	Description	Comments
	A	SA 33 030	* MAIN BEARASY 3015CWE+NMA+C4	
	B	SA 33 030V	MAIN BEARASY 3015C4/M4-VITON	VITON
			-----ASSEMBLIES-----	
			-----COMPONENTS-----	
all	1	02 02294A	SHAFT KEY 3/8 X 3/8	
all	2	15H089S	SPRINGPIN 1/8"DIA X 5/8" LONG	
all	3	02 03311	SEAL SLEEVE OUR MATL	
A	4	24S005	SEAL 2.25 X 3.0 X .375 SS BUNA	
B	4	24S005V	SEAL2.25X3.0X.375#022510289LUP	
A	5	24S005	SEAL 2.25 X 3.0 X .375 SS BUNA	
B	5	24S005V	SEAL2.25X3.0X.375#022510289LUP	
all	6	60C151	ORING 3+7/8ID1/8CS BUNA70#241	
all	7	60C150	ORING 3+3/4ID1/8CS BUNA70 #240	
all	8	24S015	SEAL 2.265X3.256X.433 CR#23678	
all	9	54A319	CUP 28920 TIMKN 2-24 1/BX+PT#	
all	10	54A320	CONE 28985 TIMKN 2-51 1/BX+PT#	
all	11	02 03392	BEARING BACKUP WASR OILCOAT	
all	12	5SLOEBEC	NPTSELB 90DEG STRT 1/4 BRASS125	
all	13	03 01142	NIPPLE 1/4X1+1/4 BRASS	
all	14	27A043A	HOSECLAMP.562"DIA.SPRG#HC9STZD	
all	15	60E005P	PVC TUBING 1/2"ID X 5/8"OD	
all	16	02 03407	LOCKING WASHER ZINC PLATE	
all	17	15K095	HXCPCSR 3/8-16UNC2AX1 GR5 ZINC	
all	18	X2 03660	HOUSE=SEAL+BRG-24S048AAA CWU	
all	19	24S048AAA	SEAL 1.625X2.375X.375 CS/BUNA	
all	20	X2 03314	MAIN SHT=3015CWE NMA C4M C6M	
all	21	54A306	CONE 24780 TIMKN 2-51 1/BX+PT#	
all	22	54A305	CUP 24720 TIMKN 2-24 1/BX+PT#	
all	23	02 03323	SHIM=.003 CRS GREEN	AS REQUIRED
all	23	02 03323A	SHIM=.005 CRS BLUE	AS REQUIRED
all	23	02 03323B	SHIM=.010 CRS RED	AS REQUIRED
all	23	02 03323C	SHIM=.0075 CRS BLACK	AS REQUIRED

Parts List, cont.—Document Name

Used In	Item	Part Number	Description	Comments
all	23	02 03323D	SHIM=.020 CRS WHITE	
all	23	02 03323E	SHIM=.050 CRS CLEAR	
all	24	5SP0EFFSSM	NPT PLUG 1/4 SQSLDMAGNET BLKST	
all	25	5N0E01KBE2	NPT NIP 1/4X1.5TBE BRASS STD.	
all	26	5SCC0EBE	NPT COUP 1/4 BRASS 125# W/HEX	
all	27	X2 03436	HOUSING-MAIN BEARING=1/CWU	
all	28	5N0E05AG42	NPT NIP 1/4X5 TBE GALSTL SK40	
all	29	02 03564	BOLT LOCKING TAB 1/4 BOLT	
all	30	15B080	HEXCAPSCR 5/16 X1+1/4 SS-18-8	
all	31	X2 03437	HOLDER=SHAFT SEAL=1/CWU	

Main Bearing Assembly 30020 & 30022

BMP910033/2002446V
(Sheet 1 of 2)



Pellerin Milnor Corporation
P. O. Box 400, Kenner, LA 70063-0400

Litho in U.S.A.

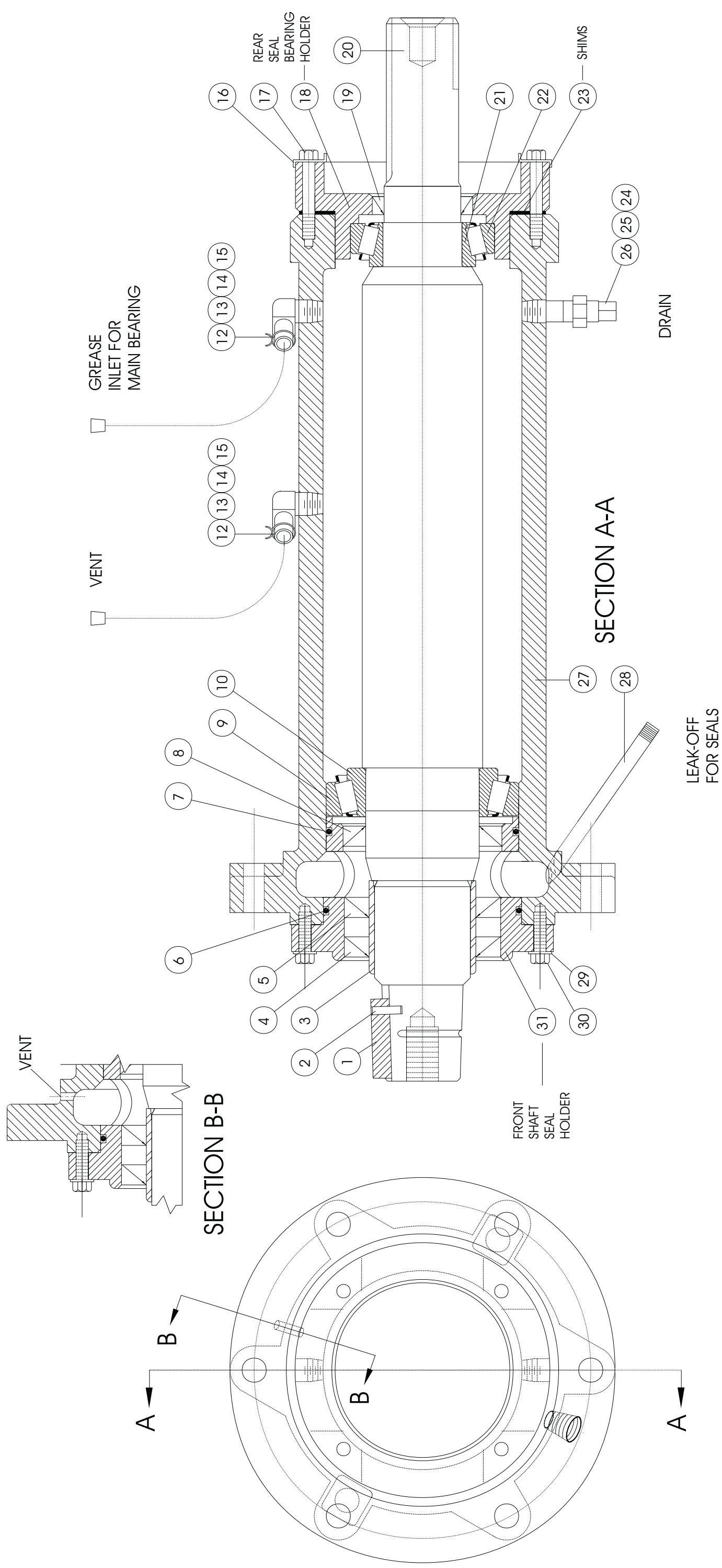



Used In	Item	Part Number	Description	Comments
	A	A33 09901	* BEARING ASSY=C5M + N4M	30020M4A,C4A,C4E M5X+30022M4X,M5X, C5X,S5X,K5X
	B	ABM33001	BEARING ASSY=3020M7	30020M7X
	CC	A33 09901V	MAIN BEARASY 3020C4/M5-VITON	30020M4A,C4A,C4E M5X+30022M4X,M5X, C5X,S5X,K5X OPTIONAL VITON
			-----ASSEMBLIES-----	
			-----COMPONENTS-----	
all	1	15H089S	SPRINGPIN 1/8"DIA X 5/8" LONG	
all	2	02 02294A	SHAFT KEY 3/8 X 3/8	
all	3	02 13143	SEALSLEEVE=SWE-1/SWE	
AB	4	24S053	SEAL 2.625X3.625X.437#10050LUP	
C	4	24S053V	SEAL 2.625X3.625X.437#10050LUP	
AB	5	24S053	SEAL 2.625X3.625X.437#10050LUP	
C	5	24S053V	SEAL 2.625X3.625X.437#10050LUP	
all	6	60C151	ORING 3+7/8ID1/8CS BUNA70#241	
all	7	60C151	ORING 3+7/8ID1/8CS BUNA70#241	
all	8	24S052A	SEAL 2.559X3.55X.315 CR#25430	
all	9	54A916	CUP TIMKN#JLM710910 1/BX+PT#	
all	10	54A915	CONE TIMKN#JLM710949C 1/BX	
all	12	5SLOEBEC	NPTSELB 90DEG STRT 1/4 BRASS125	
all	13	03 01142	NIPPLE 1/4X1+1/4 BRASS	
all	14	27A043A	HOSECLAMP.562"DIA.SPRG#HC9STZD	
all	15	60E005P	PVC TUBING 1/2"ID X 5/8"OD	
all	16	02 03407	LOCKING WASHER ZINC PLATE	
all	17	15K127	HEXFLGSCR 3/8-16X2 GR8 CS	
all	18	X2 03659A	HOUSE=SEAL+BRG 30M,V7	
all	19	24S048AAA	SEAL 1.625X2.375X.375 CS/BUNA	
all	20	X2 13103A	SHAFT,MAIN FOR 3020C5M+N4M	
all	21	54A308	CONE M802048 TIM 2-24 1/BX+PT#	
all	22	54A307	CUP M802011 TIMK 2-24 1/BX+PT#	

Parts List, cont.—Main Bearing				
Used In	Item	Part Number	Description	Comments
all	23	02 03323	SHIM=.003 CRS GREEN	AS REQUIRED
all	23	02 03323A	SHIM=.005 CRS BLUE	AS REQUIRED
all	23	02 03323B	SHIM=.010 CRS RED	AS REQUIRED
all	23	02 03323C	SHIM=.0075 CRS BLACK	AS REQUIRED
All	23	02 03323D	SHIM=.020 CRS WHITE	
all	23	02 03323E	SHIM=.050 CRS CLEAR	
all	24	5SP0EFFSSM	NPT PLUG 1/4 SQSLDMAGNET BLKST	
all	25	5N0E01KBE2	NPT NIP 1/4X1.5TBE BRASS STD.	
all	26	5SCC0EBE	NPT COUP 1/4 BRASS 125# W/HEX	
AC	27	X2 03573A	HOUSING BEARING C5M	
B	27	X2 13105A	HOUSING=MAIN BEARING 3020M7	
all	28	5N0E05AG42	NPT NIP 1/4X5 TBE GALSTL SK40	
all	29	02 03564	BOLT LOCKING TAB 1/4 BOLT	
all	30	15B080	HEXCAPSCR 5/16 X1+1/4 SS-18-8	
all	31	X2 13144A	HOLDER=SHFT SEAL(05=24S052A)	

Find the correct assembly first, then find the needed components. The item letters (A, B, C, etc.) assigned to assemblies are referred to in the "Used In" column to identify which components belong to an assembly. The item numbers (1, 2, 3, etc.) assigned to components relate the parts list to the illustration.

Section

4

Shell and Door Assemblies

Shellfront Assembly, Conduit, & Interlock

3010 / 3015 G5E,G5X,CGE

30015 V7J,T5J,C4A,C4E & 30022 V6J,T5J,C4A,C4E

BMP920024/2004055V
(Sheet 1 of 2)



Pellerin Milnor Corporation
P. O. Box 400, Kenner, LA 70063-0400

Litho in U.S.A.

FOR DOOR
ASSEMBLY, SEE
BMP920009.

FOR INTERLOCK
ASSEMBLY, SEE
BMP750046.

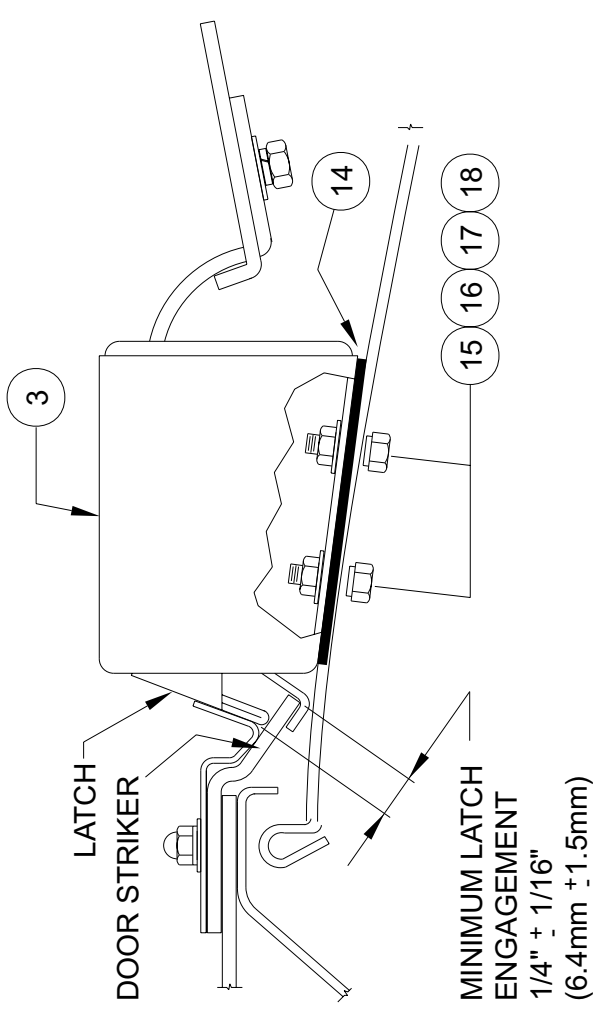
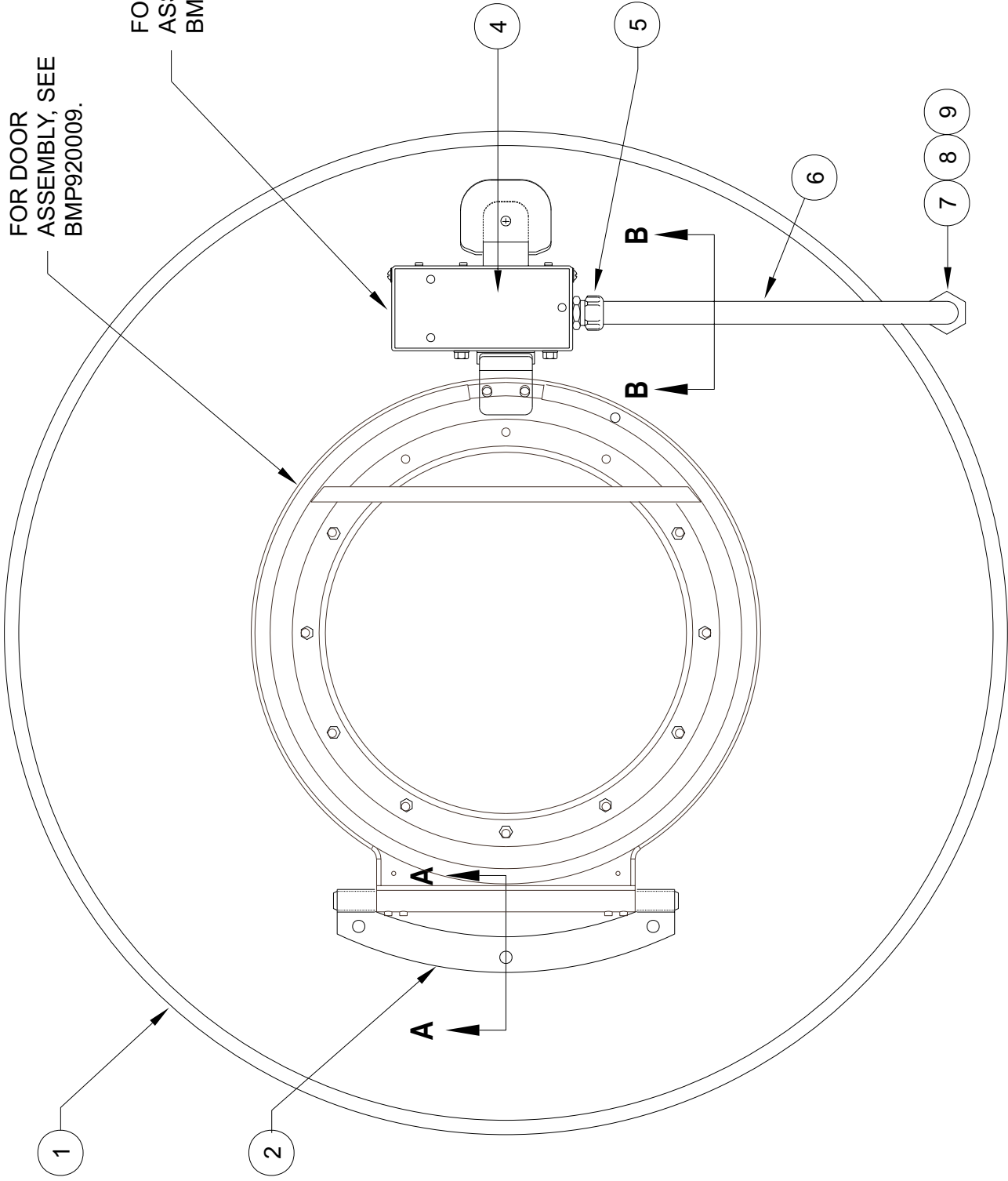

VIEW "B-B"

ADJUSTMENTS:

1. ADJUST DOOR STRIKER SO THAT IT TOUCHES THE LATCH SQUARELY AND EVENLY.
2. ADJUST THE LATCH SO THAT THE MINIMUM ENGAGEMENT WITH THE DOOR FULLY CLOSED EQUALS 1/4" ± 1/16" (6.4mm ± 1.5mm).

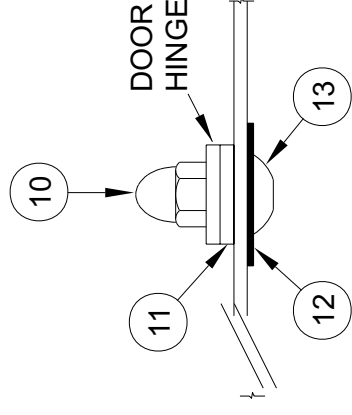

VIEW "A-A"



Pellerin Milnor Corporation
P. O. Box 400, Kenner, LA 70063-0400

Litho in U.S.A.

Parts List—Shellfront, Conduit & Interlock
Find the correct assembly first, then find the needed components. The item letters (A, B, C, etc.) assigned to assemblies are referred to in the "Used In" column to identify which components belong to an assembly. The item numbers (1, 2, 3, etc.) assigned to components relate the parts list to the illustration.

Used In		Item	Part Number	Description	Comments
-----ASSEMBLIES-----					
A		A33 10100C		*SHLASSY (IDNT) UNLOK N4P	3015M4G/J/P, M6J,D4A 3022M5G/J
B		A33 10100H		SHELL FRONT ASSY 3015/20M4A	3015M4A, C4T, M4T, M6A, M6T 3022M5T, 3022C4T
C		A33 10100M		SHLASSY N/LOCK 3015/22S#G/J	3022S4J, S4G, S5J 3015K4A, S4J, S5G, S5J
D		A33 10100N		SHLASSY N/LOCK 3015/22V/T	3010G5E, G5X 3015G5E, G5X, V7J, T5E, T5J, T5X 3022V6J, T5E, T5J, T5X
E		A33 10100F		*SHLASSY (IDNT) UNLOK C4A	3015C4A, 3022C4A
F		A33 10100G		SHLFR TASY N/O ILOK W/PROX	3010CGE, 3015CGE, 30015C4E 30022C4E
-----COMPONENTS-----					
ABCDE	1	X2 02361B		SHELLFRONT, 30" ELECTRIC LOCK	
F	1	X2 02361C		2002296D SHELLFR T=30" ILOC W/PROX	
A,C,D	2	A33 07100C		*DRASSY (INDNT) LK, LOGO N4, 5, 6P	
B	2	A33 07100H		95027 DOOR ASY 3015/3020M4A	
EF	2	A33 07100F		95027# DRASSY (INDNT) LK, LOGO C4A	
A,B	3	EDL00171		INTRLKHSG ASSY=N/UNLOCK 240V	
C	3	EDL00371		INTRLKHSG=N/LOCK+SWITCH240V	
D	3	EDL00271		INTRLKHSG ASSY=N/LOCK 220V	
F	3	EDL00171C		INTRLKHSG ASSY=N/O W/ PROX 240	
all	4	01 10422		NPLATE: DOOR ILOC->N4, 5, 6 P	
all	5	12K040		1/2" COND. EMT COND. PECO #260B	
All	6	03 01446		1/2 EMT CONDUIT 900D=DR INTR	
all	7	10Y71M4GEX		*M4G EXTERNAL CONNECTIONS	
all	8	12K040		1/2" COND. EMT COND. PECO #260B	
all	9	12P1ASSB		SNAPBUSH 7/8" MH X 11/16	
all	10	15G200C		HXCPNUT HI 3/8-16 BRASS NIK PL	
all	11	02 02819C		SPACER-SHELLFRONT/HINGE	
all	12	02 02293		DOOR HANDLE NUT GASKET	
all	13	15K084		TRUSS HXSOK 3/8-16 X 23/32SS	
ABCDE	14	02 03669		GASKET=INTRLK HOUSING	
F	14	02 03669C		GASKET=INTRLK HOUSING 8" LONG	
all	15	15N174		HXCAPSCR 1/4-20UNC2X5/8SS18-8	
all	16	15U180		LOCKWASHER MEDIUM 1/4 ZINCPL	
all	17	24G020N		ROLLED WASH. 252ID NYLTITE 25W	

Parts List, cont.—Shellfront, Conduit & Interlock

Used In	Item	Part Number	Description	Comments
All	18	15G168	SQ NUT 1/4-20UNC2 SS18-8	

Door Assembly
3010 / 3015 G5E, G5X, CGE
30015 V7J, T5J, C4A, C4E & 30022 V6J, T5J, C4A, C4E

BMP020002/2004055V
 (Sheet 1 of 2)



Pellerin Milnor Corporation
 P. O. Box 400, Kenner, LA 70063-0400

Litho in U.S.A.

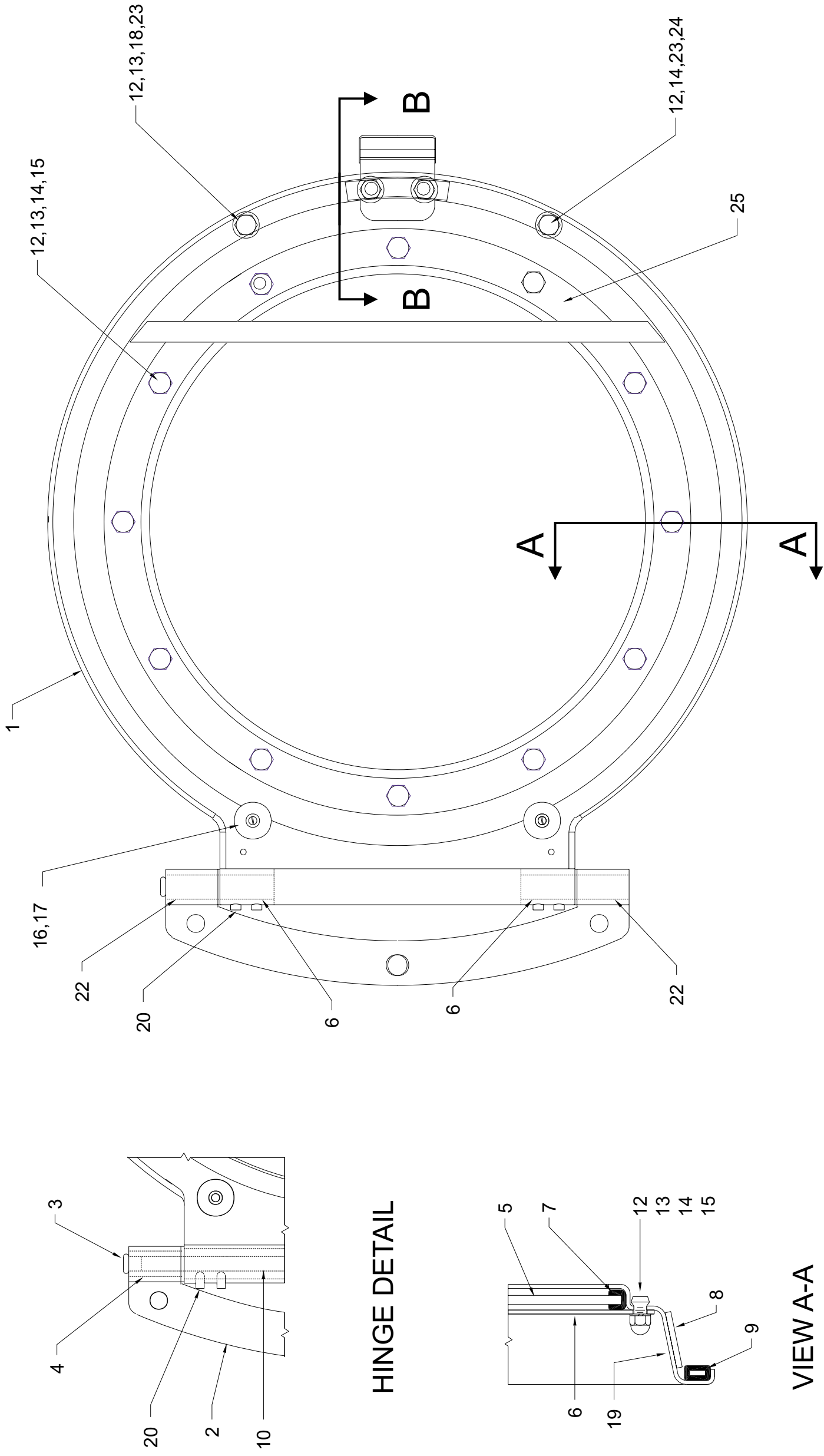

HINGE DETAIL

VIEW B-B

VIEW A-A



Pellerin Milnor Corporation
P. O. Box 400, Kenner, LA 70063-0400

Litho in U.S.A.

Parts List—Door Assembly

Find the correct assembly first, then find the needed components. The item letters (A, B, C, etc.) assigned to assemblies are referred to in the "Used In" column to identify which components belong to an assembly. The item numbers (1, 2, 3, etc.) assigned to components relate the parts list to the illustration.

Used In	Item	Part Number	Description	Comments
-----ASSEMBLIES-----				
	A	A33 07100C	*DRASSY(INDNT)LK,LOGO N4,5,6P	3010/3015 G5E,G5X 3015T5E,T5J,T5X,V7J 3022T5E,T5J,T5X,V6J
	B	A33 07100F	DRASSY (INDNT)LK,LOGO C4A	3010CGE,3015CGE 3015C4T,C4E 3022C4T,C4E
-----COMPONENTS-----				
all	1	X2 02814F	MACH=SHELLDOOR DRAWN, 30XX	
all	2	02 02819	HINGE=STAMPED DOOR 25#	
all	3	12P1AGHP1	HOLEPLUG 3/8"BLACK LPE	
all	4	02 02817	FLANGE BRG=DOOR HINGE-NYLON	
A	5	02 09215	DRGLASS 12 3/8DIA SS STAMPED	
B	5	02 09215D	DR GLASS=N4,5,6P W/MIL LOGO	
all	6	02 09021	RING=DOOR GLASS PRESSURE	
all	7	02 02366	GASKET DOORGLAS GTR52-5220-3	
all	8	02 10545	EXTR BAND-STAMPED SS CYLDOOR	
all	9	02 10342G	GASKET 15" DOOR-BLACK	
all	10	02 02764	HINGEPIN=SHELLDOOR L=10+5/8"	
all	11	03 01420A	DOOR STRIKER=ILOC	
all	12	15G140	HXCAPNT 1/4-20 #C250=20 NKLPLT	
all	13	15K031	BUTSOKCAPSCR 1/4-20X1/2 SS18-8	
all	14	15U181	LOCKWASHER MEDIUM 1/4 SS18-8	
all	15	24G020N	ROLLED WASH.252ID NYLTITE 25W	
all	16	60C080	RECESS BUMPER RUBBERLAVELLE #7	
all	17	15P103	TRDCUT-F RDHDSLOT 8-32UNCX1/2	
all	18	15N173A	FLTMACSCR 1/4-20 UNCX5/8 UCUTS	
all	19	20C018	ADHESIVE-3M #1357-QT CN	
all	20	15Q077	SOKSETSCR 1/4-20X1/4 ZINC ALLE	
all	21	03 01423C	LATCH GUARD ILOC 3015-20	
all	22	02 02815	PLAIN BRG=DOOR HINGE-NYLON	
all	23	15U188	FLTWASH 1/4 STD COMM SS18-8	
all	24	15N191	FLATMACHSCR 1/4-20X7/8 SS18-8	
all	24	15N176	FLATMACSCR 1/4-20NCX3/4SS18-8	
all	25	02 09263	SHIM=SHELLDOOR LATCH, 36XX	
all	26	02 11904K	SHIM=DOOR HANDLE=4226RWP	

Interlock Assembly
30015, 30022, 3621 C4E

BMP020058/2005086V
 (Sheet 1 of 4)



Pellerin Milnor Corporation
 P. O. Box 400, Kenner, LA 70063-0400

Litho in U.S.A.

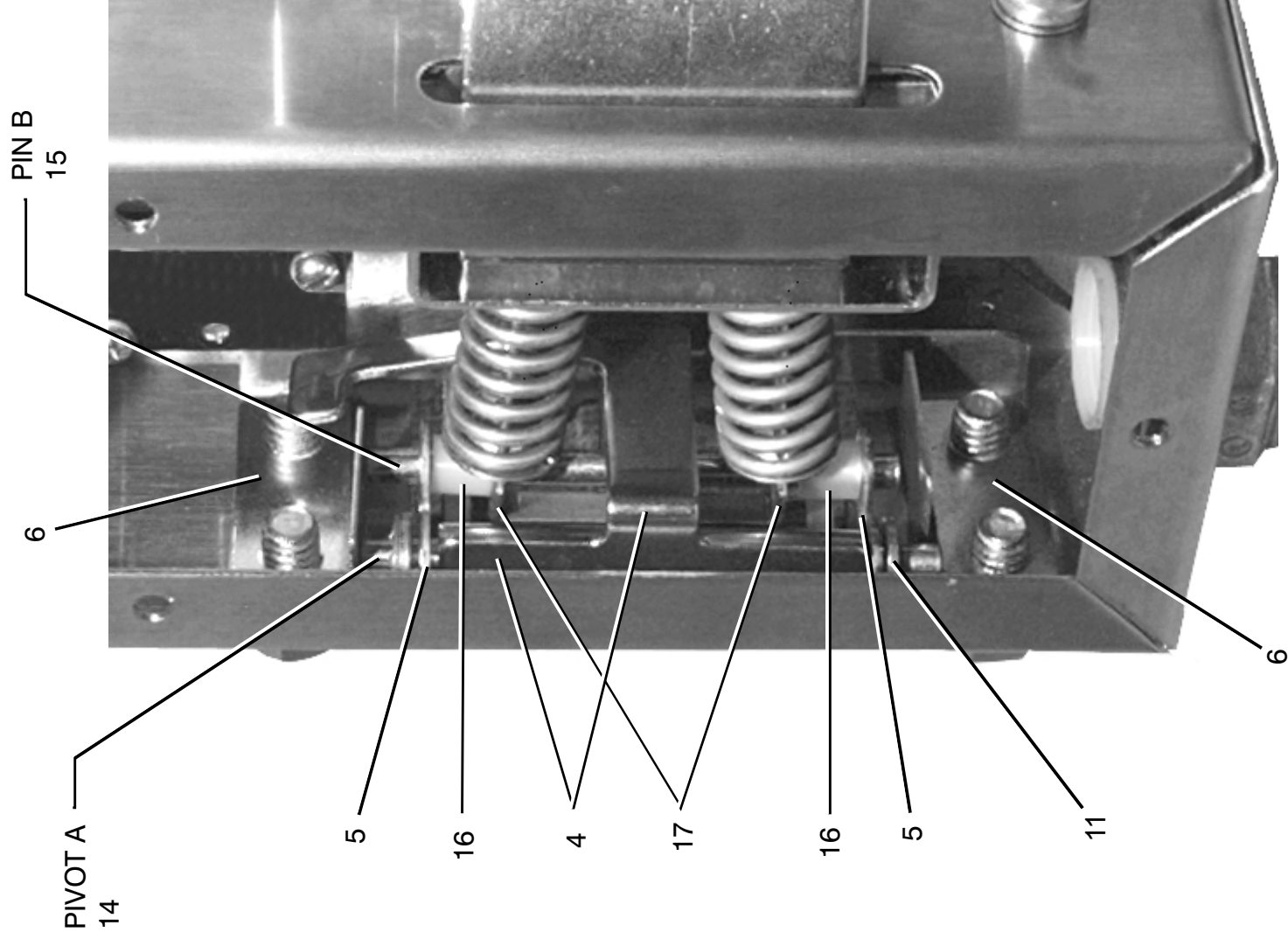
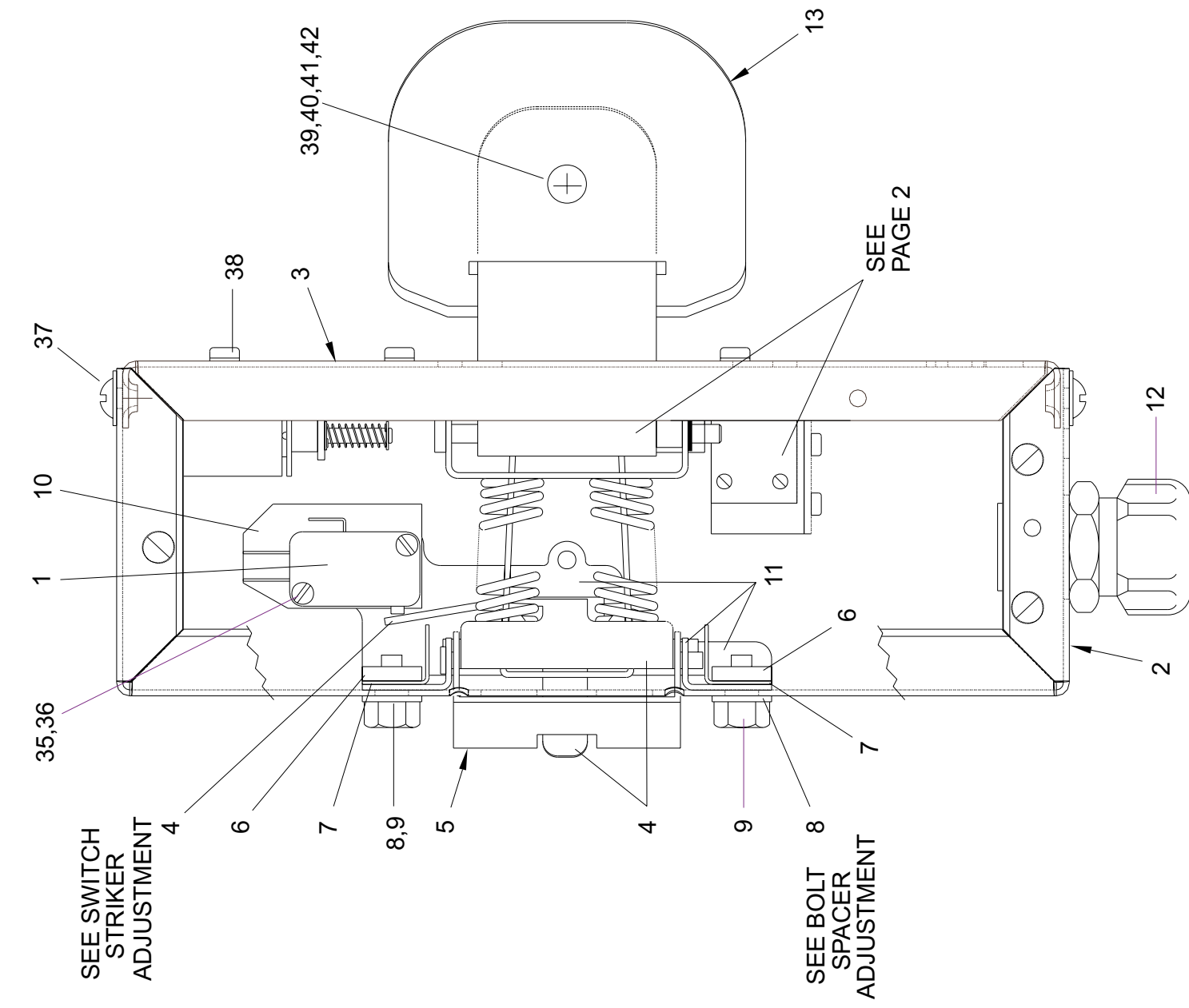

Interlock Assembly 30015 & 30022 C4E

BMP020058/2005086V
(Sheet 2 of 4)



Pellerin Milnor Corporation
P. O. Box 400, Kenner, LA 70063-0400

Litho in U.S.A.

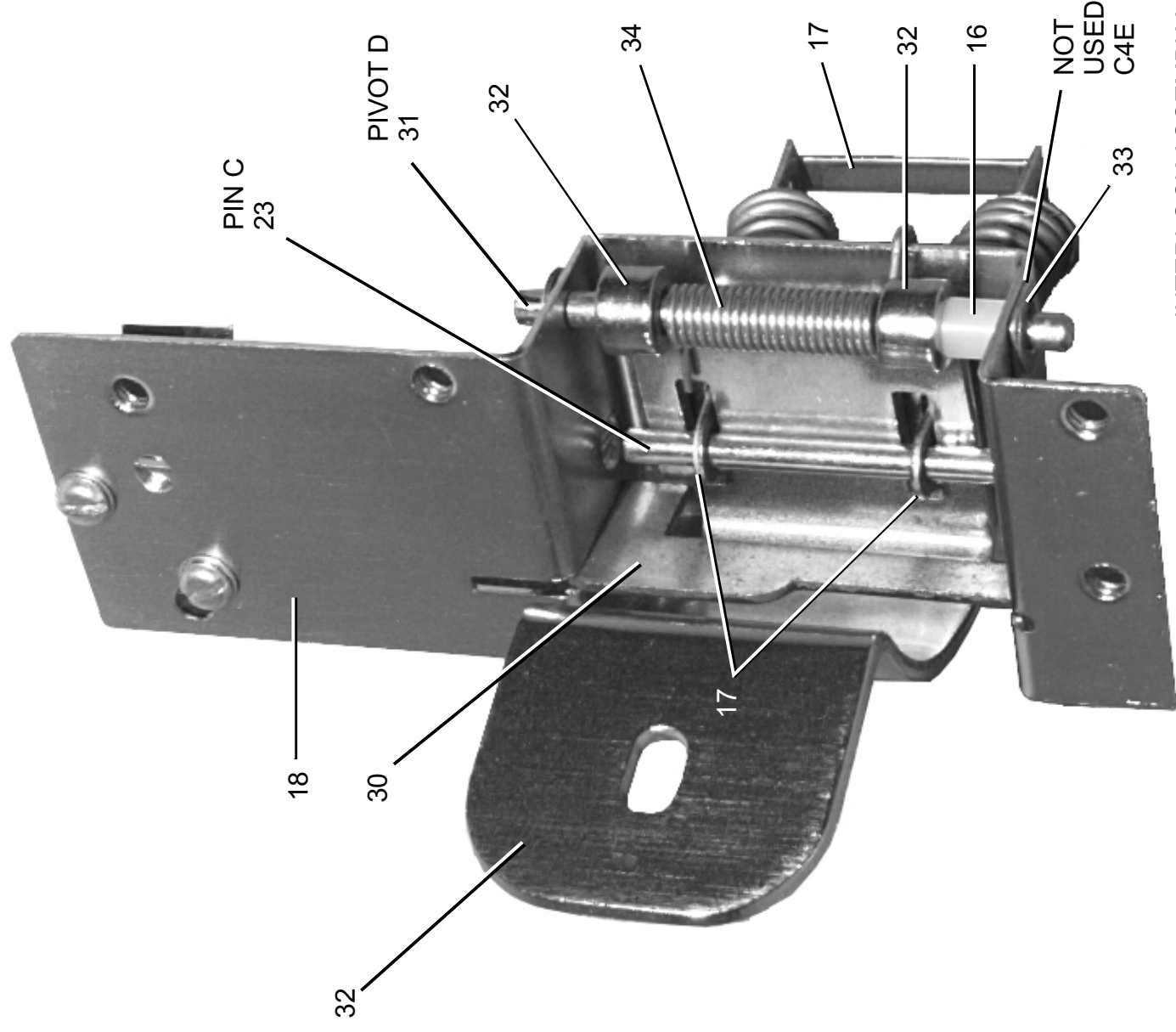

INTERLOCK ASSEMBLY
WITHOUT PROXIMITY
SWITCH SHOWN

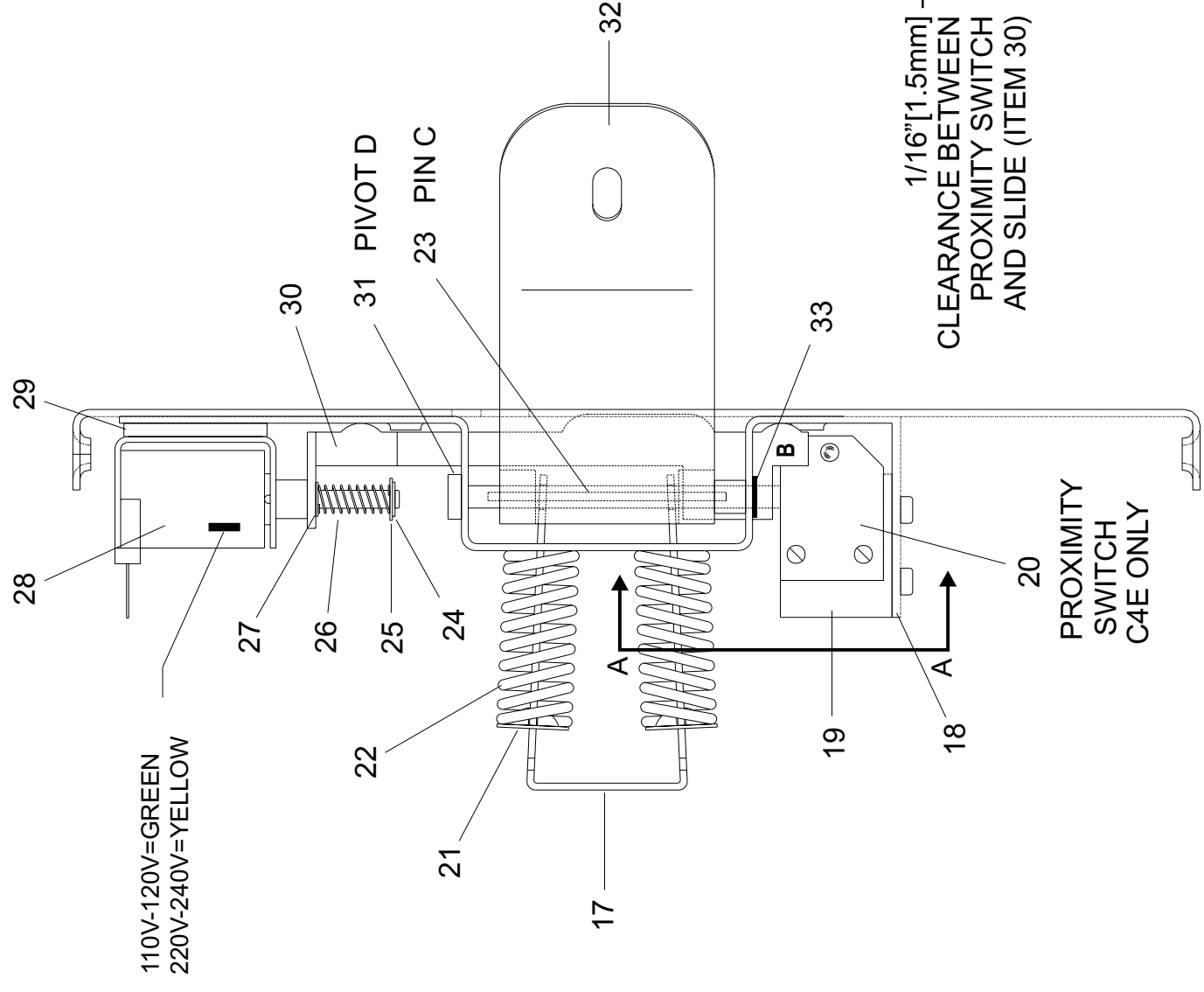

FRONT VIEW

PROXIMITY SWITCH
HAS TWO LED LAMPS:

GREEN = ON / ENERGIZED
ORANGE = CLOSED CIRCUIT

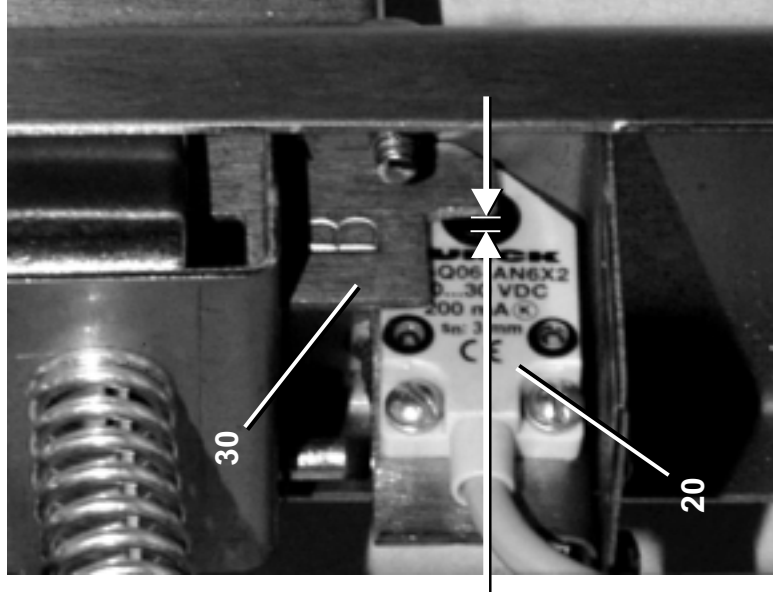

VIEW A-A

1/16" [1.5mm]
CLEARANCE BETWEEN
PROXIMITY SWITCH
AND SLIDE (ITEM 30)

Interlock Assembly 30015 & 30022 C4E



Pellerin Milnor Corporation
P. O. Box 400, Kenner, LA 70063-0400

BMP020058/2005086V
(Sheet 3 of 4)

Litho in U.S.A.

Parts List—Interlock Assembly
Find the correct assembly first, then find the needed components. The item letters (A, B, C, etc.) assigned to assemblies are referred to in the "Used In" column to identify which components belong to an assembly. The item numbers (1, 2, 3, etc.) assigned to components relate the parts list to the illustration.

Used In	Item	Part Number	Description	Comments
			ASSEMBLIES	
A		EDL00171C	INTRKHSG ASSY=N/O W/ PROX 240	3015,3022C4E
B		EDL00171B	ILOC PIVOT ASSY W/PROX 240V	PART OF A
C		EDL00137C	INTRKHSG ASSY=N/O W/PROX 120V	3621C4E
D		EDL00137B	I-LOC PIVOT ASSY=W/PROX 120V	PART OF C
			COMPONENTS	
all	1	09R014A	MINI-SW SPDT STAKON #V15G1C26K	
all	2	03 01426B	HOUSE=REAR ILOC W/PROX	
all	3	03 01427C	HOUSING=REAR ILOC W/PROX	
all	4	03 01424A	STRIKER=SWITCH=LONG TAB	
all	5	03 01423	LATCH = INTERLOCK	
all	6	03 01418B	KEEPER=LATCH PIN/NOTCH	
all	7	03 01418	TAP STRIP = ELEC INTER LOCK	
all	8	03 01417	PLATE=SPACER=ILOC	
all	9	15N158	HEXCAPSCR 1/4-20NCX1/2SS18-8	
all	10	03 01335	INSULATOR=AIROP AUTOSPOT+\$8S	
all	11	03 01429	PLATE=FNT PIVOT = ILOC	
all	12	12K040	1/2"COND.EMT COND. PECO #260B	
all	13	03 01425A	DOOR HANDLE EXTENSION	
all	14	03 01443	FLATHDRIVET 5/32X2+5/16 ZINC	
all	15	15H091	STRGHTPIN 5/32"X2.25 LG ZINC	
all	16	27B205080Z	SPCRROLL.177ID.218L.027T STLZC	
all	17	03 01422	KEEPER=SPRING=ILOC	
all	18	03 01428C	PLT=RR PIVOT ILOC+PROX 220V	
all	19	03 01428B	XROX BKT=REAR PIVOT ILOC N/O	
all	20	09RPS03RDS	3MM SENSING RECTANGULAR SHLD	
all	21	03 01444A	SPRING CUP = ILOC	
all	22	03 01444	SPRING .51/1.69/46+CADPL	
all	23	15H090I	STPIN 5/32 X DIA 1.75"LG ZN.	
all	24	17B171	EXTRETRING IND#6100-9-ST-ZD ZI	
all	25	15U063	FLATWASH STD #6 EXCEPT.010THK	
all	26	03 01445	SPRING .2/625/.319+CADPL	

SWITCH STRIKER ADJUSTMENT

Adjust the switch striker arm by bending as shown so that :

- 1) The switch is activated when the door is closed
- 2) The switch does not actuate when the unlatching lever is fully depressed with the door open
- 3) The arm does not over travel and hit the switch housing when the door is closed and the switch is actuated.

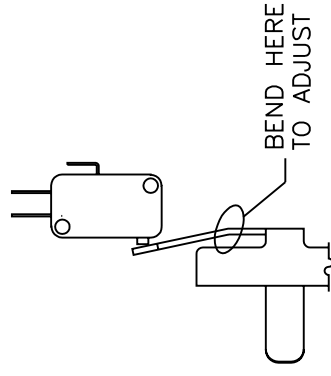

BOLT SPACER ADJUSTMENT

Bolt Spacer Adjustment

- 1) On a new machine the slots on the front housing should not show a gap past the bolt spacers.
- 2) The spacers should be installed with the long side toward the shellfront

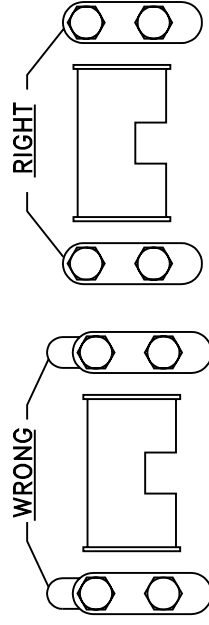



Pellerin Milnor Corporation
P. O. Box 400, Kenner, LA 70063-0400

Litho in U.S.A.

Parts List, cont.—Interlock Assembly

Used In	Item	Part Number	Description	Comments
all	27	15U060	FLAT WASHER#6 ANSI TYPEB BRASS	
B	28	09K062B71	SOLENOID 240/60--220/50 = ILOC	
D	28	09K062B37	SOLENOID(C-7)120/60--110/50	
all	29	03 S1X1	SHIM:DOOR INTLK SOLENOID N4P	
all	30	03 01421B	SLIDE=NORMALLY OPEN(C7 SOL)	
all	31	03 01443	FLATHDRIVET 5/32X2+5/16 ZINC	
all	32	03 01425	HANDLE=ILOC	
all	33	17B170	EXTRETRING IND#6100-15-ST-ZD Z	
all	34	03 01445B	TORQUE SPRING (.53 IN-#)	
all	35	15N019	RDMACSCR 4-40UNC2AX5/8 ZINC GR	
all	36	15U040	LOCKWASHER MEDIUM #4 ZINCPL	
all	37	15N080S	PANHDPHILMACSCRSEMS8-32X1/4SS	
all	38	15P010S	TRDCUTPNHD SEMS 10-24X1/2 SS41	
all	39	15G130	HEXMACHSCRNUT 10-24UNC2 SS18-8	
all	40	15N123C	FLATMACHSCR 10-24X7/16 U-CUT S	
all	41	15U160	LOCKWASHER MEDIUM #10 SS18-8	
all	42	15U135	FLATWASH#10 .4370DX.203IDX.04T	
all	43	03 01442	SOLENOID INSULATION=DR INTRK	

Section
Control and Sensing

5

Switch Panel Assembly
3010 & 3015GCE; 30015, 30022 & 3621C4E

BMP020068/2004055V
(Sheet 1 of 2)



Pellerin Milnor Corporation
P. O. Box 400, Kenner, LA 70063-0400

Litho in U.S.A.

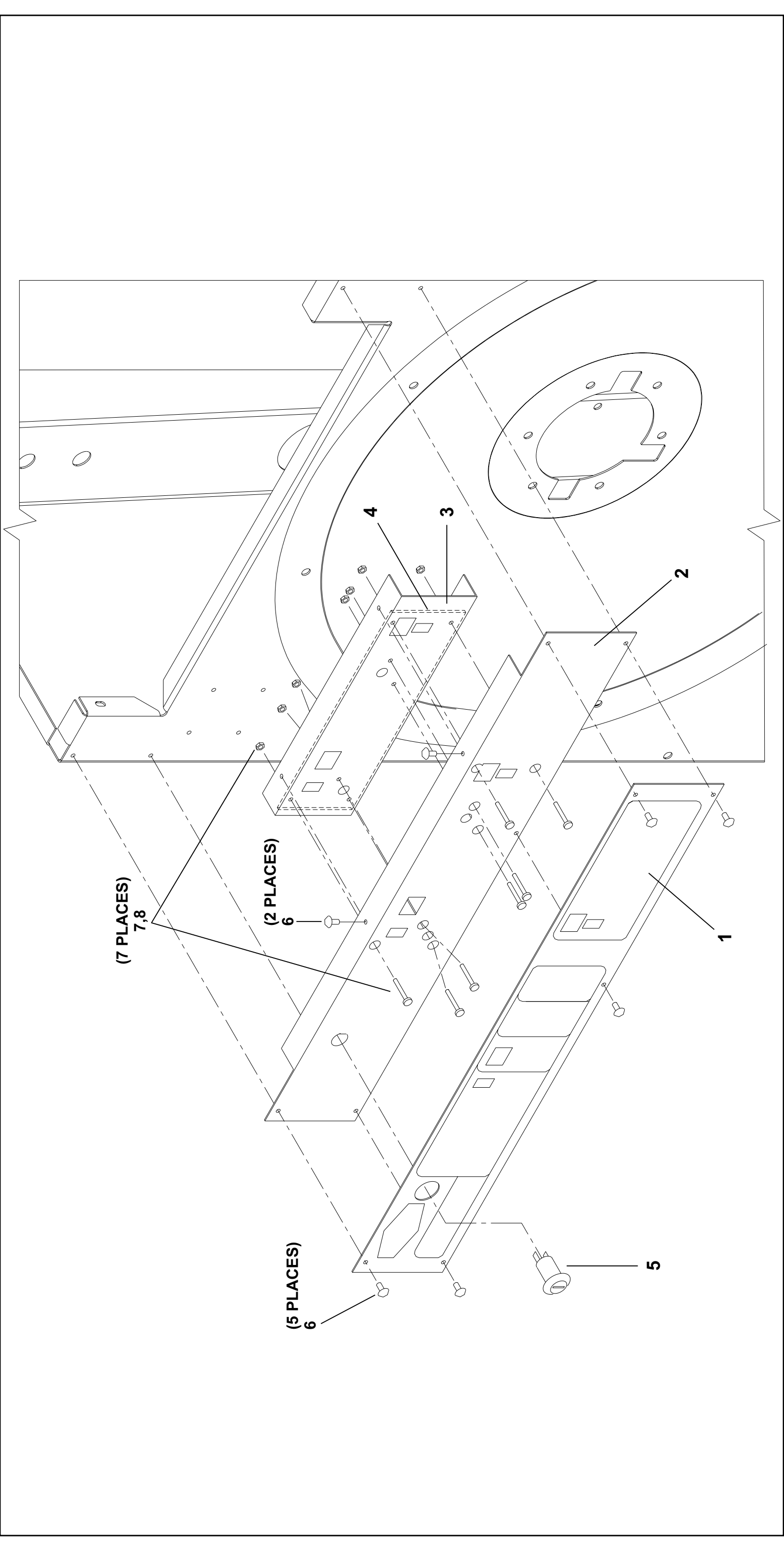



Pellerin Milnor Corporation
P. O. Box 400, Kenner, LA 70063-0400

Litho in U.S.A.

Parts List—Switch Panel Assembly

Find the correct assembly first, then find the needed components. The item letters (A, B, C, etc.) assigned to assemblies are referred to in the "Used In" column to identify which components belong to an assembly. The item numbers (1, 2, 3, etc.) assigned to components relate the parts list to the illustration.

Used In	Item	Part Number	Description	Comments
			-----ASSEMBLIES-----	
	A	ESP71CEA	SWPNL 3022C4E	
			-----COMPONENTS-----	
all	1	01 10705	GRAPHIC PANEL=C4E SW PNL	
all	2	03 CF529V	PANEL:SWPNL 3022C4E CONTROLS	
all	3	03 CF513V	BRKT:C4E BOARD MOUNTING	
all	4	08BTCSTAT	BD:C4E COIN STATUS->TEST	
all	5	09N127C	KEYSW SPST 7A120VAC SCREW TERM	
all	6	15P101B	TRDCUT-FPANHD8-32 X3/8	
all	7	15N069A	PANMACHSCR 6-32UNC X 1.500"LG	
all	8	15G073	HEXMACHSCRNUT 6-32UNC.NYLON	

Coin Acceptor and Vault
30015, 30022 & 3621C4E

BMP020061/2003276V
 (Sheet 1 of 2)



Pellerin Milnor Corporation
 P. O. Box 400, Kenner, LA 70063-0400

Litho in U.S.A.

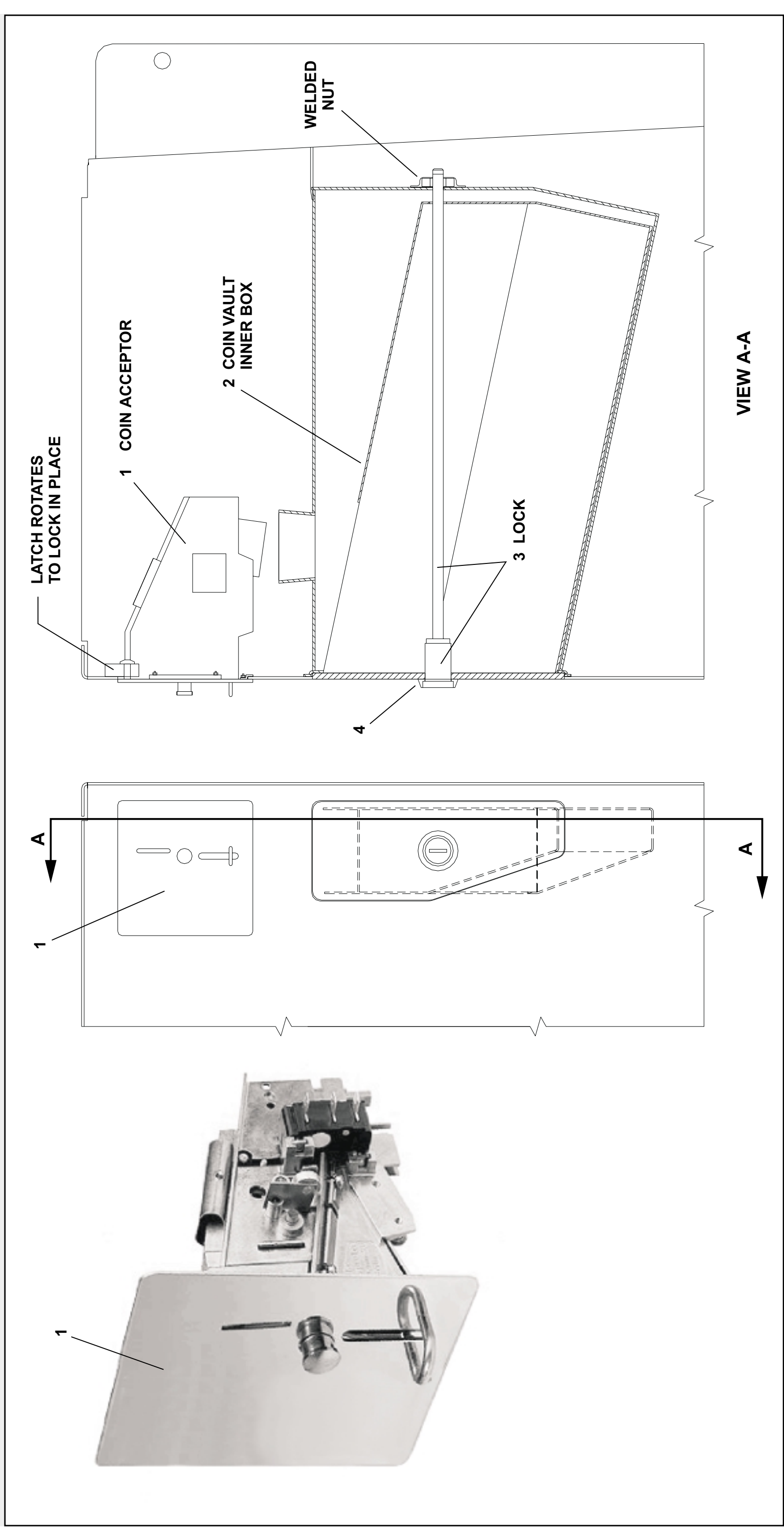



Pellerin Milnor Corporation
P. O. Box 400, Kenner, LA 70063-0400

Litho in U.S.A.

Parts List—Coin Acceptor and Vault

Find the correct assembly first, then find the needed components. The item letters (A, B, C, etc.) assigned to assemblies are referred to in the "Used In" column to identify which components belong to an assembly. The item numbers (1, 2, 3, etc.) assigned to components relate the parts list to the illustration.

Used In	Item	Part Number	Description	Comments
			-----ASSEMBLIES-----	
	A	A33 08500A	COIN VAULT 13.5X7 ASSY	
			-----COMPONENTS-----	
all	1	38C080	REJECTOR F77.1-W2004-I4	
all	2	W2 03690C	COIN VAULT INNER BOX WELD	
all	3	38C152A	LOCK+2KEY CONSEC NO.15+1/8"LG	
all	4	02 03426	WASHER-LOCK PROTECT-CHROME	

VIBRATION SAFETY SWITCH ADJUSTMENTS

B What the Vibration Safety Switch Does

The *vibration safety switch* pictured below is an important safety feature. If properly adjusted, the switch will momentarily actuate as a result of repeated machine movement caused by an out-of-balance condition. Table A below illustrates the effect of the *vibration safety switch* actuation.

Table A—Effect of Tripping Vibration Safety Switch

Machine Model	Function of Vibration Safety Switch
30015, 30020, and 30022	Disables high speed extract
All microprocessor-controlled washer-extractors not listed above, and all dye machines	De-energizes three-wire relay, effectively terminating machine operation

Adjustments

When the machine leaves Milnor[®], the actuator arm is tie-wrapped to prevent damage (except on 30015, 30020, and 30022 models). **This tie wrap must be removed after the machine is set into position but before the machine is operated.**

Adjustment of this switch from the factory setting is not recommended; however, it should be checked for proper functioning and adjusted if its proper setting is lost.

As shown at right in FIGURE 1, the unit consists of a *sensitive micro-switch* with an extended actuating arm supporting an eccentric weight. The weight may be adjusted by moving it up and down on the arm and by rotating it on the arm. In addition, the *micro-switch* itself may be tilted from side to side.

The sensitivity of the switch increases as the eccentricweight is raised on the actuating arm and decreases as the weight is lowered.

The unit should be adjusted so that the actuating arm will always reset by itself, this being accomplished by rotating either the switch or the weight to give just enough bias to cause the switch to reset. Check the adjustment by moving the arm to the left then slowly releasing it. Make sure the micro-switch clicks when the arm is **slowly** released, thus indicating

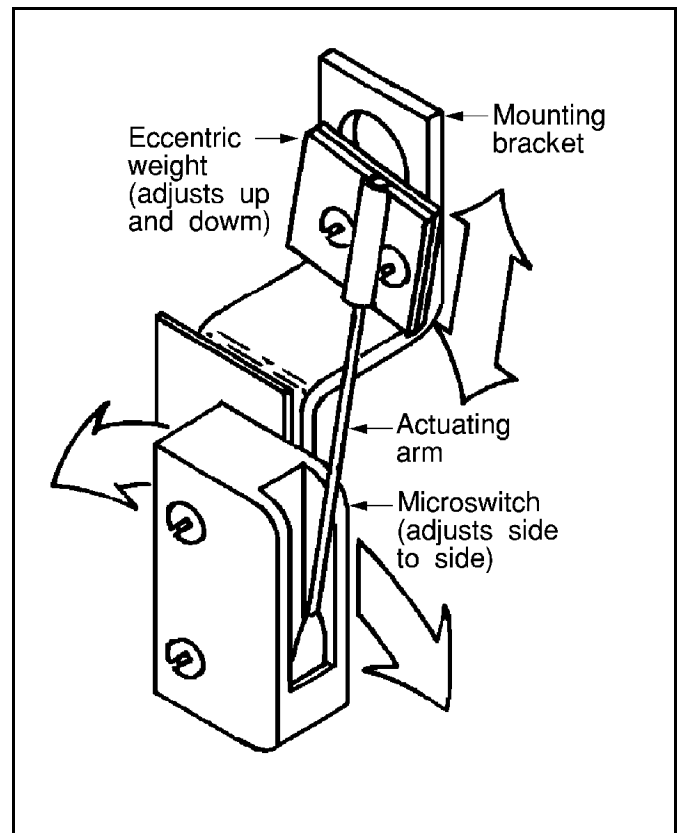

FIGURE 1 (MSSMA408BE)
Vibration Switch

that it has reset. In the released position the arm should rest **lightly** but definitely against the stop on the *micro-switch* case that prevents any further arm movement to the left.

For machines with rigid mounted shells, where the machine is bolted to a very substantial foundation, very little machine movement will occur for a given degree of out-of-balance. Under such conditions it may be better to adjust the switch to be very sensitive. With less substantial foundations (e.g., ones where the sub-soil is mushy or springy or otherwise not as desirable), considerably greater machine movement will occur for a given degree of out-of-balance, in which case a less sensitive *vibration switch* setting may be indicated.

Vibration Safety Switch

BMP910038/2006155B
(Sheet 1 of 1)



Pellerin Milnor Corporation
P. O. Box 400, Kenner, LA 70063-0400

Litho in U.S.A.

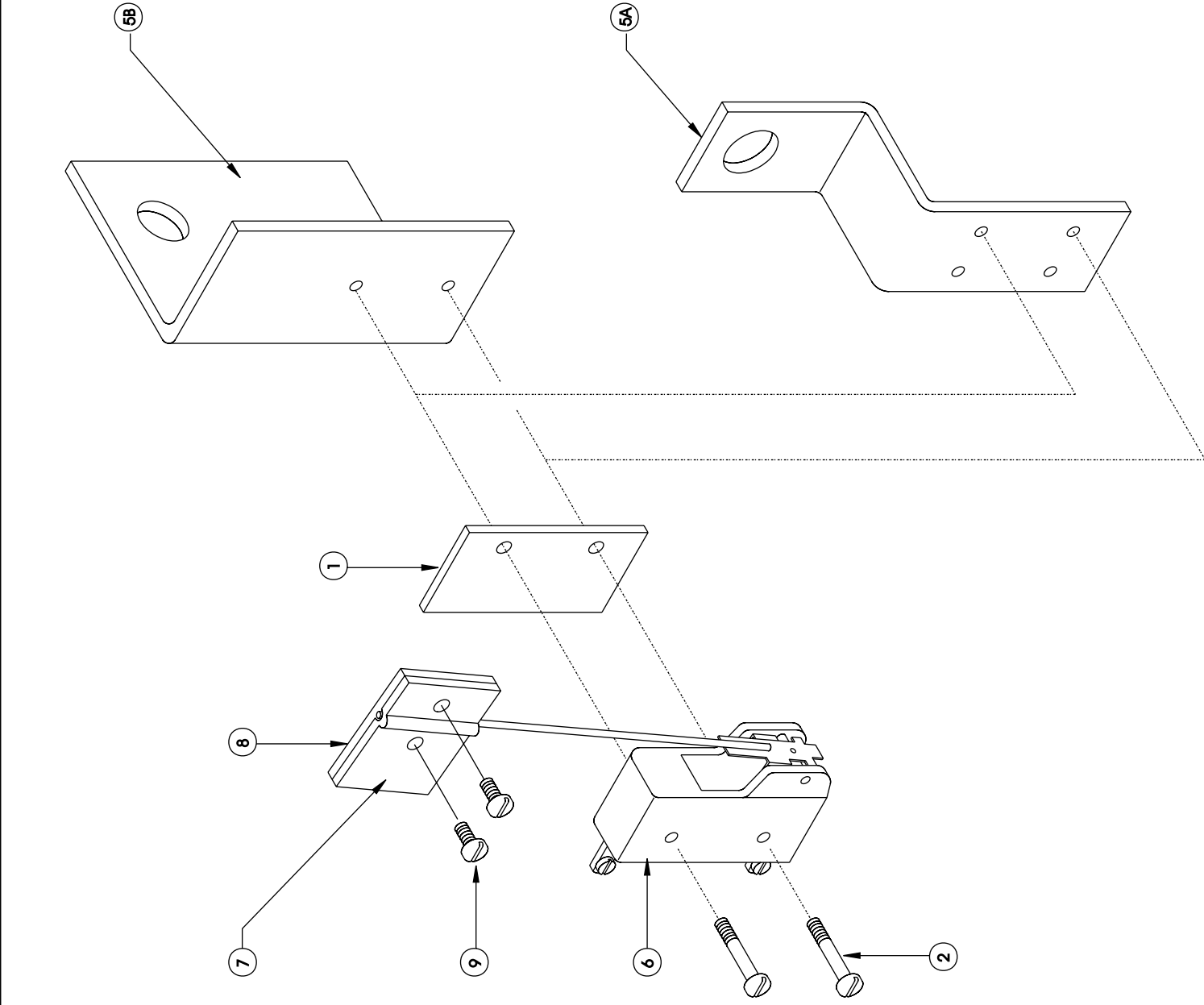

Parts List—Vibration Safety Switch
Find the correct assembly first, then find the needed components. The item letters (A, B, C, etc.) assigned to assemblies are referred to in the "Used In" column to identify which components belong to an assembly. The item numbers (1, 2, 3, etc.) assigned to components relate the parts list to the illustration.

Used In	Item	Part Number	Description	Comments
-----ASSEMBLIES-----				
A		SAE03 151	* ASSY-VIBRATION SWT=LG CONTR	(ALL MODELS EXCEPT BWP,CPE) 3015/22 V/T/G/F 3022F,362F, 4232F 3022X,3626X,4226X,4232X 4244, 6044,7244WP/SP CONTAINS 001,002, 005A-009
B		SAE03 151A	*ASSY-VIBRATION SWT=BALCOM	(MODELS 3621BWP,CPE ONLY) CONTAINS 001,002, 005B-009
-----COMPONENTS-----				
all	1	02 02038	PLATE INSULATING SMALL9NOV51	
all	2	15P008	TRDCUT PANHD 6-32X1 NIKSTL +WA	
A	5	02 15119	BRACKET=VIBSW CAD	
B	5	02 10264	BRACKET=SAFESW CAD	
all	6	09R020	SWITCH NC VIBR#WZ-2RW84429-P52	
all	7	03 01059	VIBSWITCH CLAMP CADSTL	
all	8	03 01058	VIBSWITCH WEIGHT-CADSTL	
all	9	15P101	TRDCUT-F PANHD 8-32X3/8 NIKSTL	

Section
Chemical Supply

6

Soap Chute Installation

3010 & 3015 G5E,G5X 3010 & 3015CGE
 30015V7J,T5J,T5E,C4A,C4T,C4E 30022V6J,T5J,T5E,C4A,C4T,C4E

BMP000040/2004055V
 (Sheet 1 of 1)



Pellerin Milnor Corporation
 P. O. Box 400, Kenner, LA 70063-0400

Litho in U.S.A.

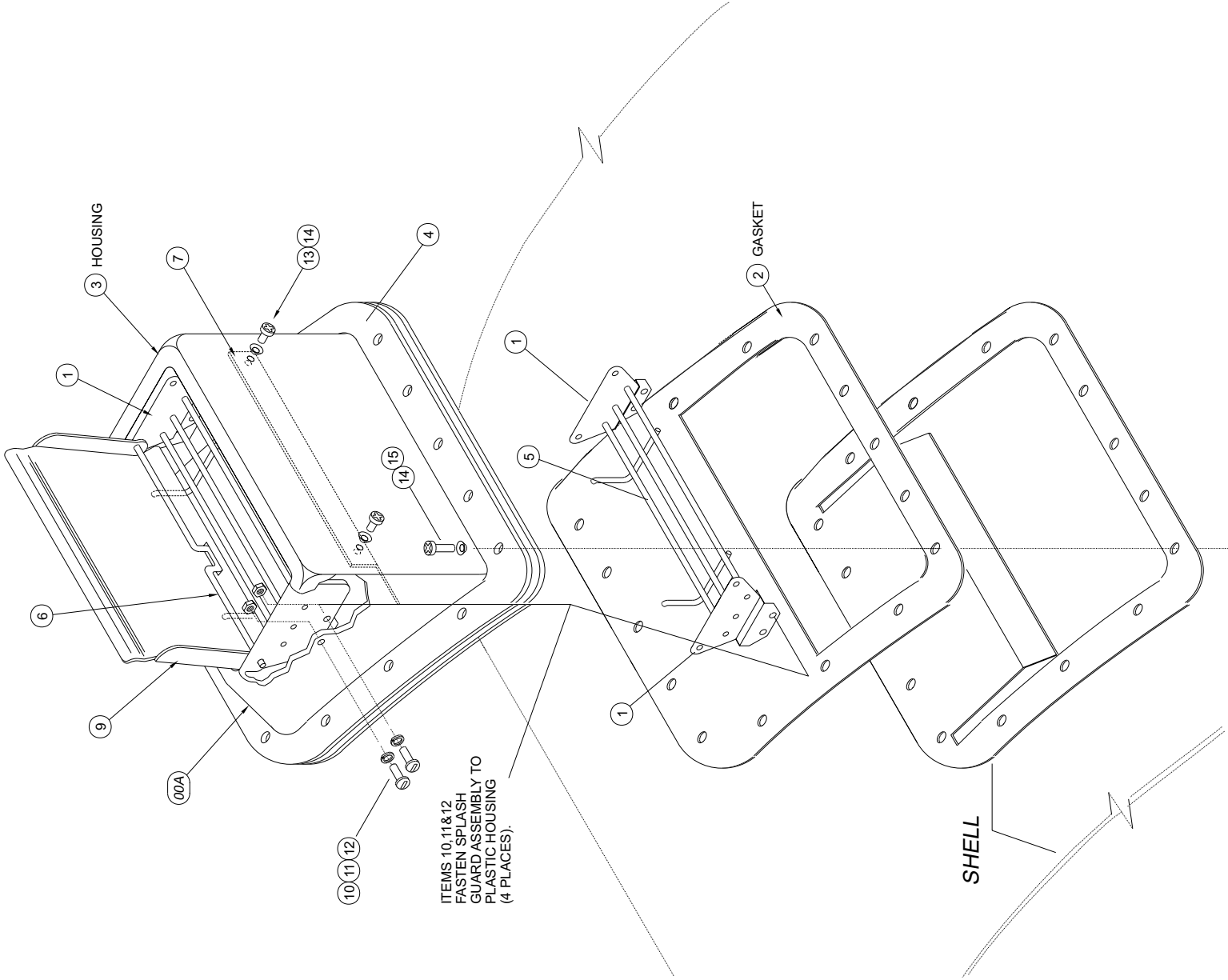

Parts List—Soap Chute Installation
 Find the correct assembly first, then find the needed components. The item letters (A, B, C, etc.) assigned to assemblies are referred to in the "Used In" column to identify which components belong to an assembly. The item numbers (1, 2, 3, etc.) assigned to components relate the parts list to the illustration.

Used In	Item	Part Number	Description	Comments
	A	SA-33-058M	94000Z ASSY=PLSTC SOAP INLET	
			ASSEMBLIES	
			COMPONENTS	
all	1	02 03130	BRACKET=PLASTIC SOAP INLET	
all	2	02 03304D	GASKET=SOAPCHUTE 1/8"EPDM BL	
all	3	02 03589I	PLASTIC SHELLSIDE SOAP INLET	
all	4	02 03589T	BACKING RING=PLSTC CHEM INLT	
all	5	02 03594	GUARD SOAP CHUTE=CWU	
all	6	02 03595	PIN SOAP CHUTE HINGE=CWU	
all	7	02 03630A	SPLASH GUARD= SOAP CHUTE	
All	9	02 03593	89432B LID-SOAPCHUTE CWE TY304 SS	
all	10	15N133	RDMACSCR 10-24UNCZA X5/8" SS18	
all	11	15U160	LOCKWASHER MEDIUM #10 SS18-8	
all	12	15G130	HEXMACHSCRNUT 10-24UNC2 SS18-8	
all	13	15P050	PHDCUT-F PANHD 10-32X3/4 SS410	
all	14	24G018N	ROLLED WASH.194ID NYLTITE 10W	
all	15	15P051	TRDFRM AB HOLTHD 10-16X3/4SS41	

Section
Water and Drain

7

Schematic Symbols Key

BMP920008/2000302V
(Sheet 1 of 1)



Pellerin Milnor Corporation
P. O. Box 400, Kenner, LA 70063-0400

Litho in U.S.A.

ISOMETRIC SYMBOLS

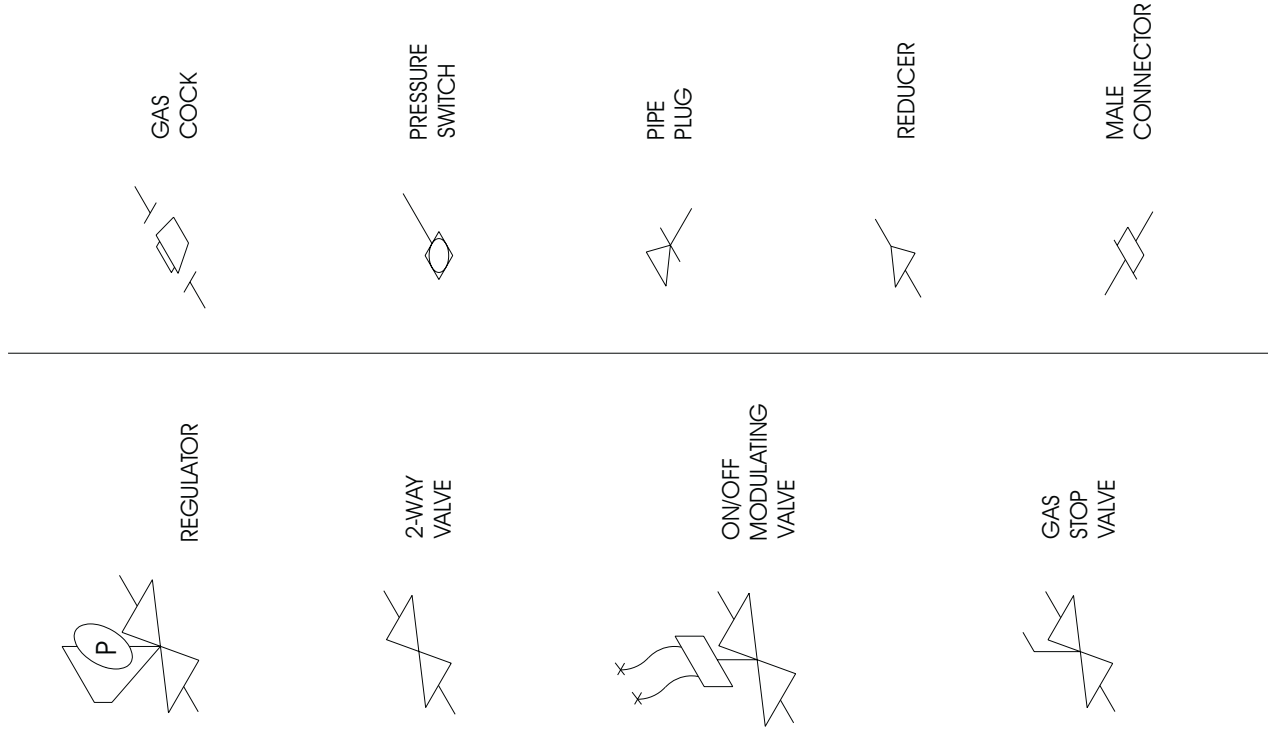

STANDARD SYMBOLS

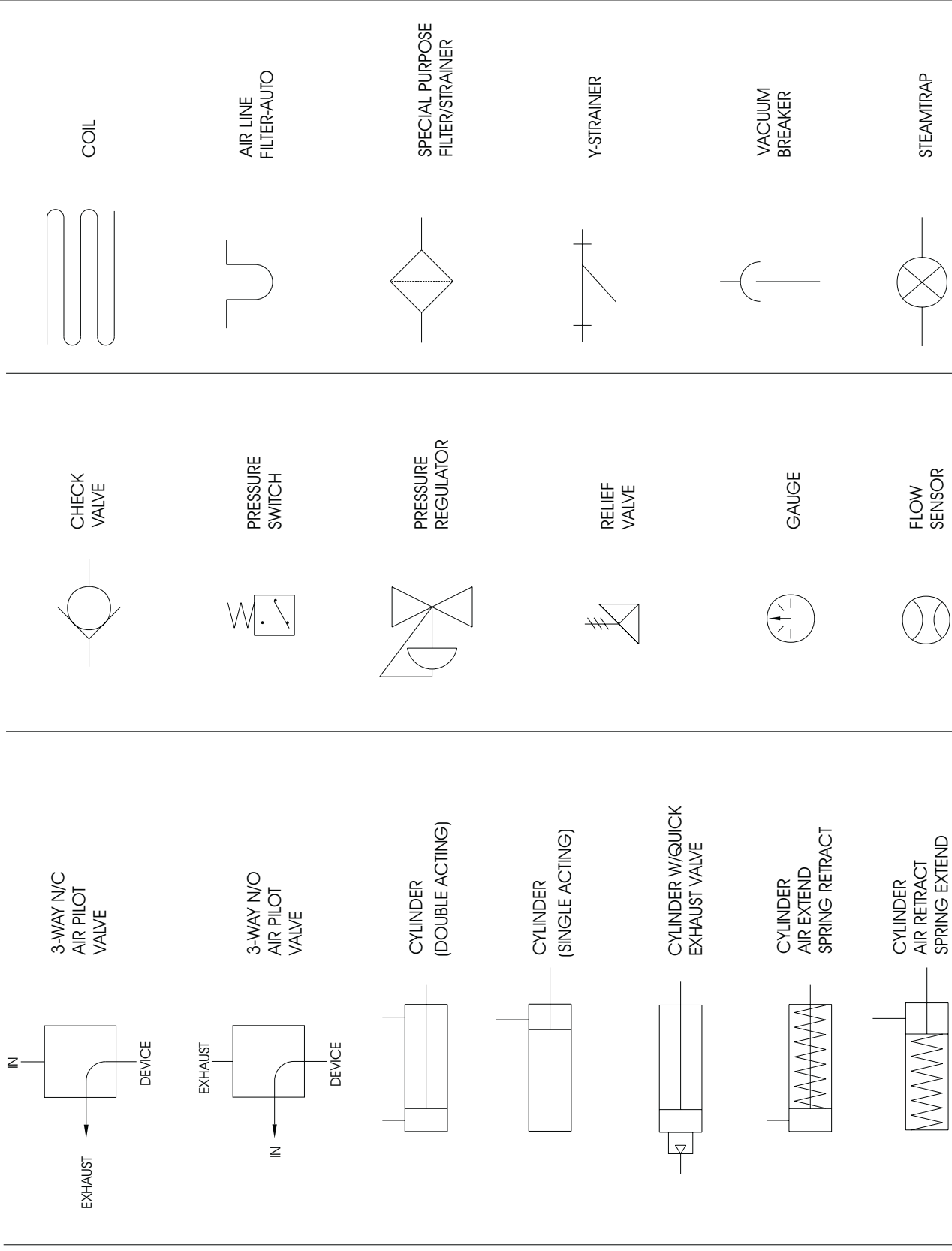

Water Schematic 30015 & 30022C4E

BMP020062/2002446V
(Sheet 1 of 1)



Pellerin Milnor Corporation
P. O. Box 400, Kenner, LA 70063-0400

Litho in U.S.A.

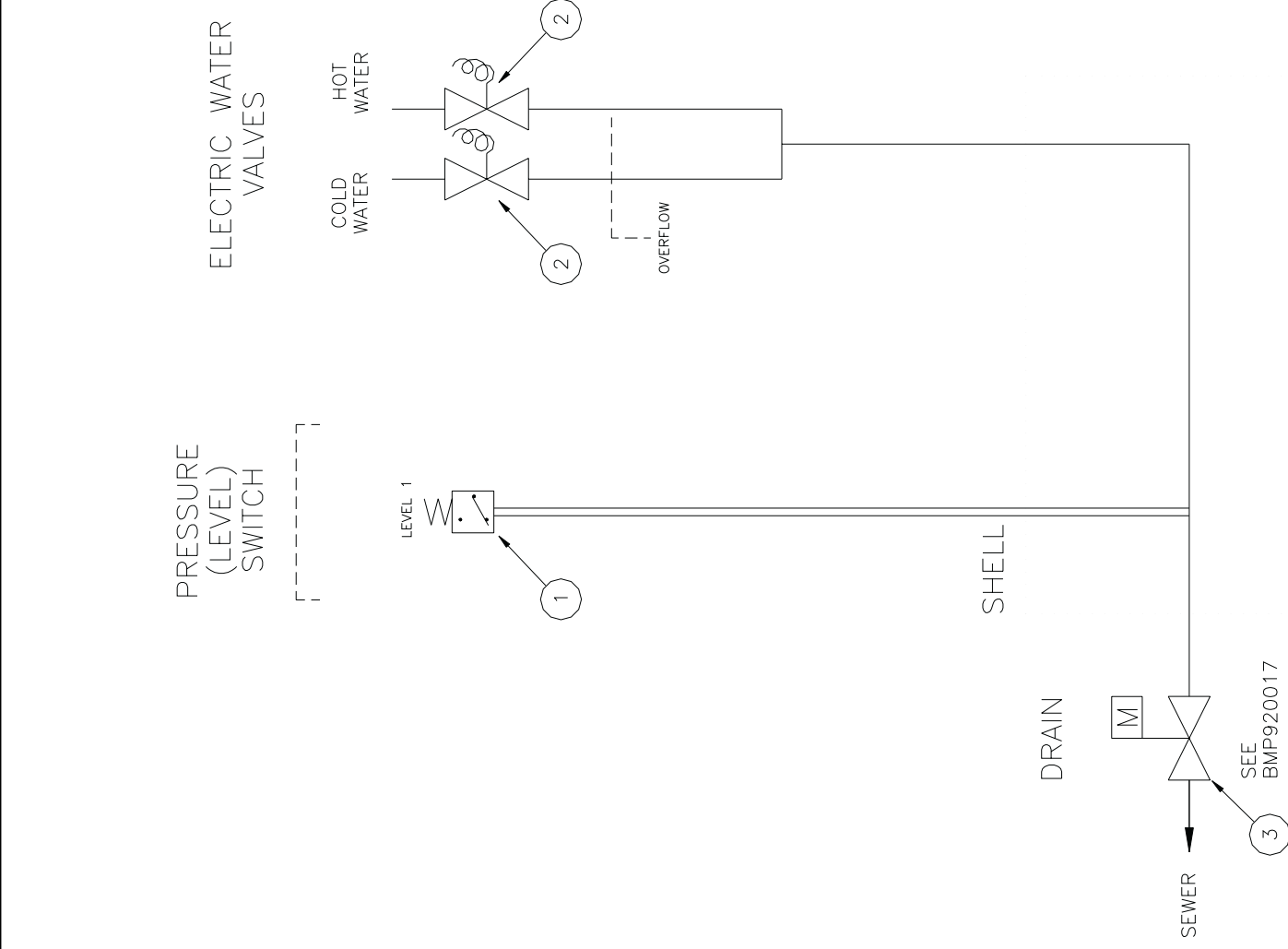

Parts List—Water Schematic
Find the correct assembly first, then find the needed components. The item letters (A, B, C, etc.) assigned to assemblies are referred to in the "Used In" column to identify which components belong to an assembly. The item numbers (1, 2, 3, etc.) assigned to components relate the parts list to the illustration.

Used In	Item	Part Number	Description	Comments
			-----ASSEMBLIES-----	
	A	SA 33 058S	3015/22 COIN H2O VALVE ASSY	
	B	AD 33 011U	FILL TUBE & DRN ASSY 240V COIN	
			-----COMPONENTS-----	
all	1	09N086A	PRESS SWITCH EATON #738-761	
all	2	96P053C71	3/4" INLET 3/4" HOSEOUT 220V	
all	3	96D350A71	DRINVAL 3"N/O MTRDR240V 50/60C	

Water Inlet
30015& 30022 C4E



Pellerin Milnor Corporation
 P. O. Box 400, Kenner, LA 70063-0400

Litho in U.S.A.

BMP020056/2003215V
 (Sheet 1 of 2)

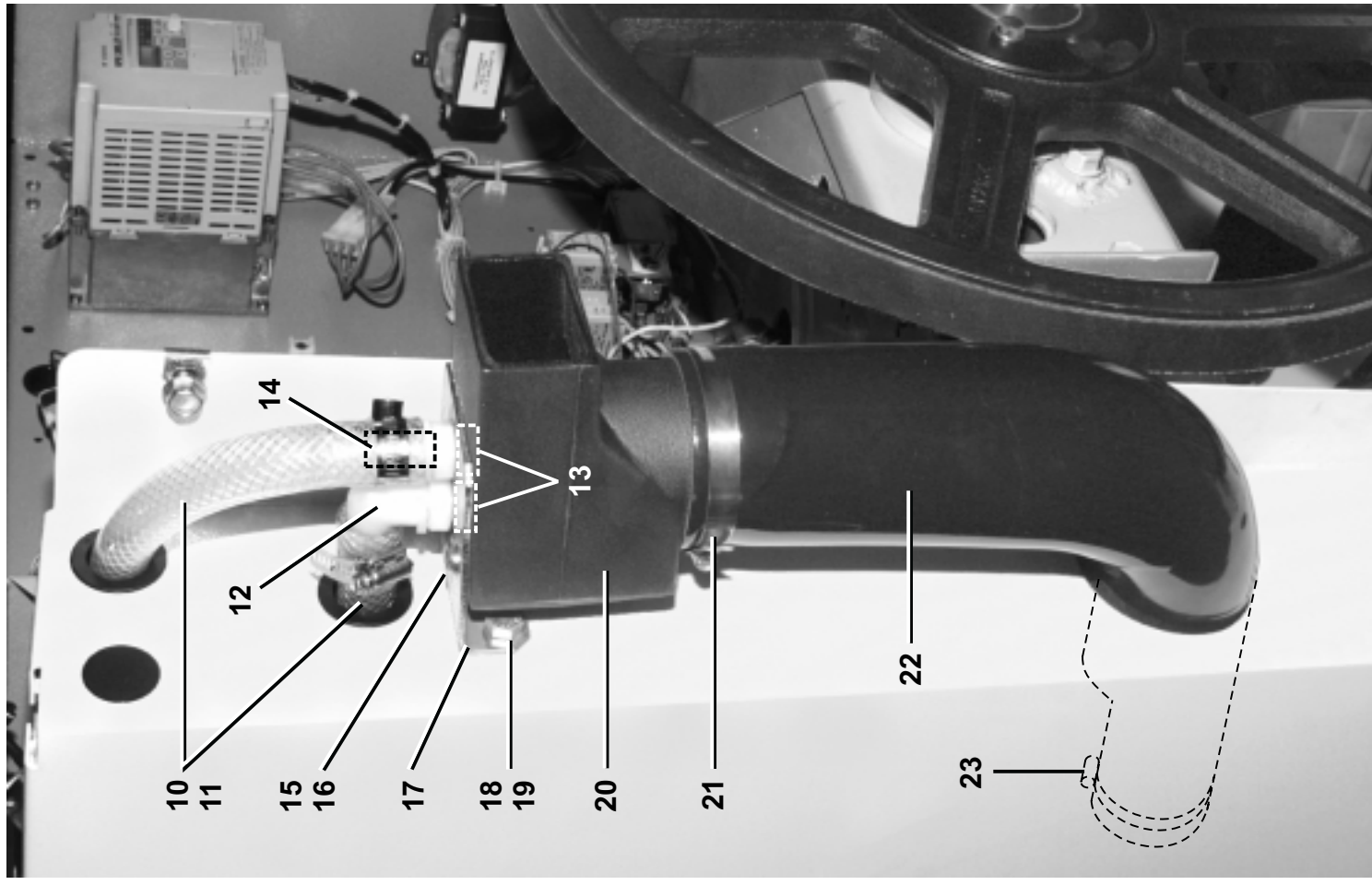
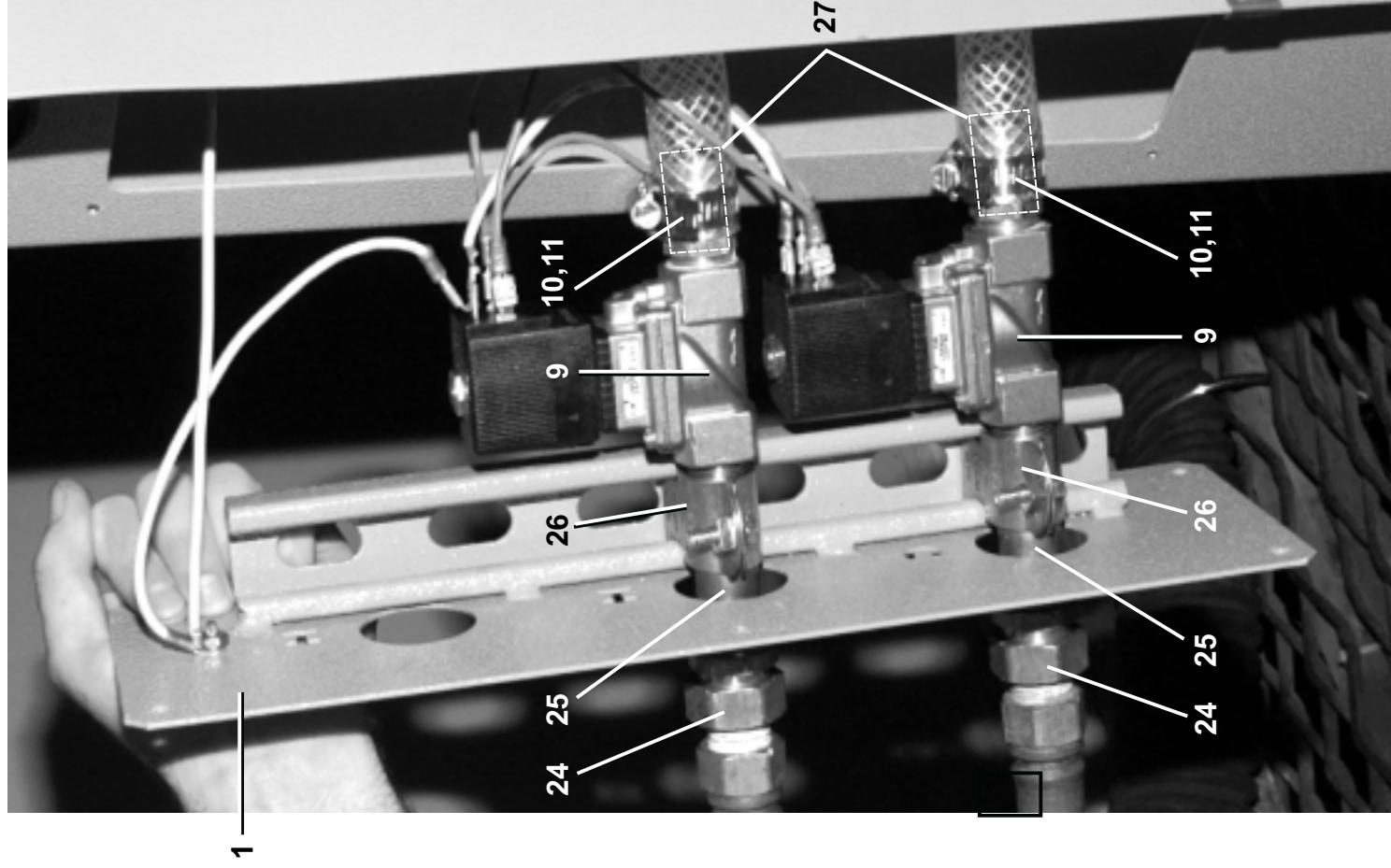
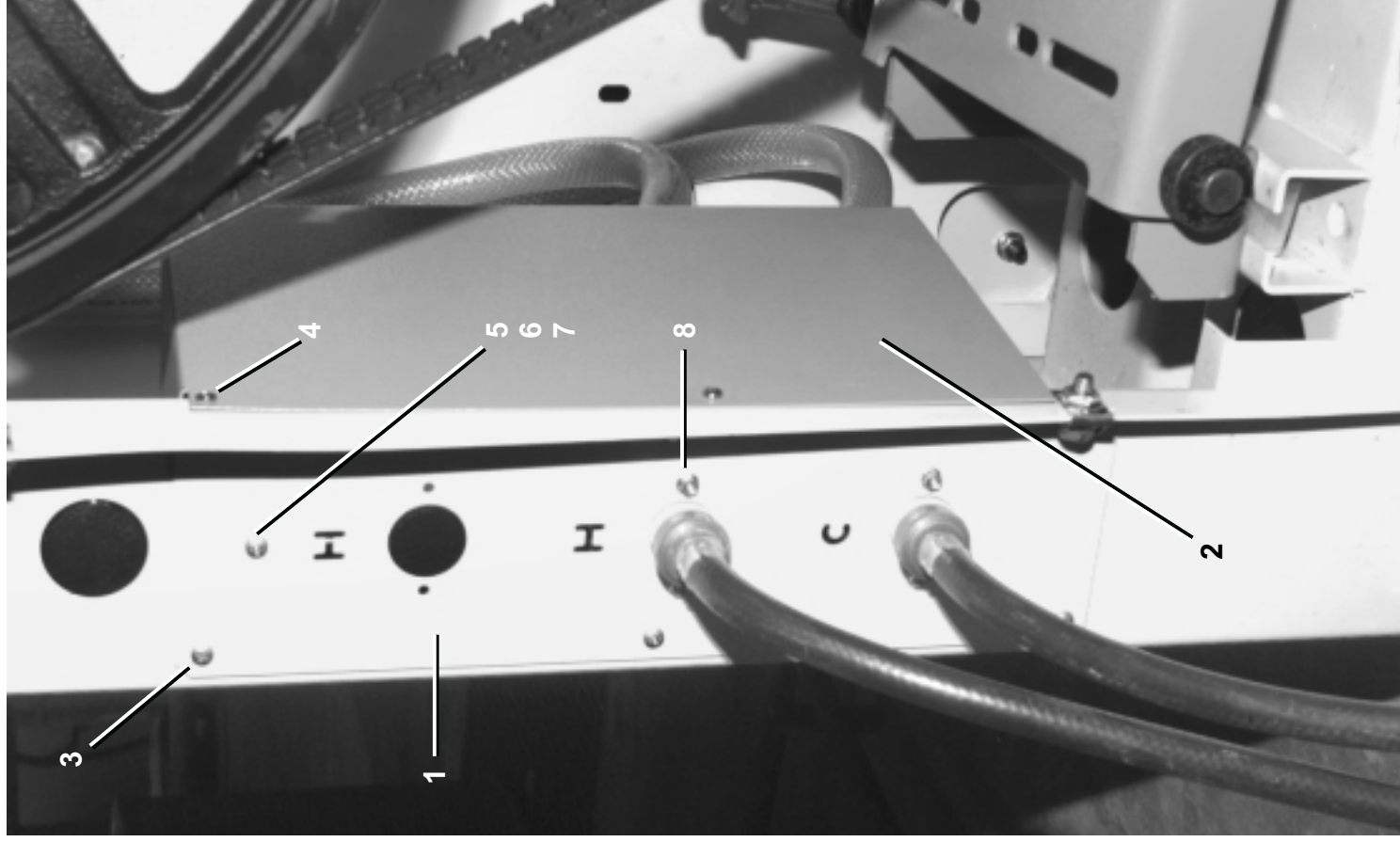



Pellerin Milnor Corporation
P. O. Box 400, Kenner, LA 70063-0400

Litho in U.S.A.

Parts List, cont.—Water Inlet

Used In	Item	Part Number	Description	Comments
-----ASSEMBLIES-----				
	A	GWV30001	INST=COIN H2O+PERSTALTIC INLET	
	B	AWV30001	PERSITALIC/H2O INLET BOX ASSY	
	C	SA 33 058U	3015/22 COIN BRSS H2O VLVE ASY	
-----COMPONENTS-----				
all	1	W2 03588S	3015/22 BRASS H2O MNT WLMT	
all	2	02 03588N	WATER VALVE COVER	
all	3	15P010	PHILPAN TRDCUTSCRTP10-24X1/2S	
all	4	15P101	TRDCUT-F PANHD 8-32X3/8 NIKSTL	
all	5	15N130	RDMACHSCR 10-24UNC2A X 1/2 SS1	
all	6	15U154	LOKVAS EXTTOOTH #10 (US STD) ZI	
all	7	15G130	HEXMACHSCRNUT 10-24UNC2 SS18-8	
all	8	15N004	FLGHDMACHSCR M4X.7X 9MM ZINC	
all	9	96P057A71	1/2"NPT X 1/2"ORIFICE 240V 5/6	
all	10	60E008A	TUBINGNYLREINF.75"IDX1.025"OD	
all	11	27A044S	HOSECLAMP 11/16-1.25SSCR#64012	
all	12	51E513EBN	3/4" 90DEG. ELBOW W/NUT	
all	13	51E513NU	NUT 11/16 THRD.#64138 US PLAST	
all	14	51E513N	HOSEADPT3/4"HX11/16 W/NUT=NYL.	
all	15	15K031	BUTSOKCAPSCR 1/4-20X1/2 SS18-8	
all	16	15U181	LOCKWASHER MEDIUM 1/4 SS18-8	
all	17	02 03588R	3015/22 COIN PERST BOX BRKT	
all	18	15K085	HEXCAPSCR 3/8-16UNC2AX3/4 GR5	
all	19	15G198	HXFLGNUT 3/8-16 ZINC	
all	20	02 03588P	PERISTALTIC/WATER INLET COIN	
all	21	27A082S	HOSECLAMP 2+9/16-3.5SS305SCR	
all	22	02 03588B	PARISTALTIC/WATER INLET HOSE	
all	23	27A074S	HOSECLAMP 2+1/16-3"SSSCR#64040	
all	24	51E510	HOSESTEM BRASS 1/2MPX3/4HOSEID	
all	25	5N0K03KB42	NPT NIP 1/2X3.5 TBE BRASS STD	
all	26	27A0050	CLP-RGDSTL COND #PS1100-1/2	
all	27	51E513B	3/4"MHX1/2"FP PARKER#80GH-12-8	

Level Switches 30015 & 30022C4E

BMP020060/2002446V
(Sheet 1 of 1)



Pellerin Milnor Corporation
P. O. Box 400, Kenner, LA 70063-0400

Litho in U.S.A.

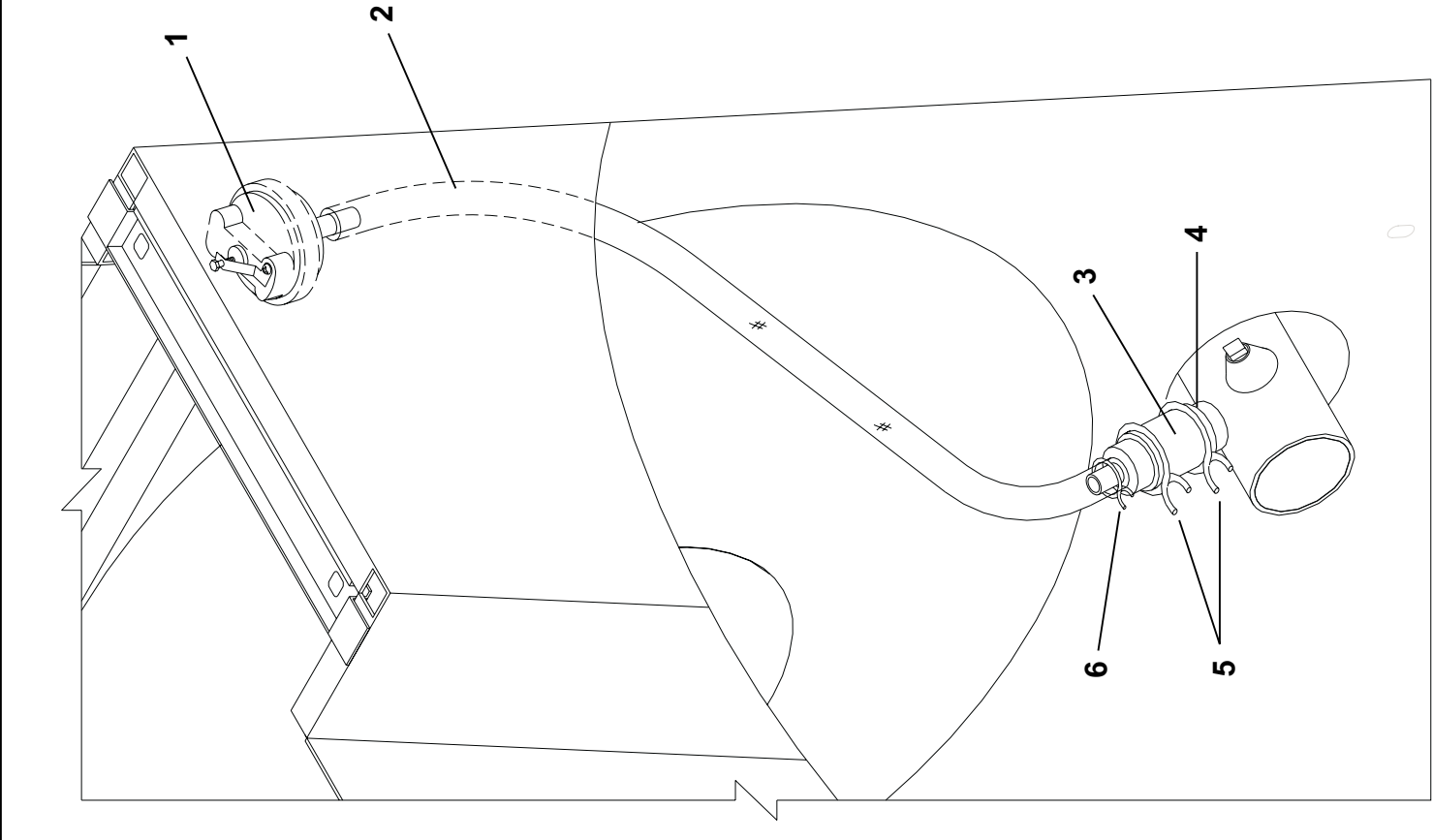

Parts List—Level Switches
Find the correct assembly first, then find the needed components. The item letters (A, B, C, etc.) assigned to assemblies are referred to in the "Used In" column to identify which components belong to an assembly. The item numbers (1, 2, 3, etc.) assigned to components relate the parts list to the illustration.

Used In	Item	Part Number	Description	Comments
	A	GPS30001	ASSEMBLIES	
	B	A33 12000J	PRESS SWITCH/CHAMBER INSTALL PRES TUBE "T" ASSY MXJ	
			COMPONENTS	
all	1	09N086A	PRESS SWITCH EATON #738-761	
all	2	60E005P	PVC TUBING 1/2"ID X 5/8"OD	
all	3	02 03332C	AIRCHAMBER=PRESSWITH-CWU	
all	4	51AB1EN1A	INSERT REDUCER PVC 1+1/4"X 1"	
all	5	27A052	HOSECLAMP 1.5"DIA.SPRING#R24HC	
all	6	27A044A	HOSECLAMP.687"ID ROTOR#HC11STR	

Drain Sump Installation
3010 G5E,G5X,CGE; 3015G5E,G5X,CGE
30015, 30022Vxx, Txx, C4A, C4T, C4E; 30015, 30020, 30022Qxx

BMP920014/2004055V
 (Sheet 1 of 1)



Pellerin Milnor Corporation
 P. O. Box 400, Kenner, LA 70063-0400

Litho in U.S.A.

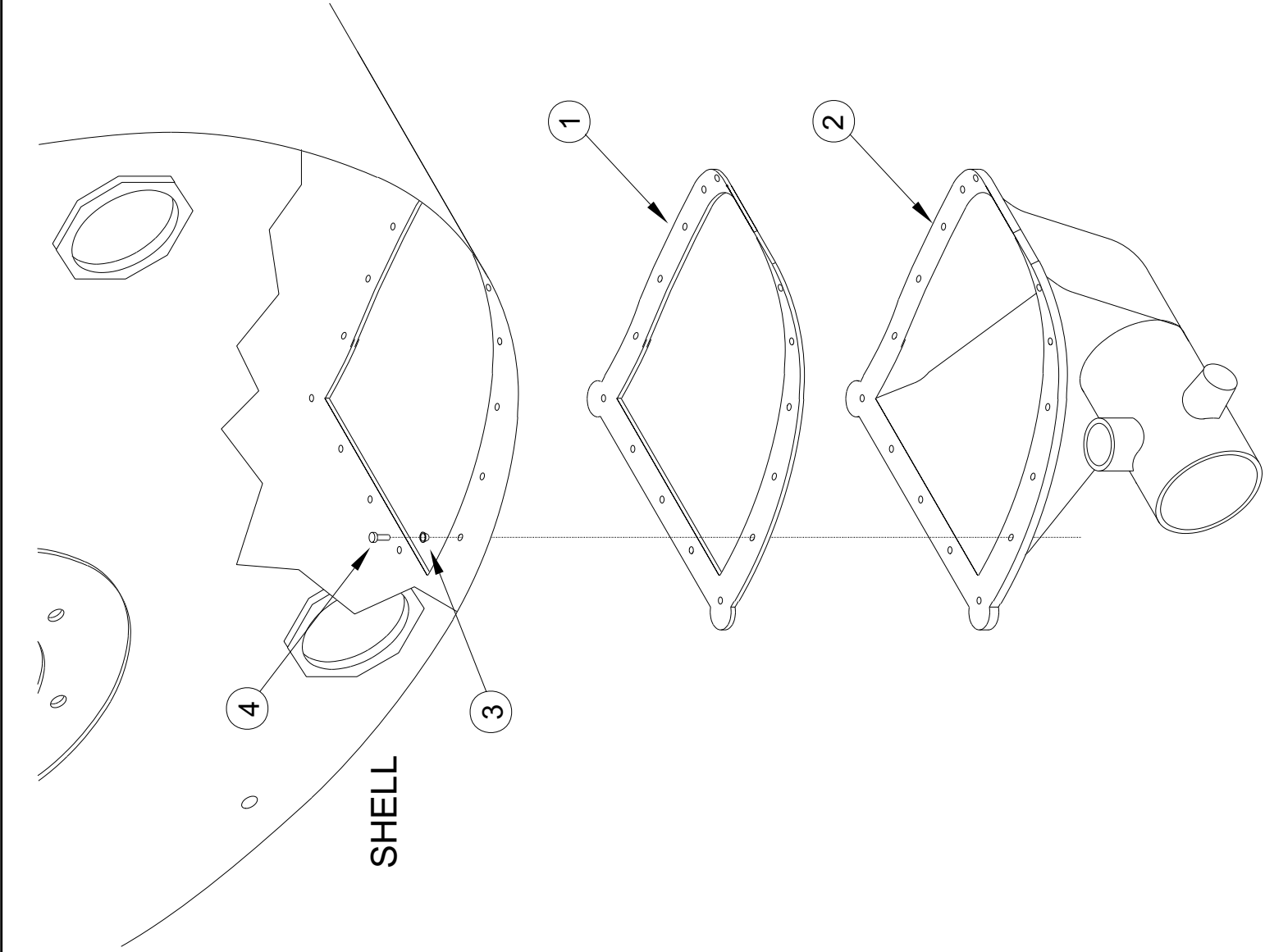

Parts List—Drain Sump Installation

Find the correct assembly first, then find the needed components. The item letters (A, B, C, etc.) assigned to assemblies are referred to in the "Used In" column to identify which components belong to an assembly. The item numbers (1, 2, 3, etc.) assigned to components relate the parts list to the illustration.

Used In	Item	Part Number	Description	Comments
			-----COMPONENTS-----	
all	1	02 03366A	DRAIN SUMP GASKET 1/8"EPDM	
all	2	02 03332A	BODY=SUMP-1608 GLASTIC	
all	3	24G018N	ROLLED WASH:194ID NYLTITE 10W	
all	4	15P050	PHDCUT-F PANHD 10-32X3/4 SS410	

Drain Valve Installation
3010 & 3015 G5E, G5X, CGE
30015 & 30022 C4E

BMP020057/2004055V
(Sheet 1 of 2)



Pellerin Milnor Corporation
P. O. Box 400, Kenner, LA 70063-0400

Litho in U.S.A.

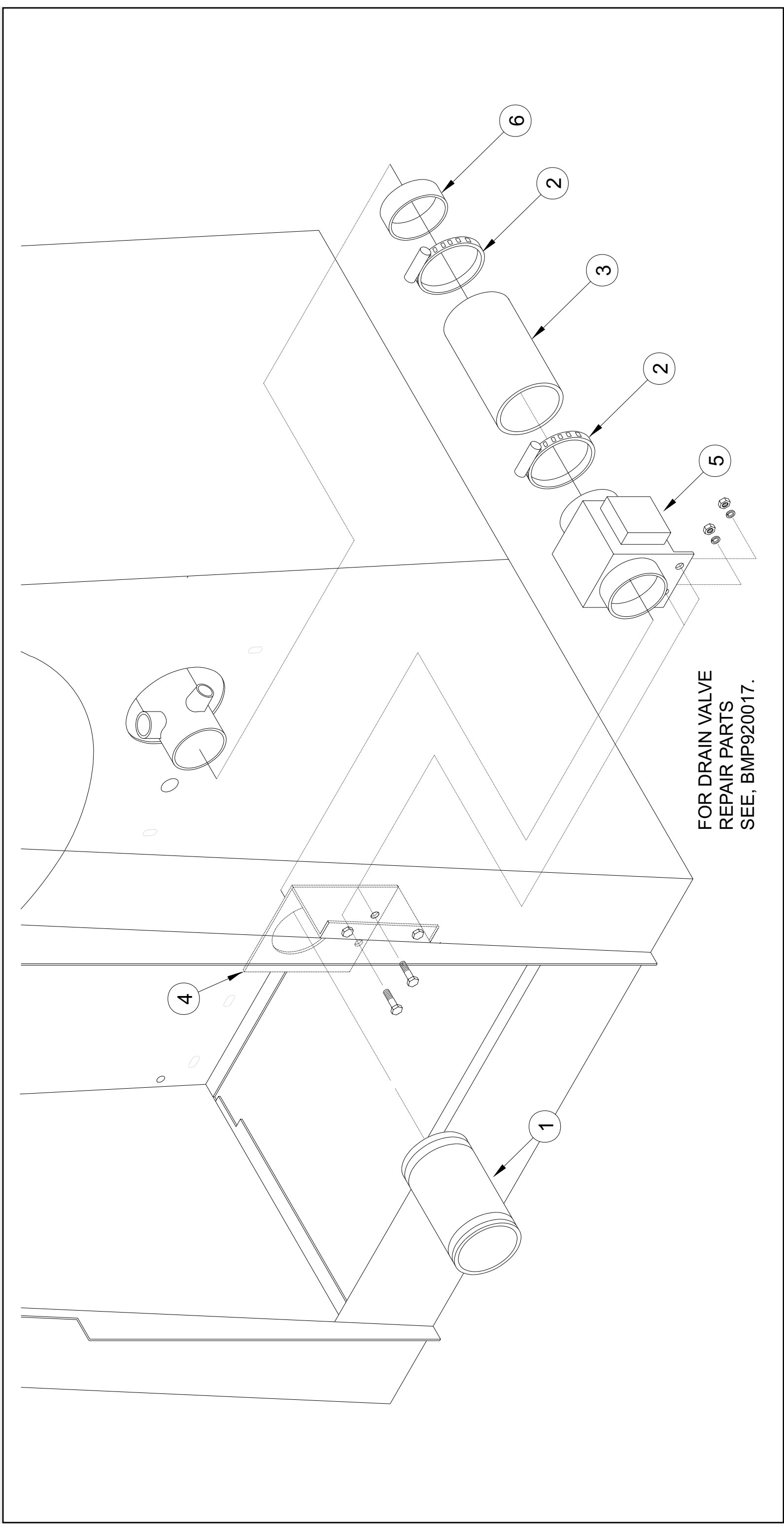

FOR DRAIN VALVE
REPAIR PARTS
SEE, BMP920017.



Pellerin Milnor Corporation
P. O. Box 400, Kenner, LA 70063-0400

Litho in U.S.A.

Parts List—Drain Valve Installation

Find the correct assembly first, then find the needed components. The item letters (A, B, C, etc.) assigned to assemblies are referred to in the "Used In" column to identify which components belong to an assembly. The item numbers (1, 2, 3, etc.) assigned to components relate the parts list to the illustration.

Used In	Item	Part Number	Description	Comments
-----ASSEMBLIES-----				
	A	GDV30001	30" DRAINVALVE INSTALL	3015,3022C4E
	B	GDV30003	3010 SINGLE DRAIN TO REAR INST	3010,3015G5E,G5X,CGE
-----COMPONENTS-----				
all	1	60B075	DFW56-33PMSP RUBB CONN.	
all	2	27A082	HOSECLAMP 2.5625-3.5CADSC#HS48	
all	3	60E303A07A	HOSE=3"ID X 7" LG.	
A	4	02 03412E	3015/22 DRAIN VALVE BRKT	
B	4	02 03412J	3010 DRAIN VALVE BRKT	
all	5	96D350A71	DRINVAL 3"N/O MTRDR240V 50/60C	
all	6	02 03412S	SLEEVE=DUMPVALVE HOSE	

3" Electric Drain Valve

BMP920017/2006214B
(Sheet 1 of 2)



Pellerin Milnor Corporation
P. O. Box 400, Kenner, LA 70063-0400

Litho in U.S.A.

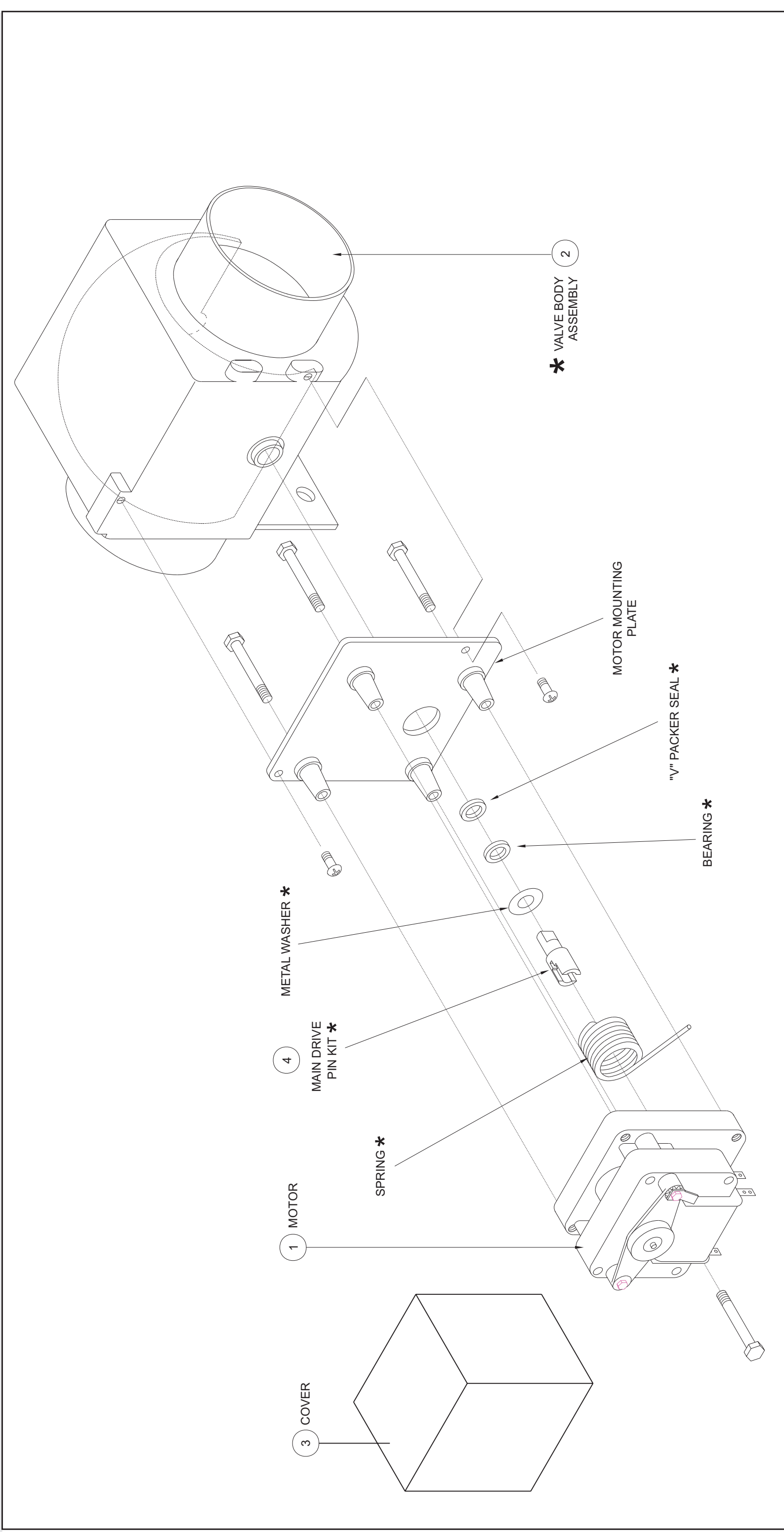



Pellerin Milnor Corporation
P. O. Box 400, Kenner, LA 70063-0400

Litho in U.S.A.

Parts List—3” Electric Drain Valve

Find the correct assembly first, then find the needed components. The item letters (A, B, C, etc.) assigned to assemblies are referred to in the "Used In" column to identify which components belong to an assembly. The item numbers (1, 2, 3, etc.) assigned to components relate the parts list to the illustration.

Used In	Item	Part Number	Description	Comments
-----ASSEMBLIES-----				
	A	96D350A37	DRINVAL 3"N/O MTRDR120V 50/60C	
	B	96D350A71	DRINVAL 3"N/O MTRDR240V 50/60C	
	C	96D350B71	DRINVAL 3"N/C MTRDR240V 50/60	
-----COMPONENTS-----				
A	1	96D35MTR37	120V 50/60CMTR FOR 3"DRAINVAL	
B	1	96D35MTR71	240V 50/60CMTR FOR 3"DRAINVAL	
all	2	96D35B0D	BODY & BALL FOR 3" DRAIN VALVE	
all	3	96D35C0V	MTRCOVER 2-PCFOR 3"DRAINVAL	
A,B	4	96D35PIN	DRIVE PIN KIT FOR 3" DRAIN VAL	